

Rosemount 1151 Pressure Transmitter

This product is in the process of being discontinued. Limited supply available. Please consult a local Emerson Process Management contact for details.



Rosemount 1151 Pressure Transmitter

NOTICE

Read this manual before working with the product. For personal and system safety, and for optimum product performance, make sure you thoroughly understand the contents before installing, using, or maintaining this product.

For technical assistance, contacts are listed below:

Customer Central

Technical support, quoting, and order-related questions.

United States - 1-800-999-9307 (7:00 am to 7:00 pm CST)

Asia Pacific- 65 777 8211

Europe/ Middle East/ Africa - 49 (8153) 9390

North American Response Center

Equipment service needs.

1-800-654-7768 (24 hours—includes Canada)

Outside of these areas, contact your local Emerson Process Management representative.

⚠ CAUTION

The products described in this document are NOT designed for nuclear-qualified applications.

Using non-nuclear qualified products in applications that require nuclear-qualified hardware or products may cause inaccurate readings.

For information on Rosemount nuclear-qualified products, contact your local Emerson Process Management Sales Representative.

Table of Contents

SECTION 1	Using This Manual	1-1
Introduction	Models Covered	1-2
SECTION 2	Overview	2-1
Installation	Safety Messages	2-2
	Warnings	2-2
	General Considerations	2-4
	Transmitter Access Requirements	2-4
	Mechanical Considerations	2-5
	Mounting Considerations	2-8
	Mounting Requirements (for Steam, Liquid, Gas)	2-8
	Process Connections	2-10
	Mounting Brackets	2-11
	Electrical Considerations	2-13
	Power Supply	2-13
	Conduit Installation	2-13
	Wiring	2-14
	Grounding	2-15
	Hazardous Locations Certifications	2-17
	Environmental Requirements	2-17
	Liquid Level Measurement	2-17
	Closed Vessels	2-17
	Installation Options	2-21
	Mounting Brackets	2-21
	Analog Displays	2-21
	LCD Displays	2-21
	Terminal Blocks	2-24
SECTION 3	Overview	3-1
Configuration	Safety Messages	3-1
(Smart Only)	Warnings	3-1
	Commissioning the Transmitter on the Bench	3-1
	Setting Hardware Switches	3-1
	Commissioning with a HART-Based Communicator	3-3
	Wiring Diagrams	3-3
	Bench Hook-up	3-3
	Field Hook-up	3-4
	Hart Communicator	3-5
	Testing the Equipment and the Loop	3-6
	Common Functions	3-7
	Configure the Analog Output Parameters	3-7
	Reranging	3-7
	Advanced Functions	3-12
	Multidrop Communication	3-13

Rosemount 1151

SECTION 4 Operation and Maintenance

Overview	4-1
Safety Messages	4-1
Warnings	4-1
Smart Calibration	4-2
Calibration Overview	4-2
Calibrate the Sensor	4-4
Digital to Analog Converter Trim	4-8
Analog Calibration	4-9
Calibration Overview	4-9
Quick Calibration Procedure (for E and G Electronics)	4-9
Quick Calibration Procedure (For L and M Electronics)	4-9
Data Flow with Calibration Options	4-11
Span Adjustment Range	4-11
Zero Adjustment Range	4-11
Zero and Span Adjustment	4-13
Elevated or Suppressed Zeros	4-14
Linearity Adjustment	4-15
Damping Adjustment	4-15
Static Pressure Span Correction Factor	4-16

SECTION 5 Troubleshooting

Overview	5-1
Safety Messages	5-1
Warnings	5-1
Smart Troubleshooting	5-3
Disassembly Procedure	5-5
Reassembly Procedure	5-7
Optional Plug-in Meters	5-9
Sensor Module Checkout	5-9
Analog Troubleshooting	5-10
Hardware Diagnostics	5-10
Transmitter Disassembly	5-12
Process Sensor Body Removal	5-13
Reassembly Procedure	5-15
Backup Ring and O-ring Installation	5-16
Optional Plug-in Meters	5-18

SECTION 6 Retrofitting the Rosemount 1151 Transmitter

Overview	6-1
Safety Messages	6-1
Warnings	6-1
Retrofitting Overview	6-2
Removing the Analog Electronics Assembly	6-2
Installing the Smart Retrofit Kit	6-10
Characterization	6-12
Before Characterizing the Transmitter	6-13
Characterizing with a HART Communicator	6-14

APPENDIX A	Performance Specifications	A-1
Reference Information	Functional Specifications	A-3
	Physical Specifications	A-8
	Electrical Connections	A-8
	Process Connections	A-8
	1151 Process Wetted Parts	A-8
	1151LT Process Wetted Parts	A-9
	Non-wetted Materials	A-9
	Dimensional Drawings	A-11
	Ordering Information	A-16
	1151 Parts List.	A-22
	1151LT Parts List.	A-30
	Display Specifications	A-34
APPENDIX B	Approved Manufacturing Locations	B-1
Product Certifications	European Directive Information	B-1
	Hazardous Locations Certifications	B-2
	North American Certifications.	B-2
	European Certifications	B-2
	Australian Certifications	B-3
	Combination Certifications	B-4
	Approval Drawings.	B-4
APPENDIX C	Glossary.	C-1 to C-2
Index	Index	Index-1 to Index-2

Section 1 Introduction

Using This Manual	page 1-1
Models Covered	page 1-2

USING THIS MANUAL

This manual provides information on installation, operation, and maintenance of Rosemount 1151 Pressure Transmitters. This manual is organized into the following sections:

Section 2—Installation

This section provides mechanical and electrical installation instructions.

Section 3—Configuration

This section contains commissioning, output check, basic setup, LCD Display configuration, detailed setup, diagnostic and services, and advanced functions.

Section 4—Operation and Maintenance

This section contains calibration and trim procedures.

Section 5—Troubleshooting

This section provides troubleshooting techniques for the most common operating problems.

Section 6—Retrofitting the Rosemount 1151 Transmitter

This section describes how the Rosemount Smart Retrofit Kit can be used to retrofit a Rosemount 1151AP, DP, GP, HP, or LT transmitter with 4-20 mA linear or square root output.

Appendix A—Reference Information

This appendix supplies reference and specification data, as well as ordering information and spare parts tables.

Appendix B—Product Certifications

This appendix contains European directive information, Hazardous Location Certifications, and approval drawings.

Appendix C—Glossary

This section provides brief definitions of the terms used in this manual.

Index

This section provides a comprehensive index.

Rosemount 1151

MODELS COVERED

This manual provides basic installation, commissioning, and troubleshooting information for the following Rosemount 1151 Pressure Transmitters:

Rosemount 1151DP—Differential Pressure Transmitter

Measures differential pressure up to 1,000 psi (6895 kPa).

Rosemount 1151HP—Differential Pressure Transmitter for High Line Pressures

Provides high line pressure up to 300 psi (2068 kPa).

Rosemount 1151GP—Gage Pressure Transmitter

Measures gage pressure up to 6,000 psi (41369 kPa).

Rosemount 1151AP—Absolute Pressure Transmitter

Measures absolute pressure up to 1,000 psi (6895 kPa).

Rosemount 1151LT—Flange-Mounted Liquid Level Transmitter

Provides precise level and specific gravity measurements up to 2,770 inH₂O (690 kPa) for a wide variety of tank configurations.

Section 2 Installation

Overview	page 2-1
Safety Messages	page 2-2
General Considerations	page 2-4
Mechanical Considerations	page 2-6
Mounting Considerations	page 2-8
Electrical Considerations	page 2-14
Liquid Level Measurement	page 2-18
Installation Options	page 2-21

OVERVIEW

This section is designed to guide you through a successful Rosemount 1151 installation. This section contains an installation flow chart; safety messages; general, mechanical, mounting, and electrical installation information; as well as installation guidance for optional parts. Dimensional drawings for each Rosemount 1151 variation and mounting configuration are included.

Figure 2-1. Rosemount 1151 Installation Flowchart.

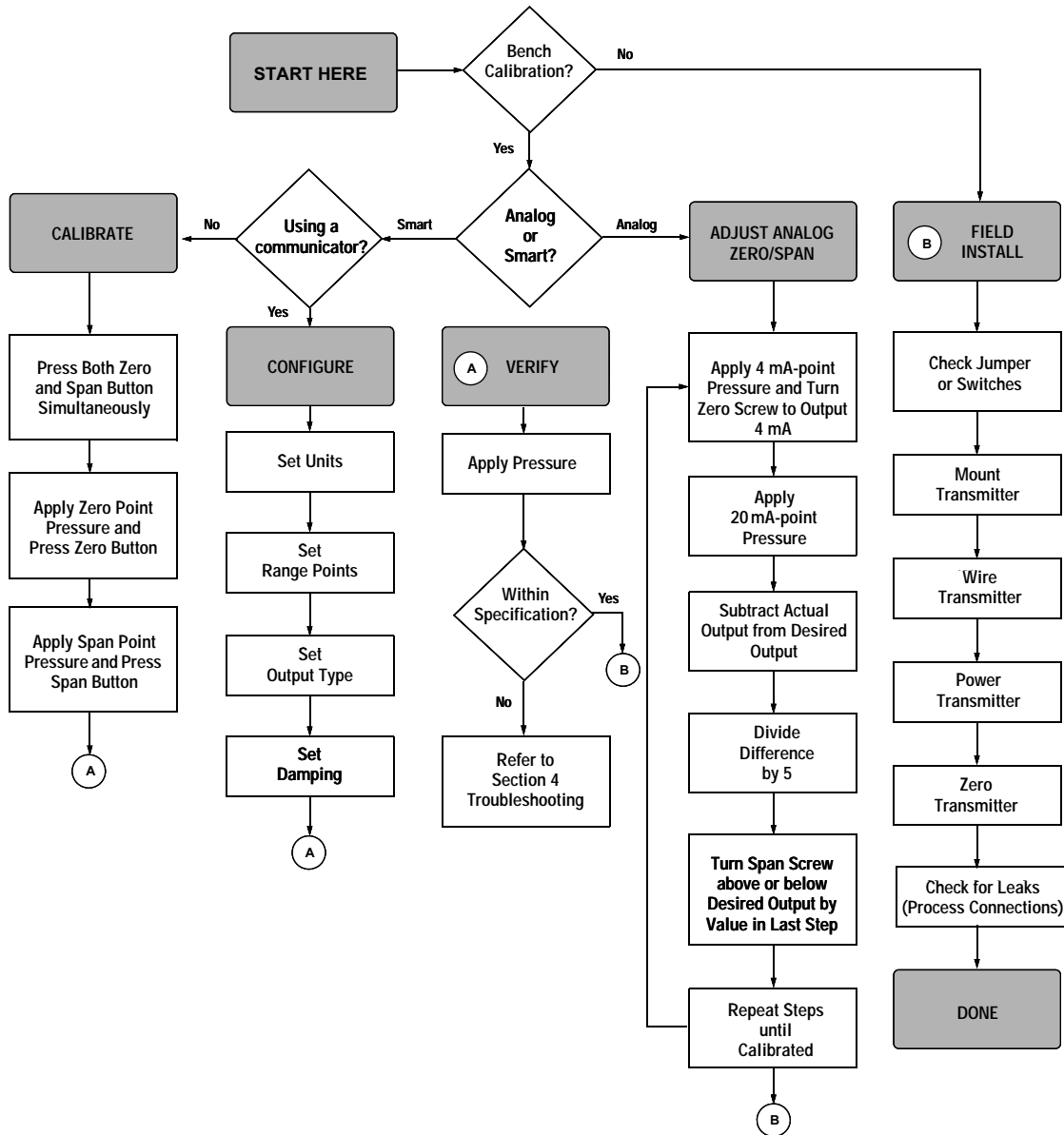

SAFETY MESSAGES

Warnings (⚠)

Procedures and instructions in this section that raise potential safety issues are indicated by a warning symbol (⚠). Refer to the following warning messages before performing an operation preceded by this symbol.

⚠ WARNING

- Explosions can result in death or serious injury. Before connecting a communicator in an explosive atmosphere, make sure the instruments in the loop are installed in accordance with intrinsically safe or nonincendive field wiring practice.
- Process leaks can cause death or serious injury. Install and tighten all four flange bolts before applying pressure, or process leakage may result. Attempting to remove the flange bolts while the transmitter is in service may cause process fluid leaks.
- All explosion-proof, flameproof, and dust-ignition-proof installations require insertion of conduit plugs in all unused openings with a minimum of 40 ft-lb (54 N-m) of torque. This will maintain five full threads of engagement.
- When adding a meter option to a Rosemount 1151 with an Option Code R1 terminal block, make sure to change to cemented meter covers with a glass window. Make sure a sticker is located inside the cover that indicates a "cemented cover." This cover is required to maintain explosion-proof approval.
- Explosions can cause death or serious injury. Do not remove the instrument cover in explosive atmospheres when the circuit is alive.
- Explosions can cause death or serious injury. To meet hazardous location requirements, any transmitter with a tag specifying Option Codes I5, I1, N1, I8, I7, or N7 requires an intrinsically safe analog display (Part Nos. 01151-2614-0004 through 0009) or an LCD Display (Part Nos. 01151-1300-1000, 01151-1300-1001).

⚠ WARNING

Failure to install proper flange adapter O-rings may cause process leaks, which can result in death or serious injury. The two flange adapters are distinguished by unique O-ring grooves. Only use the O-ring that is designed for its specific flange adapter, as shown below.

ROSEMOUNT 3051S / 3051 / 2051 / 3001 / 3095 / 2024

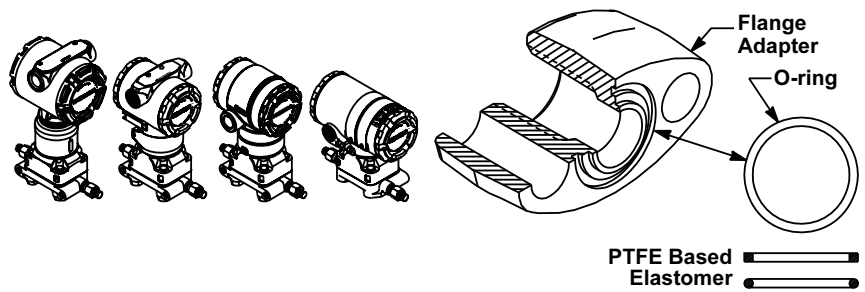

ROSEMOUNT 1151

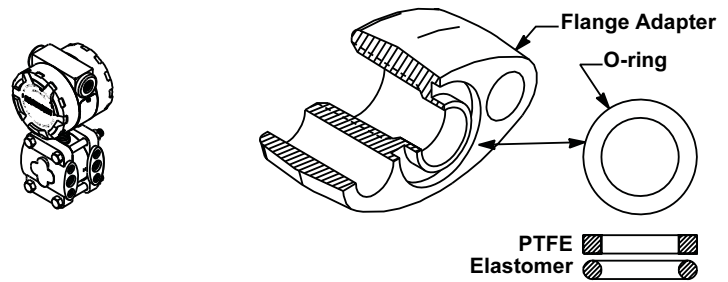

GENERAL CONSIDERATIONS

The accuracy of a flow, pressure, or level measurement depends on proper installation of the transmitter and impulse piping. The piping between the process and transmitter must accurately transmit process pressure to the transmitter. Mount the transmitter close to the process and use a minimum of piping to achieve best accuracy. However, keep in mind the need for easy access, safety of personnel, practical field calibration, and a suitable transmitter environment.

In general, install the transmitter so as to minimize vibration, shock, and temperature fluctuations.

Installations in food, beverage, and pharmaceutical processes may require sanitary seals and fittings. Regulations may dictate special installation requirements to maintain sanitation and cleanability. See www.emersonprocess.com for more information about sanitary pressure instruments.

Transmitter Access Requirements

When choosing an installation location and position, take into account the need for access to the transmitter.

Process Flange Orientation

Orient the process flanges to enable process connections to be made. For safety reasons, orient the drain/vent valves so that process fluid is directed down and away from technicians when the valves are used. This can be accomplished by pointing the hole in the outside valve body downward and away.

Housing Rotation

CAUTION

Do not rotate the transmitter housing more than 90 degrees without disconnecting the header board. Exceeding 90 degrees rotation will damage the internal sensor module wiring.

The electronics housing is designed to be rotated up to 90 degrees in order to provide field access to the two housing compartments. (If rotating the housing more than 90 degrees is necessary, follow the transmitter disassembly procedures in Section 5: Troubleshooting.) To rotate the housing up to 90 degrees, loosen the housing lock nut and turn the housing not more than 90 degrees.

NOTE

Seal module threads with Loctite® 222 before retightening housing lock nut (see **Connecting the Electrical Housing to the Sensor on page 5-7.**)

Terminal Side of Electronics Housing

The terminal side is marked on the nameplate located on the side of the transmitter. Mount the transmitter so that the terminal side of the housing is accessible by providing:

- A 3/4-inch clearance for cover removal with no meter
- A 3-inch clearance for cover removal with a meter installed

If practical, provide approximately 6 inches clearance so that a meter may be installed later.

**Circuit Side of
Electronics Housing**

The circuit compartment should not routinely need to be opened when the unit is in service. However, provide 6 inches clearance, if possible, to allow access to the integral zero and span buttons or for on-site maintenance. The circuit side of the housing is marked on the nameplate located on the side of the transmitter.

Exterior of Electronics Housing

The Rosemount 1151 Smart Pressure Transmitter uses the same housing as the Rosemount 1151 Analog. For this reason, integral span and zero screws—non-functional on the Rosemount 1151 Smart Pressure Transmitter—are located under the nameplate on the side of the transmitter.

MECHANICAL CONSIDERATIONS

Dimensional Drawings

Figure 2-2. Rosemount 1151AP, DP, GP, and HP Dimensional Drawings.

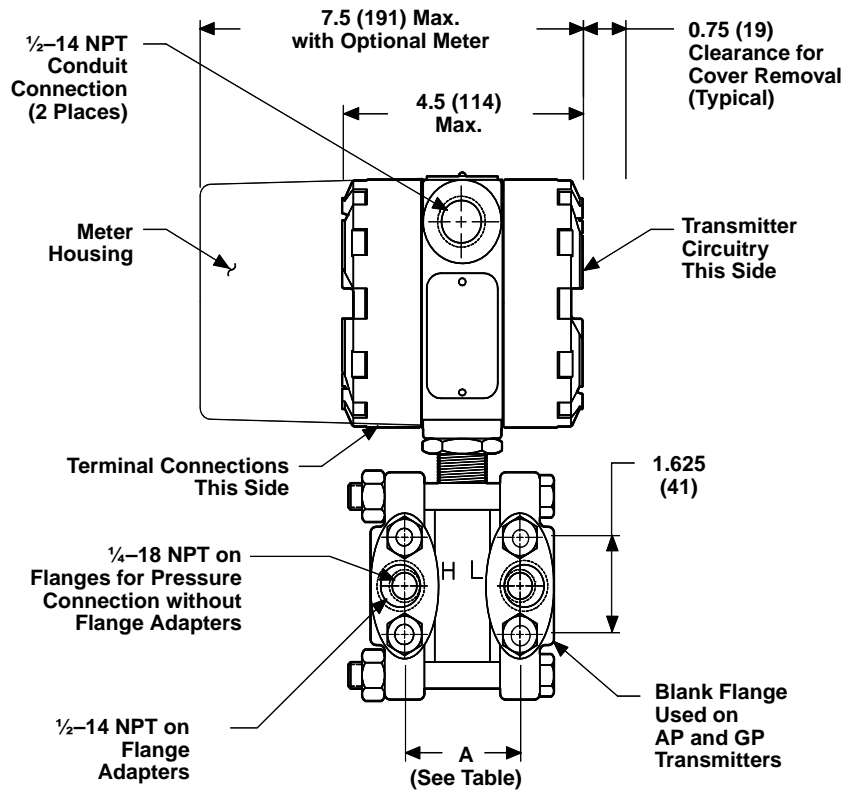

Flange Distance "A" Center to Center		
Range	inches	mm
3, 4, 5	2.125	54
6, 7	2.188	56
8	2.250	57
9	2.281	58
0	2.328	59

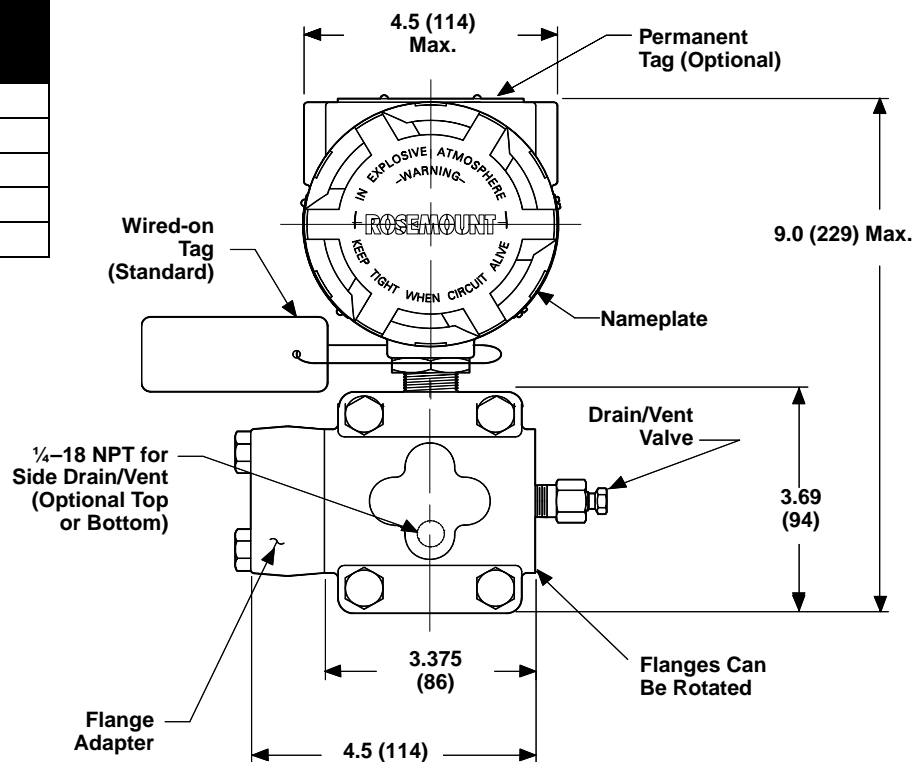

NOTE
Dimensions are in inches (millimeters).

Figure 2-3. Rosemount 1151LT Dimensional Drawing.

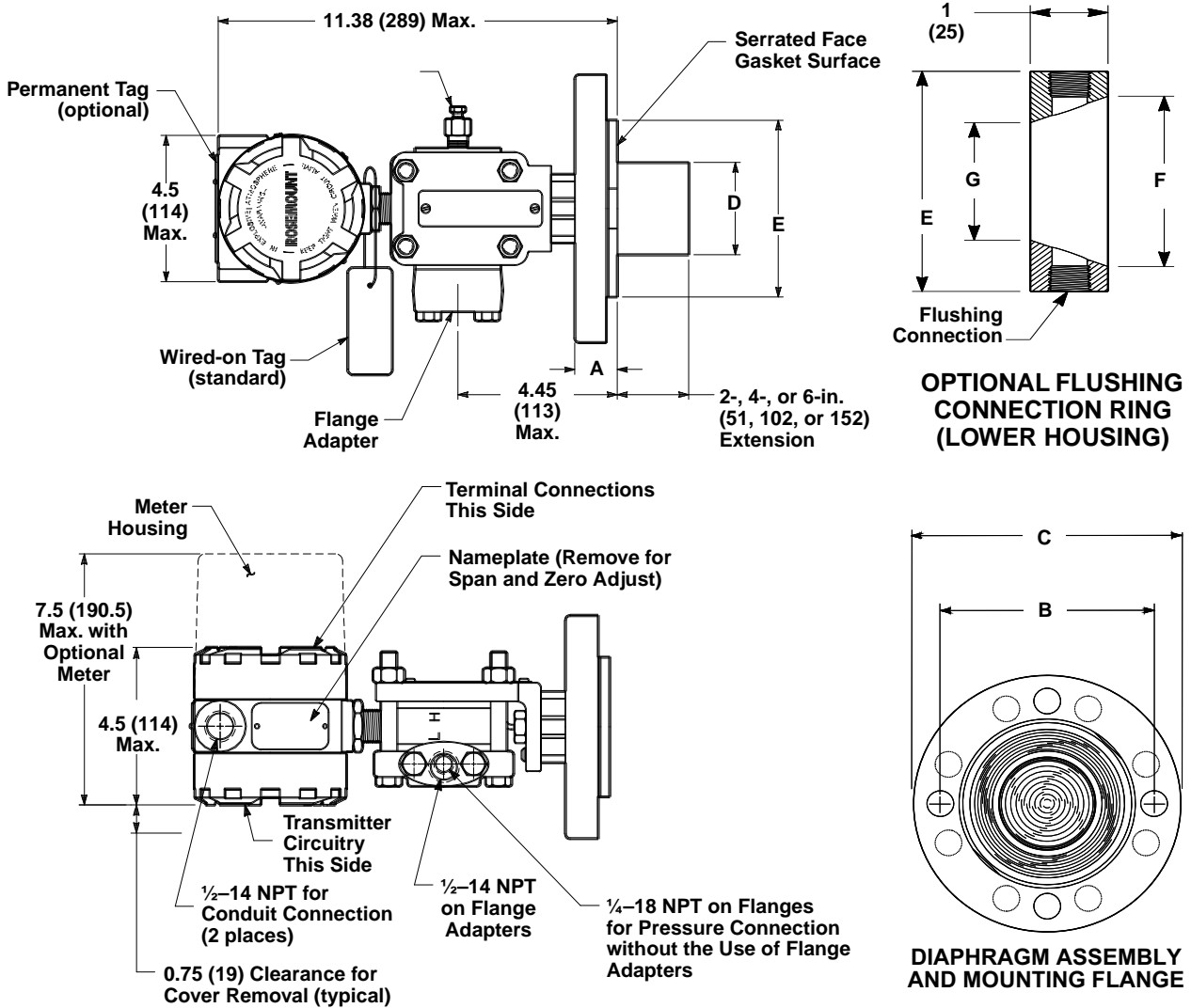

NOTE
 Dimensions are in inches (millimeters).

Table 2-1. Rosemount 1151LT Dimensional Specifications

Class	Pipe Size	Flange Thickness A	Bolt Circle Diameter B	Outside Diameter C	No. of Bolts	Bolt Hole Diameter	Exten. Diam. D ⁽¹⁾	O.D. Gask. Surf. E	Lower Housing	
									Xmtr Side F	Proc. Side G
ANSI 150	2 (51)	1.12 (28)	4.75 (121)	6.0 (152)	4	0.75 (19)	NA	3.75 (95)	2.9 (74)	2.16 (55)
	3 (76)	1.31 (33)	6.0 (152)	7.5 (190)	4	0.75 (19)	2.58 (65)	5.0 (127)	3.11 (79)	3.11 (79)
	4 (102)	1.31 (33)	7.5 (190)	9.0 (228)	8	0.75 (19)	3.5 (89)	6.81 (173)	4.06 (103)	4.06 (103)
ANSI 300	2 (51)	1.25 (32)	5.0 (127)	6.5 (165)	8	0.75 (19)	NA	3.75 (95)	2.9 (74)	2.16 (55)
	3 (76)	1.50 (38)	6.62 (168)	8.25 (209)	8	0.88 (22)	2.58 (65)	5.0 (127)	3.11 (79)	3.11 (79)
	4 (102)	1.62 (41)	7.88 (200)	10.0 (254)	8	0.88 (22)	3.5 (89)	6.81 (173)	4.06 (103)	4.06 (103)
ANSI 600	2 (51)	1.12 (28)	5.0 (127)	6.5 (165)	8	0.75 (19)	NA	3.75 (95)	2.9 (74)	2.16 (55)
	3 (76)	1.37 (35)	6.62 (168)	6.62 (168)	8	0.88 (22)	2.58 (65)	5.0 (127)	3.11 (79)	3.11 (79)
DIN PN10-40	DN 50	26 mm	125 mm	165 mm	4	18 mm	NA	95 mm	74 mm	55 mm
DIN PN 25/40	DN 80	30 mm	160 mm	200 mm	8	18 mm	65 mm	127 mm	79 mm	79 mm
	DN 100	30 mm	190 mm	235 mm	8	22 mm	89 mm	173 mm	103 mm	103 mm
DIN PN 10/16	DN 100	26 mm	180 mm	220 mm	8	18 mm	89 mm	173 mm	103 mm	103 mm

(1) Tolerances are 0.040 (1.02), -0.020 (0.51).

Rosemount 1151

MOUNTING CONSIDERATIONS

The Rosemount 1151 Pressure Transmitter weighs 12 lb. (5.4 kg) without a meter and 15 lb. (6.8 kg) with a meter. This weight must be securely supported. The transmitter is calibrated in an upright position at the factory. If this orientation is changed during mounting, the zero point will shift by an amount equivalent to the liquid head caused by the mounting position. For Smart Transmitters, follow "Because a zero trim must be zero-based, it generally should not be used with Rosemount 1151 Smart Absolute Pressure Transmitters. Absolute pressure transmitters reference absolute zero. To correct mounting position effects on a Rosemount 1151 Smart Absolute Pressure Transmitter, perform a low trim within the full sensor trim function. The low trim function provides a "zero" correction similar to the zero trim function but it does not require the input to be zero based." on page 4-5 to correct this shift. For Analog Transmitters, follow "Zero and Span Adjustment" on page 4-15 to correct this shift.

NOTE

Do not plug the low side with a solid plug. Plugging the low side will cause an output shift.

Mounting Requirements (for Steam, Liquid, Gas)

The following information applies to steam, liquid, and gas installations.

Taps

Tap placement is dependent on the type of process being measured, and on whether the transmitter has side drain/vent valves:

- For liquid flow measurement, place taps to the side of the line to prevent sediment deposits, and mount the transmitter beside or below these taps so gases can vent into the process line and away from the transmitter.
- For gas flow measurement, place taps in the top or side of the line and mount the transmitter beside or above the taps so liquid will drain away from the transmitter.
- For steam flow measurement, place taps to the side of the line with the transmitter mounted below them to ensure that the impulse piping stays filled with condensate.
- For transmitters with side drain/vent valves, place taps to the side of the line.

See Figure 2-4 for a diagram of these arrangements.

Figure 2-4. Steam, Liquid, and Gas Service Installation Diagrams.

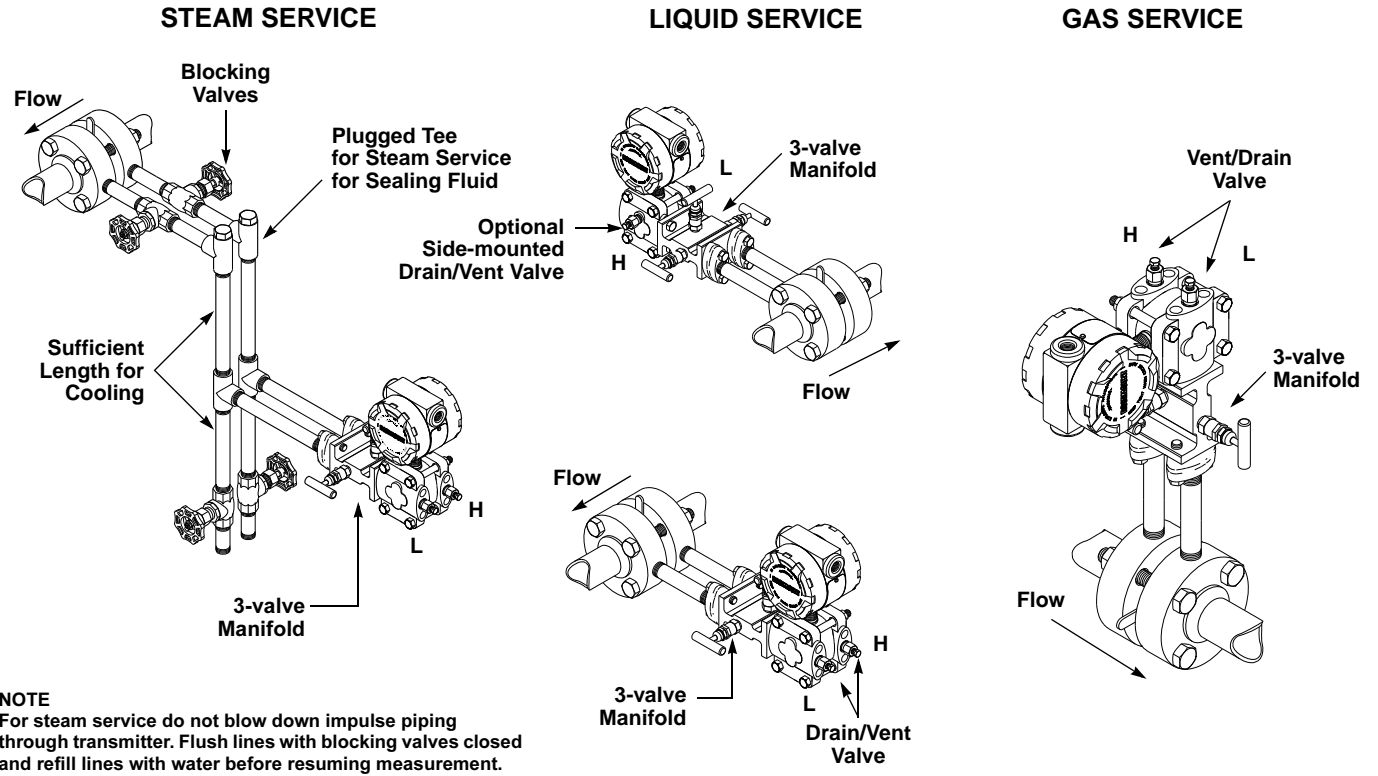

Drain/Vent Valves

Drain/vent valve orientation is also dependent on the process being measured:

- For liquid service, mount the side drain/vent valve upward to allow the gases to vent.
- For gas service, mount the drain/vent valve down to allow any accumulated liquid to drain.

To change the drain/vent valve orientation from top to bottom, rotate the process flange 180 degrees.

Impulse Piping

The piping between the process and the transmitter must accurately transfer the pressure in order to obtain accurate measurements. In this pressure transfer, there are five possible sources of error:

- Leaks
- Friction loss (particularly if purging is used)
- Trapped gas in a liquid line
- Liquid in a gas line
- Temperature-induced or other density variation between the legs

The best location for the transmitter in relation to the process pipe depends on the process itself. Consider the following general guidelines in determining transmitter location and placement of impulse piping:

- Keep impulse piping as short as possible.
- Slope the impulse piping at least 1 inch per foot (8 centimeters per meter) upward from the transmitter toward the process connection for liquid.
- Slope the impulse piping at least 1 inch per foot (8 centimeters per meter) downward from the transmitter toward the process connection for gas.
- Avoid high points in liquid lines and low points in gas lines.
- Make sure both impulse legs are the same temperature.
- Use impulse piping large enough to avoid friction effects and prevent blockage.
- Vent all gas from liquid piping legs.
- For steam service, fill impulse piping with water to prevent contact of live steam with the transmitter.

CAUTION

Steam or other elevated temperature processes can cause damage to the sensor. Do not allow the temperature inside the process flanges to exceed the transmitter limit of 220 °F (104 °C).

- When using a sealing fluid, fill both piping legs to the same level.
- When purging is necessary, make the purge connection close to the process taps and purge through equal lengths of the same size pipe. Avoid purging through the transmitter.
- Keep corrosive or hot process material out of direct contact with the sensor module and flanges.
- Prevent sediment deposits in the impulse piping.
- Keep the liquid head balanced on both legs of the impulse piping.

Process Connections

⚠ Flange Adaptors:

Rosemount 1151AP, DP, GP, and HP process connections on the transmitter flanges are 1/4–18 NPT. Flange adapters are available with standard 1/2–14 NPT Class 2 connections. The flange adapters allow users to disconnect from the process by removing the flange adapter bolts. Use plant-approved lubricant or sealant when making the process connections. Figure 2-2 shows the distance between pressure connections. This distance may be varied $\pm 1/8$ in. (3.2 mm) by rotating one or both of the flange adapters.

On open vessels, the low-side process flange is open to atmosphere and should be mounted with the threaded hole pointed down. On closed vessels, this connection is used for the dry or wet leg.

High-pressure-side process connections for the Rosemount 1151LT Transmitter are offered with 2-, 3-, or 4-in., Class 150, 300, or 600 flanges; DN 50 (PN 10-40), DN 80 (PN 25/40), or DN 100 (PN 10/16, 25/40).

Low-pressure-side process connections for the Rosemount 1151LT Transmitter are offered with 1/4–18 NPT on the flange, and 1/2–14 NPT on the adapter.

O-rings:

The two styles of Rosemount flange adapters (Rosemount 1151 and Rosemount 3051/2024/3001/3095/2051) each require a unique O-ring (see Figure 2-5). Use only the O-ring designed for the corresponding flange adaptor.

Figure 2-5. O-Rings.

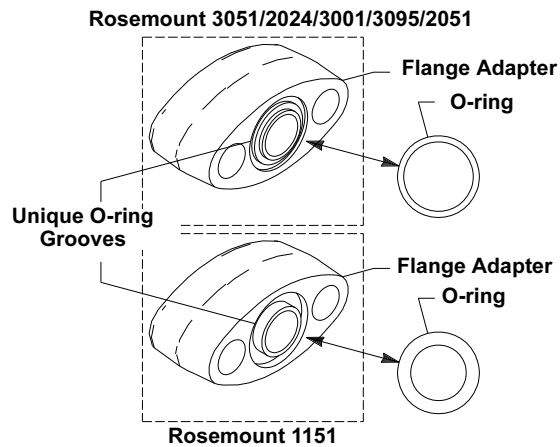

⚠ When compressed, PTFE O-rings tend to “cold flow,” which aids in their sealing capabilities.

NOTE

PTFE O-rings should be replaced if the flange adapter is removed.

Tightening the Seal:

To ensure a tight seal on the flange adapters or a three-valve manifold, first finger-tighten both bolts, then wrench-tighten the first bolt to approximately 29 ft.-lbs (39 N-m). Wrench-tighten the second bolt to approximately 29 ft.-lbs (39 N-m).

Mounting Brackets

Optional mounting brackets permit mounting the transmitter to a wall, a panel, or a 2-inch horizontal or vertical pipe. Figure 2-6 illustrates some typical configurations these mounting brackets.

Table 2-2. Mounting Brackets

Option Code	Mounting		Material			
	Pipe Mount	Panel Mount	CS Bracket	SST Bracket	CS Bolts	SST Bolts
B1	X		X		X	
B3		X	X		X	
B4	X		X			X
B6		X	X			X
B7	X			X		X
B9		X		X		X

Figure 2-6. Mounting Bracket Option Codes B1, B4, and B7.

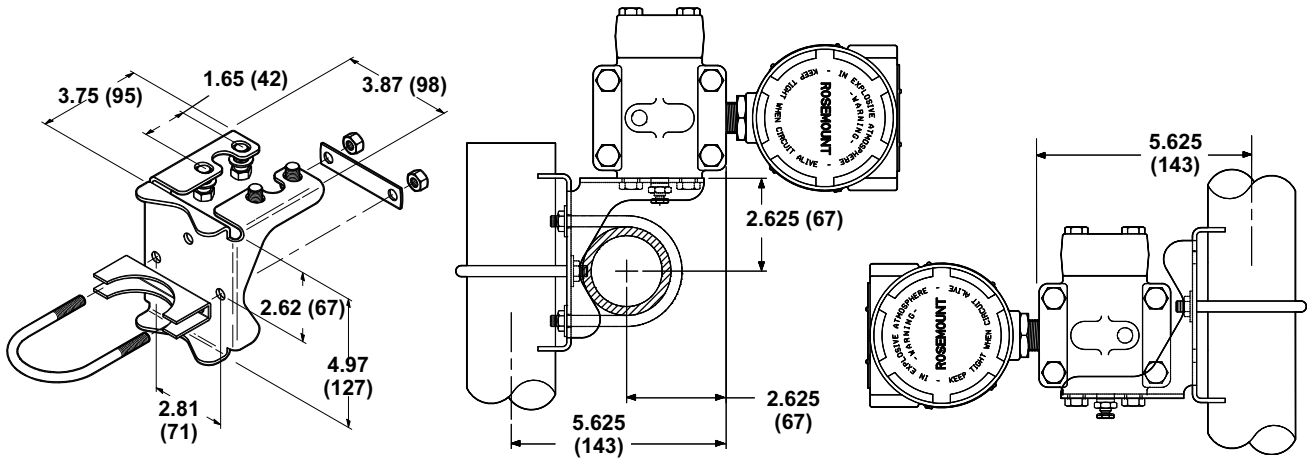

Figure 2-7. Panel Mounting Bracket Option Codes B2, and B5

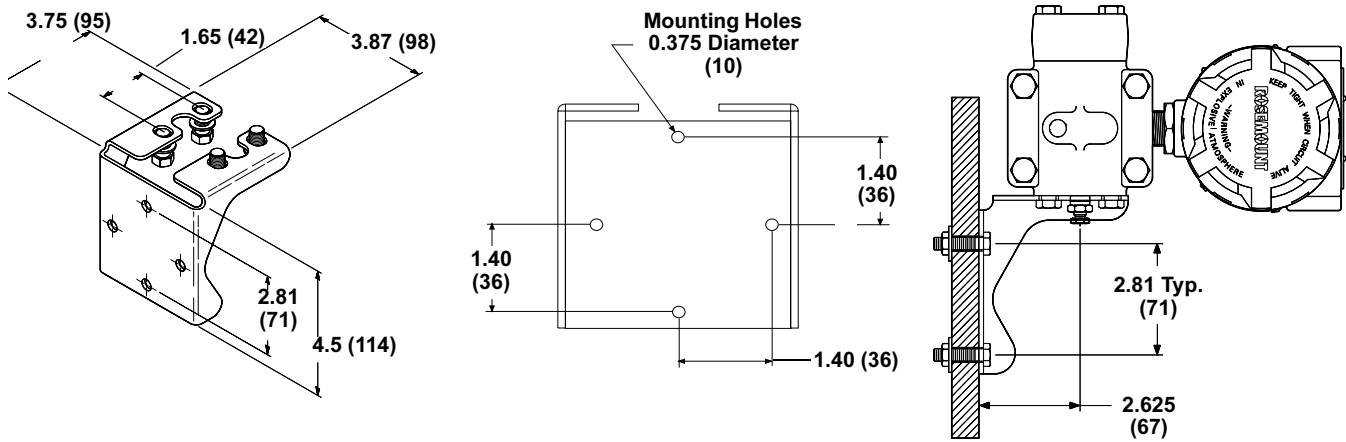
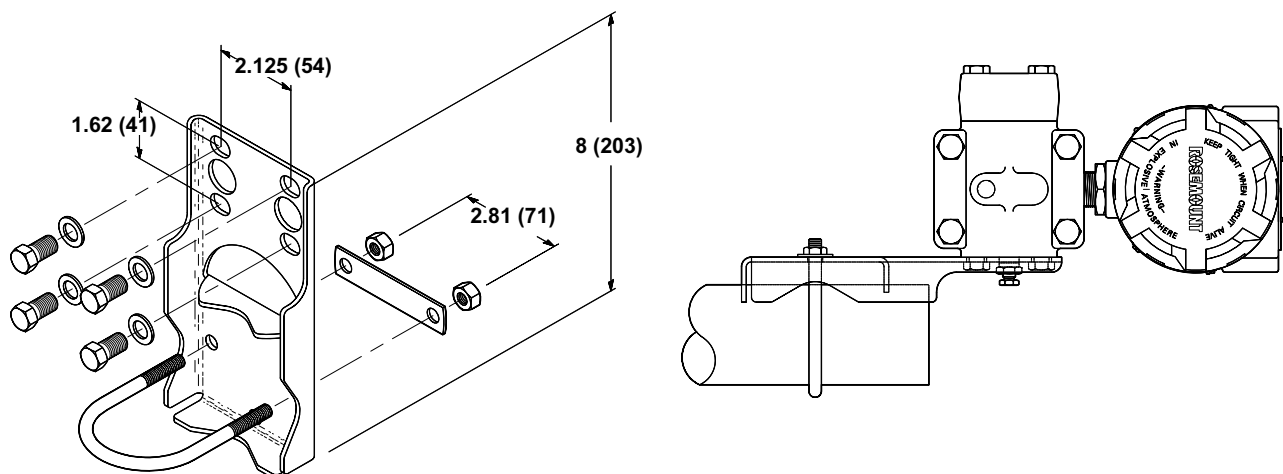

Figure 2-8. Flat Mounting Bracket Option Codes B3, B6, and B9



NOTE
 Dimensions are in inches (millimeters).

ELECTRICAL CONSIDERATIONS

NOTE

Make sure all electrical installation is in accordance with national and local code requirements.

Power Supply

The DC power supply should provide power with less than 2% ripple. The total load is the sum of the resistance of the signal leads and the load resistance of the controller, indicator, and related pieces. The resistance of intrinsic safety barriers, if used, must be included. Figure 2-7 illustrates power supply load limitations for the transmitter.

Figure 2-7. Power Supply Load Limitations.

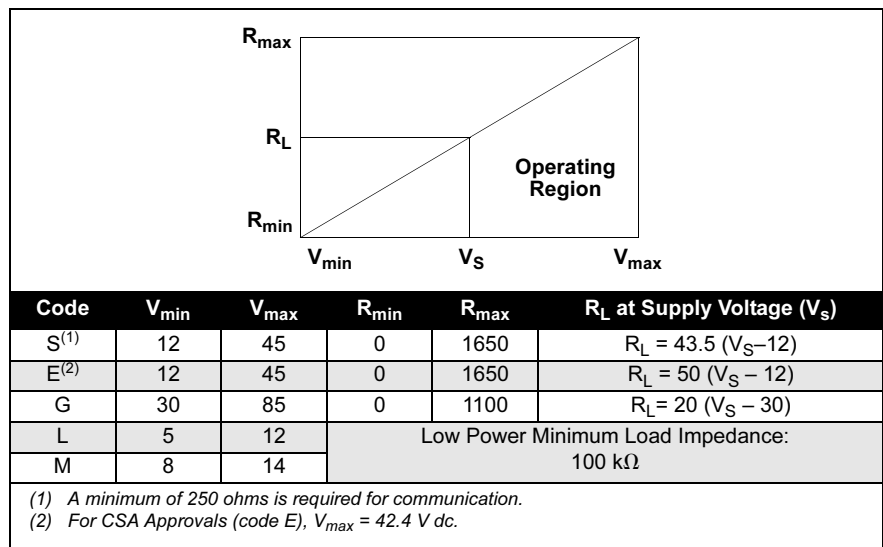

Conduit Installation

⚠ CAUTION

If all connections are not sealed, excess moisture accumulation can damage the transmitter. Make sure to mount the transmitter with the electrical housing positioned downward for drainage. To avoid moisture accumulation in the housing, install wiring with a drip loop, and ensure the bottom of the drip loop is mounted lower than the conduit connections or the transmitter housing.

Recommended conduit connections are shown in Figure 2-8.

Figure 2-8. Conduit Installation Diagrams.

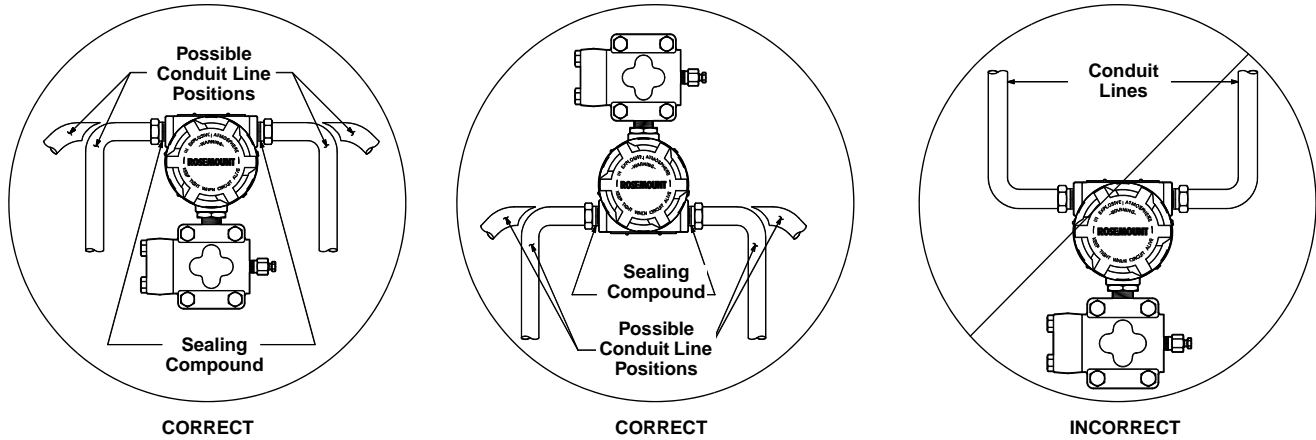

Wiring

⚠ CAUTION

Do not connect the power signal wiring to the test terminals. Voltage may burn out the reverse-polarity protection diode in the test connection. If the test diode is destroyed, then the transmitter can still be operated without local indication by jumping the test terminals.

High voltage (greater than 50 V and greater than 0.005 amperes) can cause damage to the transmitter. Do not apply high voltage to the test terminals.

The signal terminals and test terminals are located in a compartment of the electronics housing that is separate from the transmitter electronics. The nameplate on the side of the transmitter indicates the locations of both of these compartments. The upper pair of terminals are the signal terminals and the lower pair are the test terminals. The test terminals have the same 4–20 mA output as the signal terminals and are only for use with the optional integral meter or for testing.

NOTE

An alternate location to connect an ammeter is on the set of terminals labeled “TEST.” Connect the positive lead of the ammeter to the positive test terminal, and the negative lead of the ammeter to the negative test terminal.

⚠ To make connections, remove the cover on the side marked “Terminal” on the nameplate. All power to the transmitter is supplied over the signal wiring. Connect the lead that originates at the positive side of the power supply to the terminal marked “+” and the lead that originates at the negative side of the power supply to the terminal marked “–”. No additional wiring is required.

Do not run signal wiring in conduit or open trays with power wiring or near heavy electrical equipment.

For improved performance against EMI/RFI effects, refer to “Terminal Blocks” on page 2-24 for information on transient protection terminal blocks.

Shielded cable should be used for best results in electrically noisy environments. Refer to “Grounding” on page 2-16 for more details.

NOTE

When conduit lines are used, signal wiring need not be shielded, but twisted pairs should be used for best results. Wiring must be 24 AWG or larger and not exceed 5,000 feet (1500 meters).

NOTE

A minimum loop resistance of 250 Ω is required to communicate with a hand-held HART-based communicator. With 250 Ω of loop resistance, the transmitter requires a minimum of 17 volts to output 20 mA. If a single power supply is used to power more than one Rosemount 1151 Smart transmitter, the power supply used, and circuitry common to the transmitters should not have more than 20 Ω of impedance at 1200 Hz.

Grounding

⚠ Use the following techniques to properly ground the transmitter signal wiring and case:

Signal Wiring

Do not run signal wiring in conduit or open trays with power wiring or near heavy electrical equipment. It is important that the instrument cable shield be:

- Trimmed close and insulated from touching the transmitter housing
- Connected to the next shield if cable is routed through a junction box
- Connected to a good earth ground at the power supply end

Signal wiring may be grounded at any one point on the signal loop or may be left ungrounded. The negative terminal of the power supply is a recommended grounding point.

Transmitter Case

The transmitter case must be grounded in accordance with national and local electrical codes. The most effective transmitter case grounding method is a direct internal connection to earth ground with minimal impedance. The transmitter case may also be grounded through the process or conduit connections.

Internal Ground Connection: Inside the field terminals side of the electronics housing is the internal ground connection screw. This screw is identified by a ground symbol: .

NOTE

Grounding the transmitter case via threaded conduit connection may not provide sufficient ground continuity.

NOTE

The transient protection terminal block (page 2-25) does not provide transient protection unless the transmitter case is properly grounded. Use the preceding guidelines to ground the transmitter case.

Do not run the transient protection ground wire with signal wiring as the ground wire may carry excessive current if a lightning strike occurs.

Grounding Effects

The capacitance sensing module requires alternating current to generate a capacitance signal. This alternating current is developed in an oscillator circuit with a frequency of approximately 32 kHz. This signal is capacitor-coupled to transmitter-case ground through the sensing module. Because of this coupling, a voltage may be imposed across the load, depending on the choice of grounding. See Figure 2-9.

Impressed voltage, which is seen as high frequency noise, will have no effect on most instruments. Computers with short sampling times in circuits will detect a significant noise signal, which should be filtered out by using a large capacitor (1 μF) or by using a 32 kHz LC filter across the load. Computers that are wired and grounded, as shown in Figure 2-9, are negligibly affected by this noise and do not need filtering.

Figure 2-9. Effects of Grounding on Accuracy for Fast Sample Computers.

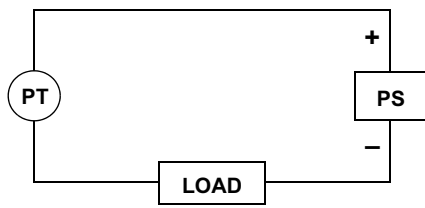

Ungrounded System

Impressed Voltage: 12 to 22 mV_{p-p}
 32 kHz

Effect: 0.01% of span, max.

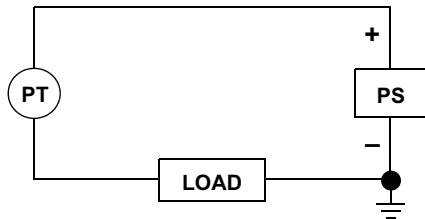

Ground Between Negative Side of Power Supply and Load

Impressed Voltage: 35 to 60 mV_{p-p}
 32 kHz

Effect: 0.03% of span, max.

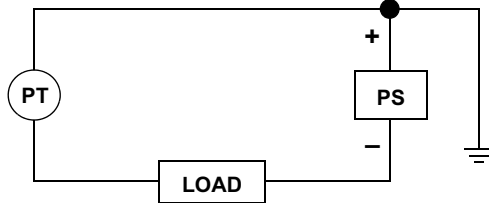

Ground Between Positive Side of Transmitter and Power Supply

Impressed Voltage: 35 to 60 mV_{p-p}
 32 kHz

Effect: 0.03% of span, max.

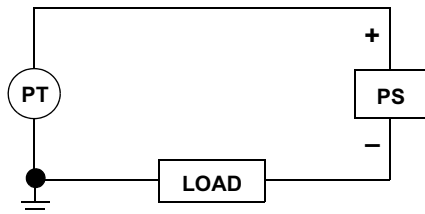

Ground Between Negative Terminal of Transmitter and Load

Impressed Voltage: 500 to 600 mV_{p-p}
 32 kHz

Effect: 0.27% of span, max.

*The effect caused by the impressed voltage on a computer with a sampling time of 100 microseconds using a 2 to 10 volt signal.

Rosemount 1151

Hazardous Locations Certifications

⚠ The Rosemount 1151 was designed with an explosion-proof housing and circuitry suitable for intrinsically safe and nonincendive operation. Factory Mutual explosion-proof certification is standard for the Rosemount 1151 Transmitter. Individual transmitters are clearly marked with a tag indicating the approvals they carry. Transmitters must be installed in accordance with all applicable codes and standards to maintain these certified ratings. Refer to “Hazardous Locations Certifications” on page B-2 for information on these approvals.

Environmental Requirements

Mount the transmitter in an environment that has minimal ambient temperature change. The transmitter electronics temperature operating limits are -40 to 185 °F (-40 to 85 °C). Refer to Section A: Reference Information that lists the sensing element operating limits. Mount the transmitter so that it is not susceptible to vibration and mechanical shock and does not have external contact with corrosive materials.

LIQUID LEVEL MEASUREMENT

Differential pressure transmitters used for liquid level applications measure hydrostatic pressure head. Liquid level and specific gravity of a liquid are factors in determining pressure head. This pressure is equal to the liquid height above the tap multiplied by the specific gravity of the liquid. Pressure head is independent of volume or vessel shape.

Open Vessels

A pressure transmitter mounted near a tank bottom measures the pressure of the liquid above.

Make a connection to the high pressure side of the transmitter, and vent the low pressure side to the atmosphere. Pressure head equals the liquid’s specific gravity multiplied by the liquid height above the tap.

Zero range suppression is required if the transmitter lies below the zero point of the desired level range. Figure 2-10 shows a liquid level measurement example.

Closed Vessels

Pressure above a liquid affects the pressure measured at the bottom of a closed vessel. The liquid specific gravity multiplied by the liquid height plus the vessel pressure equals the pressure at the bottom of the vessel.

To measure true level, the vessel pressure must be subtracted from the vessel bottom pressure. To do this, make a pressure tap at the top of the vessel and connect this to the low side of the transmitter. Vessel pressure is then equally applied to both the high and low sides of the transmitter. The resulting differential pressure is proportional to liquid height multiplied by the liquid specific gravity.

Dry Leg Condition

Low-side transmitter piping will remain empty if gas above the liquid does not condense. This is a dry leg condition. Range determination calculations are the same as those described for bottom-mounted transmitters in open vessels, as shown in Figure 2-10.

Figure 2-10. Liquid Level Measurement Example.

Let **X** equal the vertical distance between the minimum and maximum measurable levels (500 in.).
 Let **Y** equal the vertical distance between the transmitter datum line and the minimum measurable level (100 in.).
 Let **SG** equal the specific gravity of the fluid (0.9).
 Let **h** equal the maximum head pressure to be measured in inches of water.
 Let **e** equal head pressure produced by **Y** expressed in inches of water.
 Let **Range** equal **e** to **e + h**.
 Then $h = (X)(SG)$
 = 500×0.9
 = 450 inH₂O
 $e = (Y)(SG)$
 = 100×0.9
 = 90 inH₂O
Range = 90 to 540 inH₂O

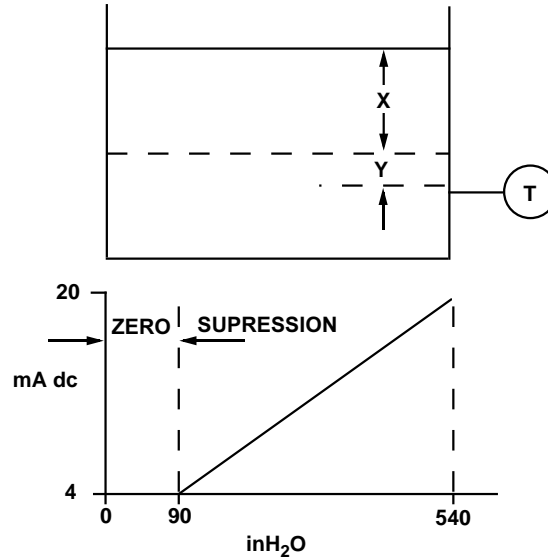

Wet Leg Condition

Condensation of the gas above the liquid slowly causes the low side of the transmitter piping to fill with liquid. The pipe is purposely filled with a convenient reference fluid to eliminate this potential error. This is a wet leg condition.

The reference fluid will exert a head pressure on the low side of the transmitter. Zero elevation of the range must then be made. See Figure 2-11.

Bubbler System in Open Vessel

A bubbler system that has a top-mounted pressure transmitter can be used in open vessels. This system consists of an air supply, pressure regulator, constant flow meter, pressure transmitter, and a tube that extends down into the vessel.

Bubble air through the tube at a constant flow rate. The pressure required to maintain flow equals the liquid's specific gravity multiplied by the vertical height of the liquid above the tube opening. Figure 2-11 shows a bubbler liquid level measurement example.

Figure 2-11. Bubbler Liquid Level Measurement Example.

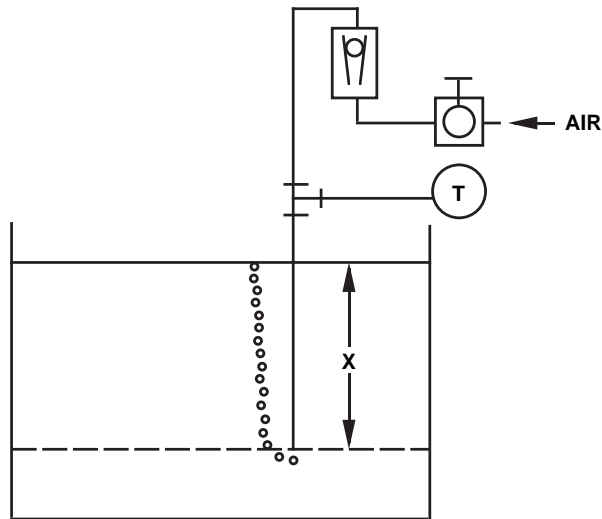

Let **X** equal the vertical distance between the minimum and maximum measurable levels (100 in.).
 Let **SG** equal the specific gravity of the fluid (1.1).
 Let **h** equal the maximum head pressure to be measured in inches of water.
 Let **Range** equal **zero** to **h**.
 Then **h** = **(X)(SG)**
 = 100 x 1.1
 = 110 inH₂O
Range = 0 to 110 inH₂O

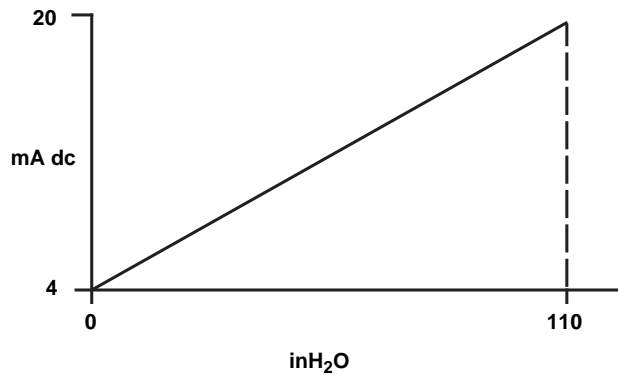

INSTALLATION OPTIONS

Analog Displays

⚠ Option Codes M1, M2, and M6 provide local indication of the transmitter output in a variety of scaling configurations with an indicator accuracy of ± 2 percent. The plug-in mounting configuration allows for simple installation and removal of the analog displays. The meter scaling options are shown below.

- M1 Linear analog display, 0–100% scale
- M2 Square-root analog display, 0–100% flow scale
- M6 Square-root analog display, 0–10√ scale

LCD Displays

The LCD Display Option Codes, M4 and M7–M9, provide a highly accurate local display of the process variable. A variety of scaling configurations are available and listed as follows:

- M4 Linear LCD Display, 0 to 100%
- M7 Special scale LCD Display (specify range, mode, and engineering units)
- M8 Square-root LCD Display, 0 to 100%
- M9 Square-root LCD Display, 0 to 10%

LCD Display Configuration

The Rosemount LCD Display has four digits and plugs directly into the Rosemount 1151 Smart Pressure Transmitter to provide a highly accurate digital display of the process variable. This manual explains the configuration and assembly of the LCD Display and includes the applicable functional, performance, and physical specifications. This meter adds no voltage drop in the 4–20 mA current loop when connected directly across the transmitter test terminals.

The LCD Display may be configured to meet specific requirements by using the left and right calibration buttons located on the meter face as shown in Figure 2-12. The LCD Display cannot be configured for reverse flow because the 20 mA value must always be greater than the 4 mA value. The analog bar graph is also shown in Figure 2-12. The 20-segment bar graph is factory calibrated and represents 4–20 mA directly.

Figure 2-12. LCD Display.

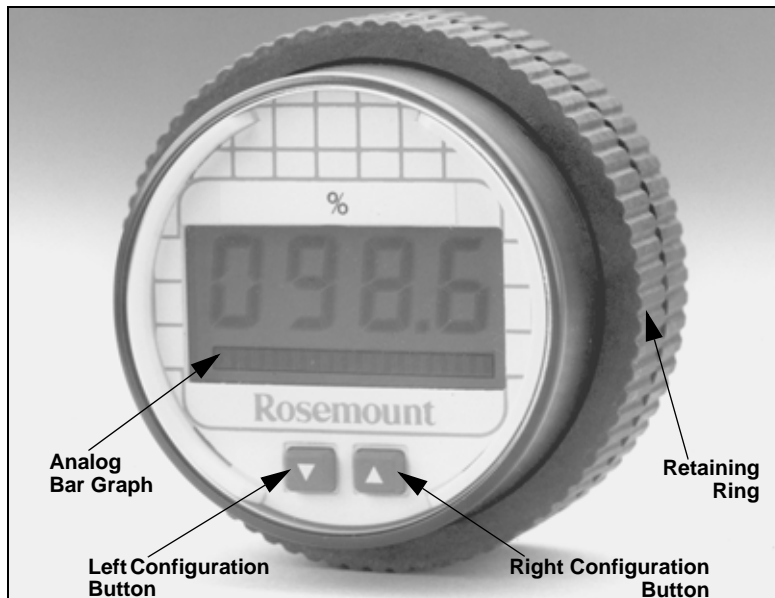

No calibration equipment is required to configure the LCD Display, but between 4 and 20 mA must be flowing through the loop. The actual value of the current is not significant. In addition, meter configuration does not affect the transmitter/loop current. Use the following meter configuration procedure to properly configure the LCD Display:

Remove the Cover

1. Unscrew the retaining ring shown in Figure 2-12 and lift the transparent cover off of the housing.

NOTE

The LCD Display time-out is approximately 16 seconds. If keys are not pressed within this period, the indicator reverts to reading the current signal.

Position the Decimal Point and Select the Meter Function

2. Press the left and right configuration buttons simultaneously and release them immediately.
3. To move the decimal point to the desired location, press the left configuration button.
4. To scroll through the mode options, press the right configuration button repeatedly until the desired mode is displayed.
See Table 2-3.

Table 2-3. LCD Display Modes.

Options	Relationship between Input Signal and Digital Display
L in	Linear
L inF	Linear with five-second filter
Srt	Square root
SrtF	Square root with five-second filter
<p>Square root function only relates to the digital display. The bar graph output remains linear with the current signal.</p> <p>Square root response The digital display will be proportional to the square root of the input current where 4 mA=0 and 20 mA=1.0, scaled per the calibration procedure. The transition point from linear to square root is at 25% of full scale flow.</p> <p>Filter response operates upon "present input" and "input received in the previous five second interval" in the following manner: Display = (0.75 × previous input) + (0.25 × present input) This relationship is maintained provided that the previous reading minus the present reading is less than 25% of full scale.</p>	

Store the Information

5. Press both configuration buttons simultaneously for two seconds. The meter displays "----" for approximately 7.5 seconds while the information is being stored.

Set the Display Equivalent to a 4 mA Signal

6. Press the left button for two seconds.
7. To set the display numbers to a lower value, press the left configuration button, and to set the display numbers to a higher value, press the right configuration button. Set the numbers between -999 and 1000.
8. To store the information, press both configuration buttons simultaneously for two seconds.

Set the Display Equivalent to a 20 mA Signal

9. Press the right button for two seconds.
10. To set the display numbers to a lower value, press the left configuration button, and to set the display numbers to a higher value, press the right configuration button. Set the numbers between -999 and 9999. The sum of the 4 mA point and the span must not exceed 9999. The 20 mA value must be greater than the 4 mA value.
11. To store the information, press both configuration buttons simultaneously for two seconds. The LCD Display is now configured.

Replace the Cover

12. Make sure the rubber gasket is seated properly, replace the transparent cover, and replace the retaining ring.

LCD Display Assembly

Figure 2-13 shows the mounting hardware required to properly install the LCD Display on a transmitter or in the field signal indicator.

Figure 2-13. LCD Display
Exploded View.

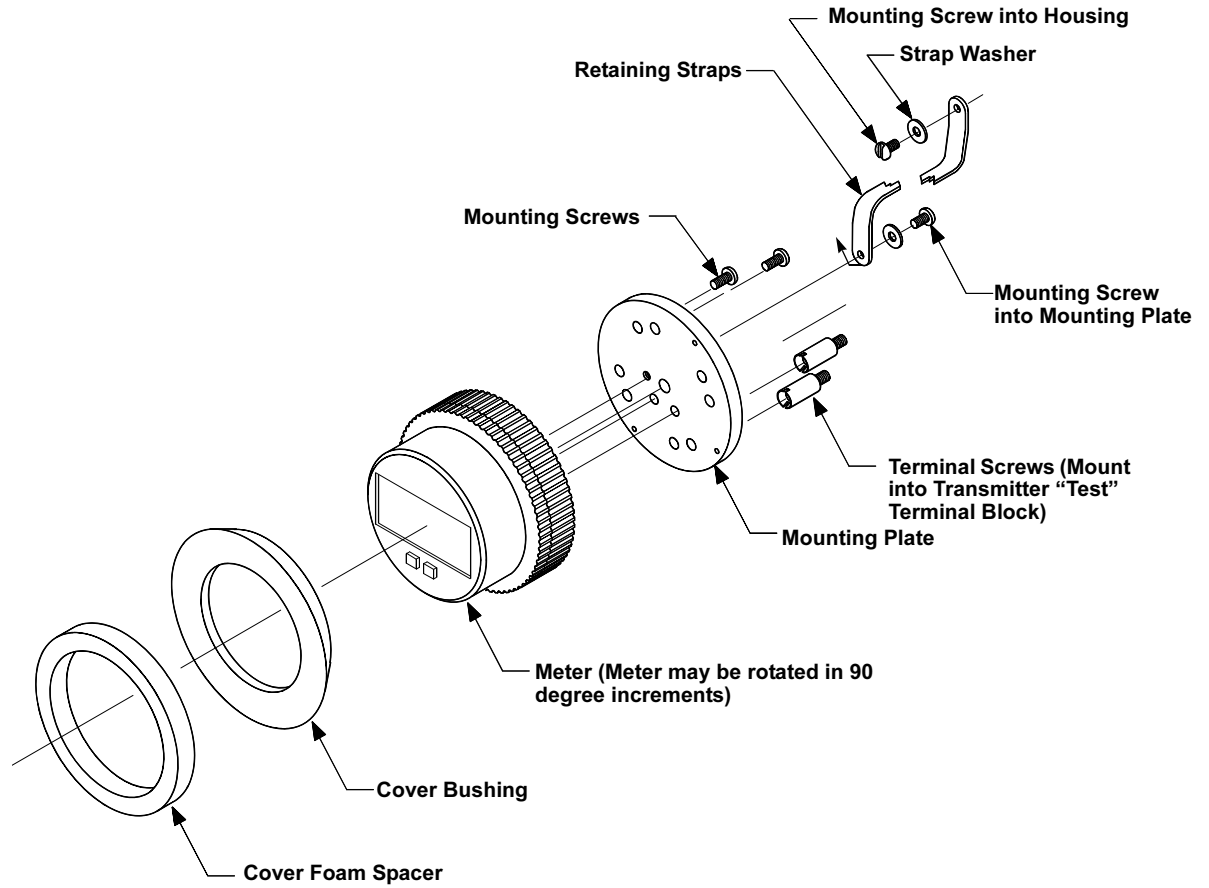

Terminal Blocks

The terminal block options can increase the Rosemount 1151 Pressure Transmitter's ability to withstand electrical transients induced by lightning, welding, heavy electrical equipment, or switch gears. The Rosemount 1151 Pressure Transmitter, with the integral transient protection option, meets the standard performance specifications as outlined in this product manual. In addition, the transient protection circuitry meets IEEE Std 587, Category B, and IEEE Std 472, Surge Withstand Capability.

Figure 2-14. Transient Protection and Filter Terminal Block (Code R1).



Transient Protection and Filter Terminal Block (Option Code R1)

Option Code R1 provides EMI/RFI protection and the benefit of integral transient protection. This terminal block can be ordered as a spare part to retrofit existing Rosemount 1151 Transmitters with Option Code R2.

Terminal Block Installation

Use a Phillips screwdriver, a flat-blade screwdriver and the following steps to install a retrofitable transient protection terminal block:

1. Turn off all power to the Rosemount 1151 on which the terminal block is being installed.
- ⚠ 2. Unscrew the transmitter terminal-side (indicated on the housing nameplate) cover (on the high side of the transmitter) exposing the standard terminal block.
3. Disconnect wiring to the terminal block.
4. Remove the single grounding screw and the two signal terminal screws, with terminal eyelet washers, from the standard terminal block.
5. Set the retrofitable transient protection terminal block into the housing, making sure the ground and signal terminals are properly aligned.
6. Insert the short mounting screws with washers in the mounting holes and tighten the terminal block to the transmitter.
7. Turn the transient protector grounding sleeve, located in the grounding hole, just enough to stabilize the unit on the transmitter. Overtightening the grounding sleeve will shift the terminal block out of alignment.
8. Insert the long grounding screw with the square washer into the grounding hole and tighten.
9. Connect the positive power supply wire to the transient protector terminal screw labeled "+ SIGNAL", and the negative power supply wire to the terminal screw labeled "- SIGNAL."
10. Attach the supplied label to the terminal side transmitter cover.
- ⚠ 11. Replace the terminal side cover on the transmitter.

Section 3 Configuration (Smart Only)

Overview	page 3-1
Safety Messages	page 3-1
Wiring Diagrams	page 3-3
Hart Communicator	page 3-5
Testing the Equipment and the Loop	page 3-6

OVERVIEW

This section contains information on commissioning and operating Rosemount 1151 Smart Pressure Transmitters. Instructions for setting transmitter switches (prior to installation) and explanations of software functions are provided in this section. Also, fast key sequences are listed for each software function.

SAFETY MESSAGES

Warnings (⚠)

Procedures and instructions in this section that raise potential safety issues are indicated by a warning symbol (⚠). Refer to the following warning messages before performing an operation preceded by this symbol.

⚠ WARNING

Explosions can result in death or serious injury. Before connecting a communicator in an explosive atmosphere, make sure the instruments in the loop are installed in accordance with intrinsically safe or nonincendive field wiring practices.

Commissioning the Transmitter on the Bench

Commissioning consists of testing the transmitter, testing the loop, and verifying transmitter configuration data. Rosemount 1151 Smart Pressure Transmitters may be commissioned either before or after installation. The recommendation is to commission the transmitter on the bench before installation. This ensures that all transmitter components are in good working order and heightens familiarity with the device.

To avoid exposing the transmitter electronics to the plant environment after installation, set the failure mode and transmitter security switches during the commissioning stage on the bench.

Setting Hardware Switches

The Rosemount 1151 Smart Pressure Transmitter contains hardware switches that provide user-selectable operation of the failure mode and transmitter security. The switches are located on the electronics assembly just inside the electronics housing cover, as shown in Figure 3-1.

Figure 3-1.
Transmitter Switch Locations.

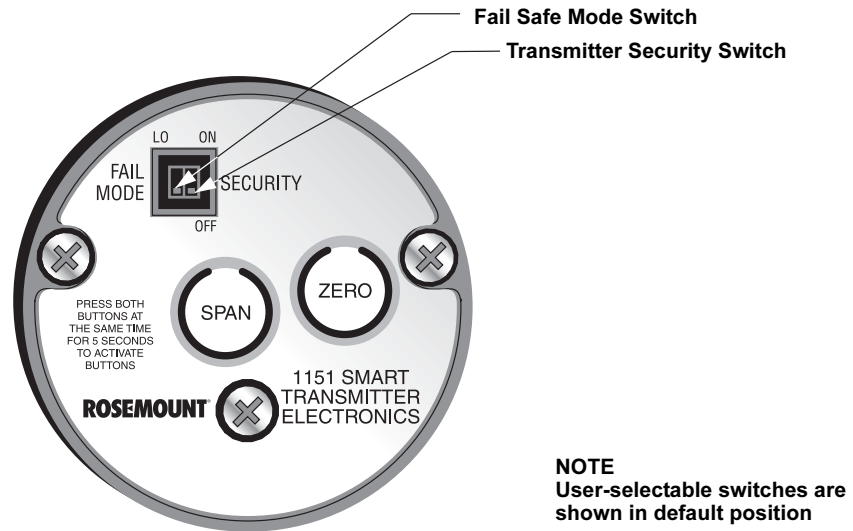

Failure Mode Alarm Switch

As part of its normal operation, the Rosemount 1151 Smart continuously monitors its own operation. This automatic diagnostic routine is a timed series of checks repeated continuously.

The electronics faceplate has HI and LO user-selectable failure mode settings, refer to Figure 3-1. If the diagnostic routine detects a failure in the transmitter in analog output, the transmitter either drives its output below 3.8 mA or above 21.0 mA, depending on the position of the failure mode alarm switch.

NOTE

With multidrop (digital) output, the analog output remains at 4 mA, even when a diagnostic failure is detected. This is true for both the HI and LO fail mode switch settings. A bit is enabled in the digital word to indicate a diagnostic failure.

Transmitter Security (Write-Protection Switch)

Once the transmitter has been configured, it may be desirable to protect the configuration data from changes. The electronics assembly is equipped with a switch labeled SECURITY. Figure 3-1 shows the switch location on the circuit side of the electronics housing. In the ON position, the switch prevents the accidental or deliberate change of configuration data. To enable the sending of configuration data, simply return the transmitter security switch to the OFF position.

NOTE

The transmitter security switch must be in the OFF position before configuration changes can be made to the transmitter configuration.

Commissioning with a HART-Based Communicator

Before putting the Rosemount 1151 Smart Pressure Transmitter into operation, commission the instrument using a HART-based communicator.

⚠ To commission on the bench, connect a 17 to 45 V dc power supply and a current meter. Make connections as shown in Figure 3-2. The power supplied to the transmitter should not drop below the transmitter lift-off voltage. If the transmitter is being configured when the power drops below the lift-off voltage, the configuration information may not be interpreted correctly by the transmitter.

NOTE
To enable communication, a resistance of at least 250 Ω must be present between the communicator loop connection and the power supply.

WIRING DIAGRAMS

Bench Hook-up

After the bench equipment is connected as shown in Figure 3-2, turn on the HART-based communicator. The communicator will search for a HART-compatible device and will indicate when the connection is made. If the connection is not made, the communicator will indicate that no device was found. If this occurs, refer to Section 5 Troubleshooting.

Figure 3-2. Bench Hook-up.

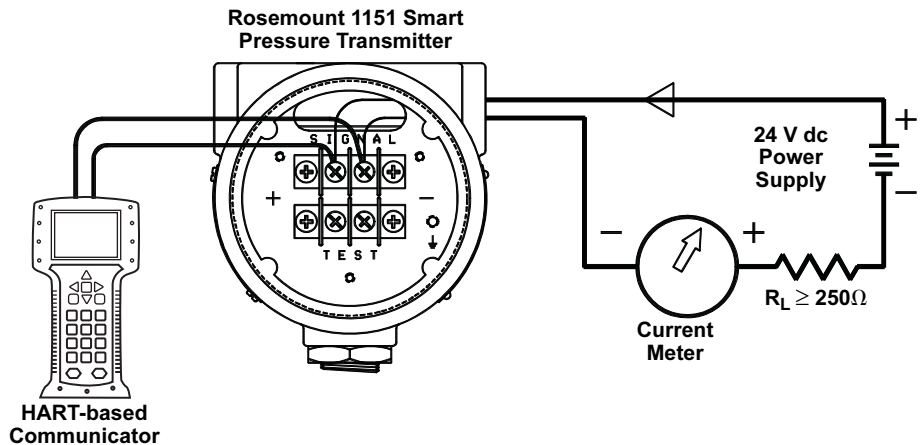

NOTE
An alternate location to connect an ammeter is on the set of terminals labeled "TEST." Connect the positive lead of the ammeter to the positive test terminal, and the negative lead of the ammeter to the negative test terminal.

Rosemount 1151

Field Hook-up

Figure 3-3. Rosemount 1151 Field Wiring Diagram.

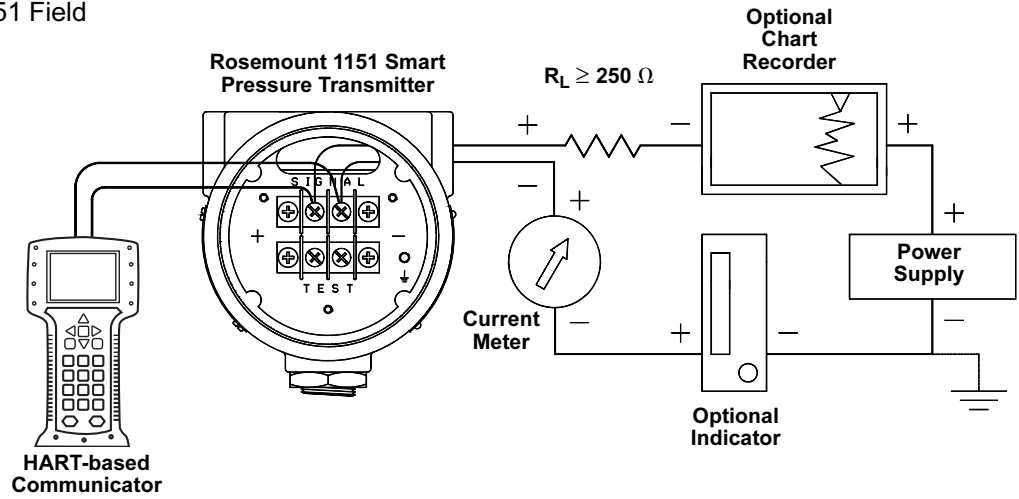

NOTE
 Signal Loop may be grounded at any point or left ungrounded.

NOTE
 A HART Interface may be connected at any termination point in the loop. Signal loop must have 250 ohms minimum load for communications.

HART COMMUNICATOR

Figure 3-4. HART Communicator Menu Tree

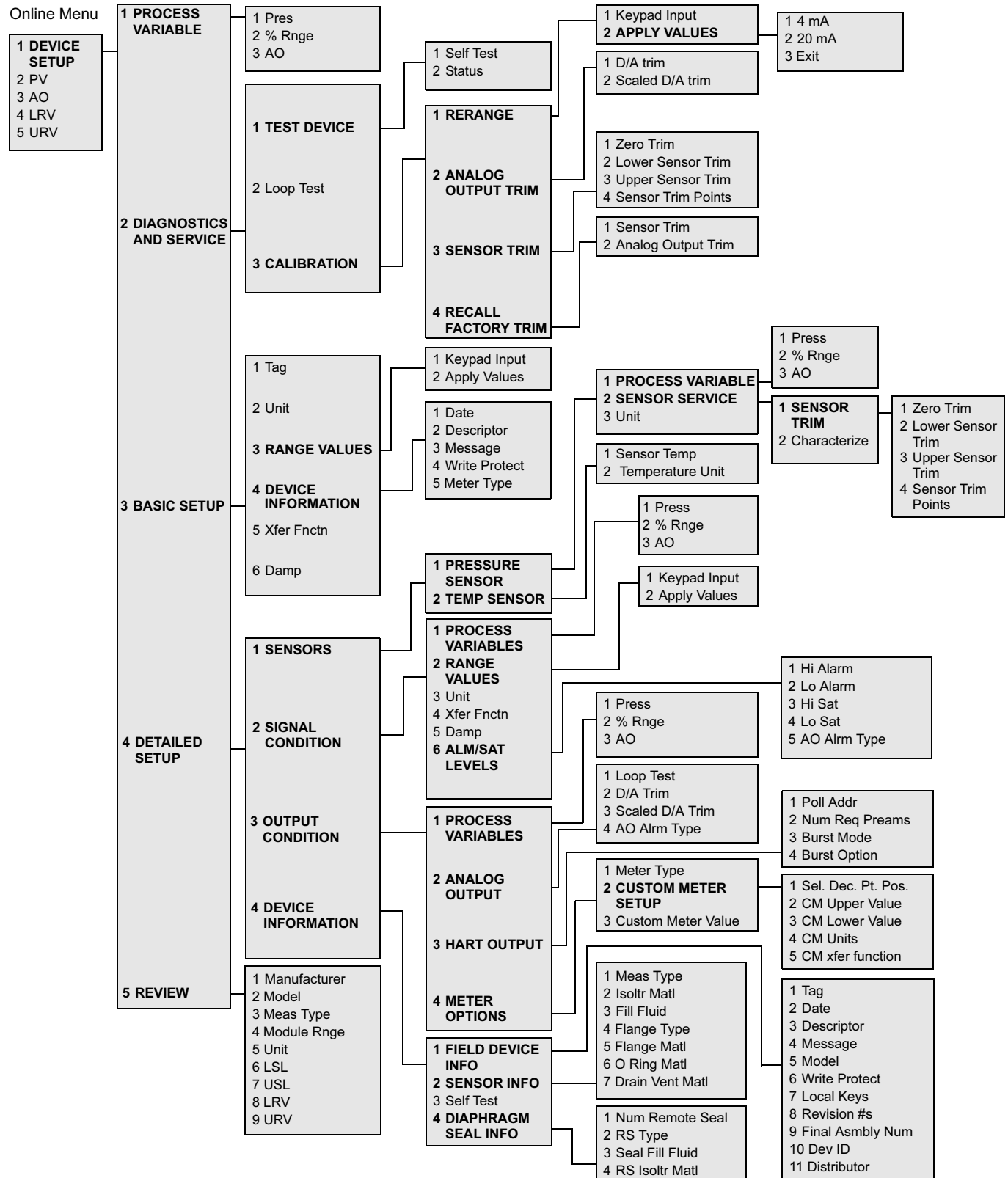

TESTING THE EQUIPMENT AND THE LOOP

Test functions verify that the transmitter, the communicator, and the loop are in good working order. Testing is recommended whenever component failure or a problem with loop performance is suspected.

Communicator Test

A communicator test is performed to ensure the communicator is working properly. The HART Communicator performs a self-test after being turned on. If a problem is detected, the communicator will list a diagnostic message.

Transmitter Test

HART Comm. Fast Key Sequence	1, 2, 1, 1
------------------------------	------------

Although the Rosemount 1151 Smart Pressure Transmitter performs continuous self-diagnostics, a more extensive diagnostic routine can be initiated with the transmitter test function. The transmitter test routine can identify an electronics failure.

If the transmitter test detects a problem, messages to indicate the source of the problem are displayed.

Loop Test

HART Comm. Fast Key Sequence	1, 2, 2
------------------------------	---------

The loop test allows verification of the output of the transmitter, the integrity of the loop, and the operation of any recorders or similar devices. If commissioning the transmitter on the bench, repeat this test after the transmitter has been installed in the field.

A reminder appears to set the loop to manual. Do so and proceed. The next display selects a discrete milliampere transmitter output level. To command the transmitter to output 4 mA, for example, select 4 mA. Check the current meter installed in the test loop to verify that it reads 4 mA. If so, end the loop test. If the output is not 4 mA, then the receiving meter is malfunctioning or the transmitter requires a digital trim as described on page 4-4.

Review Configuration Data

HART Comm. Fast Key Sequence	1, 5
------------------------------	------

Review of the transmitter factory configuration data is recommended.

Checking the Transmitter Output

HART Comm. Fast Key Sequence	2
------------------------------	---

Process variable readings can be obtained in engineering units and milliamperes. If the milliampere display does not agree with the actual loop reading given by a multimeter, a 4–20 mA trim is required.

The last step of start-up and commissioning is to check the transmitter output. Obtain process variable readings in engineering units and milliamperes. If this display does not agree with the actual loop reading given by a multimeter, a 4–20 mA trim is required (see page 4-10).

Range Points

HART Comm. Fast Key Sequence	1, 3, 3
------------------------------	---------

The Rosemount 1151 Smart 4 and 20 mA range points can be viewed and edited with these fast key sequences.

Common Functions

The following tasks are a common part of a transmitter commissioning.

Setting the Loop to Manual

When preparing to send or request data that would disrupt the loop or change the output of the transmitter, set the loop to manual. The HART Communicator will prompt for this setting when necessary. Keep in mind that simply acknowledging this prompter does not set the loop to manual. It is only a reminder; the loop must be set to manual as a separate operation.

Change Non-Output Related Information

The Rosemount 1151 Smart contains several configuration parameters that do not directly affect the transmitter output. These parameters include:

- Date
- Descriptor
- Message
- Meter type

Configure the Analog Output Parameters

Setting Units

HART Comm. Fast Key Sequence	1, 3, 2
------------------------------	---------

By setting the output units, a process can be monitored using the specified units. This is important if a plant uses units which differ from the default values. Output units can be selected from among 14 output options:

• inH ₂ O	• inHg	• ftH ₂ O
• mmH ₂ O	• mmHg	• psi
• bar	• mbar	• g/cm ²
• kg/cm ²	• Pa	• kPa
• torr	• atm	

Reranging

One of the most common configuration tasks involves reranging the transmitter 4 and 20 mA points.

Reranging matches the transmitter range points with the applied process pressures. It can be performed three ways:

- using the communicator only
- using the communicator and a reference pressure
- using the integral zero and span buttons and a reference pressure

Reranging with a Communicator Only

HART Comm. Fast Key Sequence	1, 2, 3, 1, 1
------------------------------	---------------

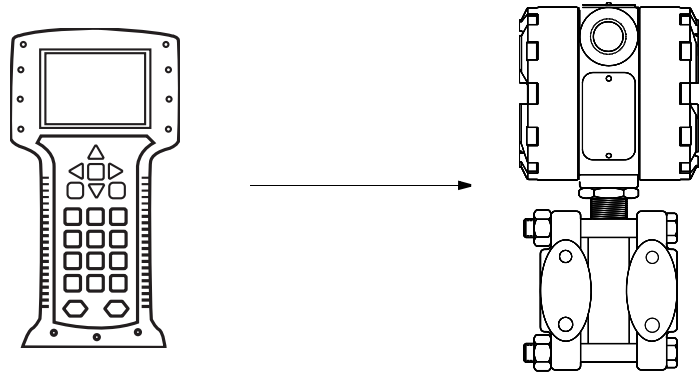

Reranging with only the communicator changes the analog 4 and 20 mA points independently without a pressure input.

This means that when you change either the 4 or 20 mA setting, you also change the span. For instance:

If the transmitter is ranged so that

$$\begin{aligned} 4 \text{ mA} &= 0 \text{ inH}_2\text{O}, \text{ and} \\ 20 \text{ mA} &= 100 \text{ inH}_2\text{O}, \end{aligned}$$

and you change the 4 mA setting to 50 inH₂O using the communicator only, the new settings are:

$$\begin{aligned} 4 \text{ mA} &= 50 \text{ inH}_2\text{O}, \text{ and} \\ 20 \text{ mA} &= 100 \text{ inH}_2\text{O}. \end{aligned}$$

Note that the span was also changed from 100 inH₂O to 50 inH₂O, while the 20 mA setpoint remained at 100 inH₂O.

To obtain reverse output, simply set the 4 mA point at a greater numerical value than the 20 mA point. Using the above example, setting the 4 mA point at 100 inH₂O and the 20 mA point at 0 inH₂O will result in reverse output.

NOTE

The 4 and 20 mA output is based on the transmitter's existing digital calibration. Before reranging with the communicator, make sure the transmitter is correctly interpreting the process variable input. To match the transmitter's reading in engineering units to plant standard, use the sensor trim function under "Digital Trim" in this section.

Reranging with a Communicator and a Reference Pressure

HART Comm. Fast Key Sequence	1, 2, 3, 1, 2
-------------------------------------	---------------

Reranging with a pressure input source and the communicator allows you to maintain the same analog span.

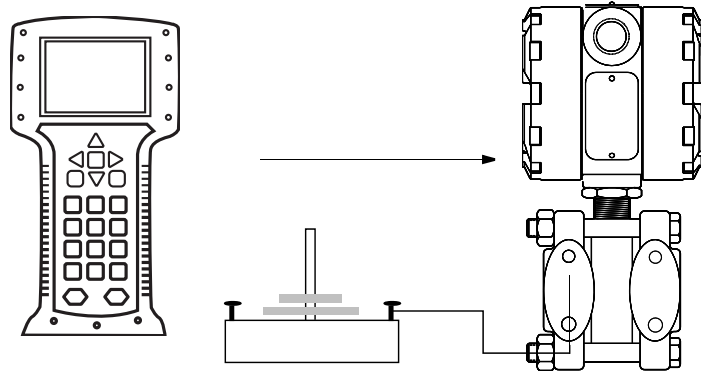

For instance, if the transmitter is ranged so that:

$$\begin{aligned} 4 \text{ mA} &= 0 \text{ inH}_2\text{O}, \text{ and} \\ 20 \text{ mA} &= 100 \text{ inH}_2\text{O}, \end{aligned}$$

and you then change the 4 mA setting to 50 inH₂O using the communicator (or buttons) and a pressure input, the new settings are:

$$\begin{aligned} 4 \text{ mA} &= 50 \text{ inH}_2\text{O} \\ 20 \text{ mA} &= 150 \text{ inH}_2\text{O} \end{aligned}$$

The 100 inH₂O span is maintained.

To rerange with a reference pressure, apply the desired pressure input to represent the 4 or 20 mA point. Allow the variable reading to stabilize for approximately ten seconds. Press either the 4 mA or 20 mA to make this pressure value either point.

It is also important to note that when using a pressure source, the 4 and 20 mA setpoints are based on the transmitter's interpretation of the pressure input provided. It is possible that when a plant standard is input, the transmitter reads it as a slightly different value. Although the 4 and 20 mA setpoints will operate properly within these applied settings, the transmitter's digital output in engineering units may indicate a slightly different value.

The sensor trim function under "Digital Trim" can be used to match the transmitter's reading in engineering units to your plant standard, thereby eliminating any discrepancy.

NOTE

Reranging only the 4 mA or the 20 mA with a pressure input will maintain the initial span width.

NOTE

Do not rerange the transmitter such that the 4 and 20 mA range points—upper range value (URV) and lower range value (LRV)—are outside the high and low digital sensor trim values. To optimize performance, the digital trim span should be equal to or slightly greater than the 4–20 mA span.

Reranging Using the Integral Span and Zero Buttons and a Reference Pressure

It is also possible to rerange the transmitter using the span and zero buttons located within the circuit side of the electronics housing on the electronics faceplate, as shown in Figure 3-5.

Reranging with a pressure input and the zero and span buttons maintains the same analog span.

Figure 3-5. Rosemount 1151 Electronics Faceplate.

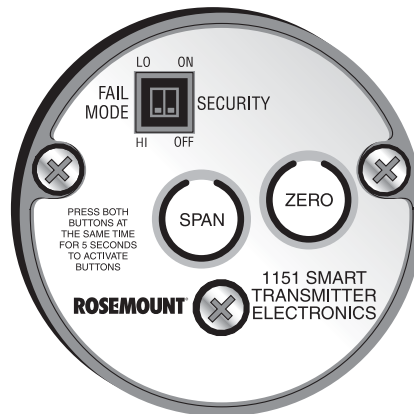

NOTE
User-selectable switches are shown in default position.

Use the following steps to rerange using the integral span and zero buttons:

1. Using a pressure source with an accuracy three to ten times the desired calibrated accuracy, apply a pressure equivalent to the lower calibrated value to the high side of the transmitter.
2. Remove the circuit side cover to expose the span and zero buttons. Hold both the span and zero buttons down simultaneously for at least five seconds to activate the controls. The buttons remain active for 15 minutes. After 15 minutes the buttons must be reactivated by pressing simultaneously and holding again.
3. Press the zero button for five seconds to set the 4 mA point. Verify that the output is 4 mA.
4. Apply a pressure equivalent to the higher calibrated value to the high side of the transmitter.
5. Press the span button for five seconds to set the 20 mA point. Verify that the output is 20 mA.

NOTE

Both the lower and upper range values must fall within the lower and upper range limits of the sensor module, and meet the minimum and maximum span criteria allowed by the transmitter.

Setting Output Type

HART Comm. Fast Key Sequence	1, 3, 5
------------------------------	---------

When the square root output option is active the Rosemount 1151 analog output is proportional to flow. To avoid the extremely high gain that results as the input approaches zero, the Rosemount 1151 automatically switches to a linear output in order to ensure a more stable output near zero. Figure 3-6 illustrates this transition point.

The transition from linear to square root is not adjustable. It occurs at 0.8% of ranged pressure input or 9.0% of full-scale flow output in transmitters with Revision 5.2. software. In earlier software, the transition point occurred at 4.0% of ranged pressure input, or 20% of full scale flow output.

The transition from linear to square root output is smooth, with no step change or discontinuity in output.

Figure 3-6. Square Root Output Transition Point.

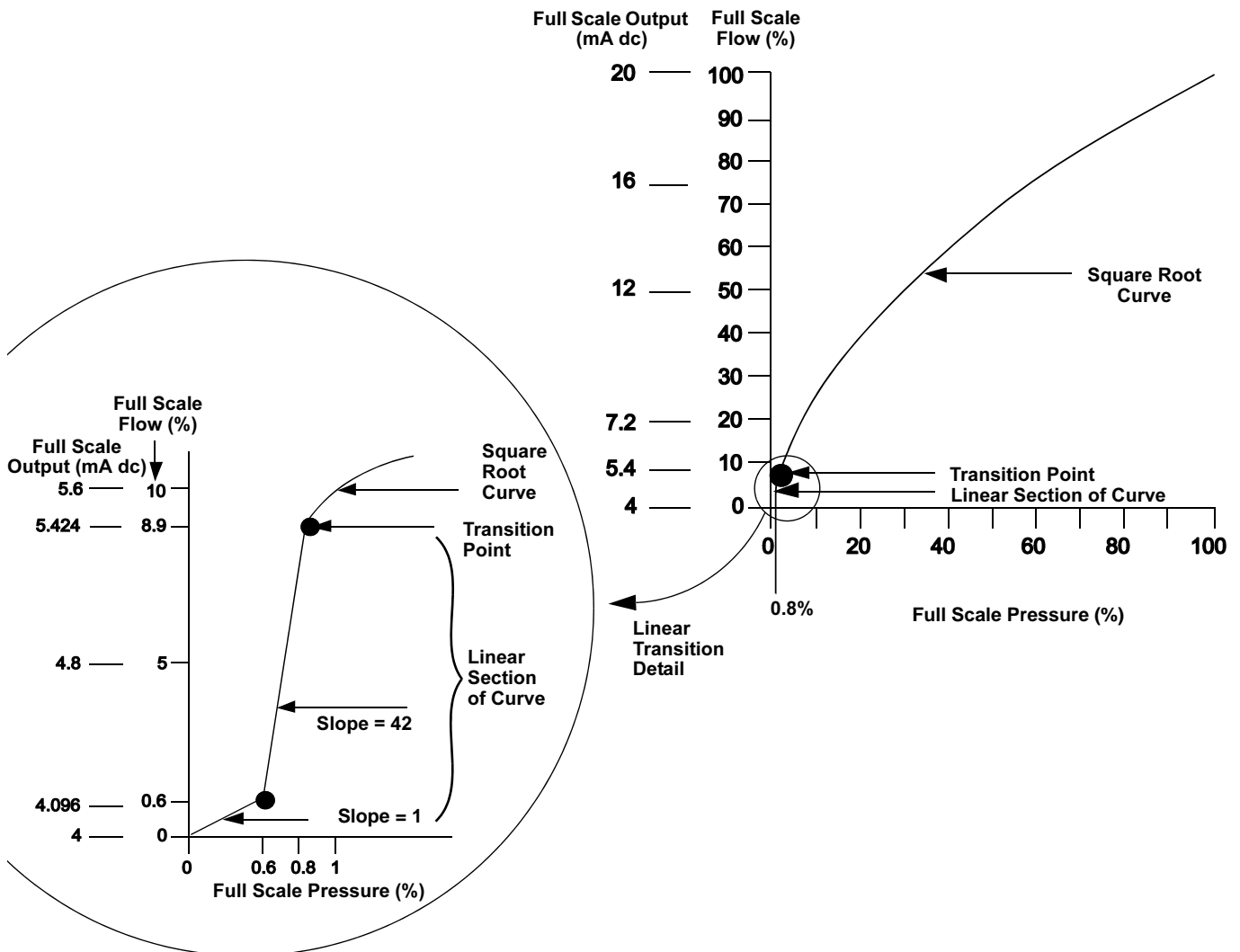

From 0.0 percent to 0.6 percent of the ranged pressure input, the slope of the curve is unity ($y = x$). This allows accurate calibration near zero. Greater slopes would cause large changes in output for small changes at input. From 0.6 percent to 0.8 percent, the slope of the curve equals 42 ($y = 42x$) to achieve continuous transition from linear to square root at the transition point.

Setting Damping

HART Comm. Fast Key Sequence	1, 3, 6
-------------------------------------	---------

The Rosemount 1151 Smart Pressure Transmitter has electronic damping that can increase the response time of the transmitter to smooth the output when there are rapid input variations. High damping values filter out process noise, but response time is decreased. Low damping values increase response time, but process noise can also be detected.

For Rosemount 1151 Smart Pressure Transmitter transmitters, damping values may be set in 0.1 second increments from 0 to 16.0 seconds. The default damping value is 0.2 seconds (0.4 seconds for Range 3). Damping values for inert-filled sensors are slightly higher.

Advanced Functions

Burst Mode

HART Comm. Fast Key Sequence	1, 4, 3, 3, 3
-------------------------------------	---------------

When the Rosemount 1151 Smart is configured for burst mode, it provides faster digital communication from the transmitter to the control system by eliminating the time required for the control system to request information from the transmitter.

Burst mode is compatible with use of the analog signal. Because HART protocol features simultaneous digital and analog data transmission, the analog value can drive other equipment in the loop while the control system is receiving the digital information. Burst mode applies only to the transmission of dynamic data (pressure and temperature in engineering units, pressure in percent of range, and/or analog output in mA or V), and does not affect the way other transmitter data is accessed.

Access to information other than dynamic transmitter data is obtained through the normal poll/response method of HART communication. A HART-based communicator or the control system may request any of the information that is normally available while the transmitter is in burst mode. Between each message sent by the transmitter, a short pause allows the HART-based communicator or a control system to initiate a request. The transmitter will receive the request, process the response message, and then continue "bursting" the data approximately three times per second.

Saving, Recalling, and Cloning Configuration Data

Data that was entered off-line can be stored in the HART-based communicator memory and downloaded to other transmitters later. Data also can be copied from a transmitter in order to be sent to other transmitters in a process known as "cloning." This is especially useful if when working with a large number of transmitters that require the same configuration data.

NOTE

The HART Communicator requires the use of the Transfer Menu to move data between the transmitter memory and the communicator. This menu is available from the Main Menu of the HART Communicator.

Multidrop Communication

Multidropping transmitters refers to the connection of several transmitters to a single communications transmission line. Communication between the host and the transmitters takes place digitally with the analog output of the transmitters deactivated. With the smart communications protocol, up to 15 transmitters can be connected on a single twisted pair of wires or over leased phone lines. Note that burst mode operation is not compatible with multidrop communications.

The application of a multidrop installation requires consideration of the update rate necessary from each transmitter, the combination of transmitter models, and the length of the transmission line. Multidrop installations are not recommended where intrinsic safety is a requirement. Communication with the transmitters can be accomplished with commercially available Bell 202 modems and a host implementing the HART protocol. Each transmitter is identified by a unique address (1-15) and responds to the commands defined in the HART protocol.

Figure 3-7 shows a typical multidrop network. This figure is not intended as an installation diagram. Contact Emerson Process Management product support with specific requirements for multidrop applications.

Figure 3-7. Typical Multidrop Network.

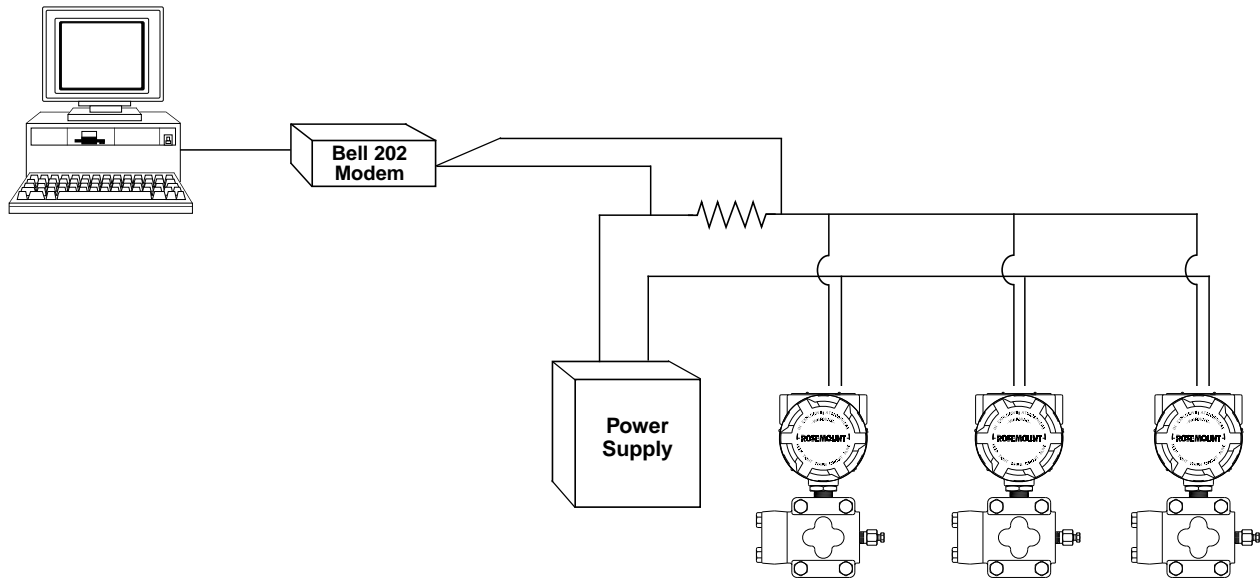

HART-based communicators can test, configure, and format a multidropped Rosemount 1151 in the same way as it can a Rosemount 1151 in a standard point-to-point installation.

NOTE

The Rosemount 1151 Smart Pressure Transmitter is set to address 0 at the factory, allowing it to operate in the standard point-to-point manner with a 4–20 mA output signal. To activate multidrop communication, the transmitter address must be changed to a number between 1 and 15 (inclusive). This change deactivates the 4–20 mA analog output, sending it to 4 mA. It also disables the failure mode alarm signal, which is controlled by the upscale/downscale switch.

Changing a Transmitter Address

HART Comm. Fast Key Sequence	1, 4, 3, 3, 1
-------------------------------------	---------------

To change the address of a multidropped transmitter, follow these fast key sequences. To activate multidrop communication, the transmitter address must be changed to a number from 1 to 15.

Polling a Multidropped Loop

HART Comm. Fast Key Sequence	1, 1, 1
-------------------------------------	---------

Polling a multidropped loop determines the model, address, and number of transmitters on the given loop.

Section 4 Operation and Maintenance

Overview	page 4-1
Safety Messages	page 4-1
Smart Calibration	page 4-2
Analog Calibration	page 4-11

OVERVIEW

This section is separated into two parts: SMART and ANALOG. Go to the correct corresponding pages.

The Operation & Maintenance section contains information on calibration, including the trim functions for the Smart transmitters and hardware adjustments for the analog transmitters.

SAFETY MESSAGES

Warnings (⚠)

Procedures and instructions in this section that raise potential safety issues are indicated by a warning symbol (⚠). Refer to the following warning messages before performing an operation preceded by this symbol.

⚠ WARNING

- Isolate a failed transmitter from its pressure source as soon as possible. Pressure that may be present could cause death or serious injury to personnel if the transmitter is disassembled or ruptures under pressure.
- Explosions can cause death or serious injury. Do not remove the instrument cover in explosive atmospheres when the circuit is alive.
- Explosions can cause death or serious injury. Do not break the housing seal in explosive environments. Breaking the housing seal invalidates the explosion-proof housing rating.
- Process leaks can cause death or serious injury. An incorrectly installed backup ring can destroy the o-ring and cause process leaks. Install the backup ring using the following procedure.
- Exposure to hazardous substances can cause death or serious injury. If a hazardous substance is identified, a Material Safety Data Sheet (MSDS), required by law to be available to people exposed to specific hazardous substances, must be included with the returned goods.
- Explosions can cause death or serious injury. Do not disassemble the glass in the meter cover in explosive atmospheres. Disassembling the glass in the meter cover invalidates the explosion-proof meter rating.

WARNING

- The following performance limitations may inhibit efficient or safe operation. Critical applications should have appropriate diagnostic and backup systems in place. Pressure transmitters contain an internal fill fluid. It is used to transmit the process pressure through the isolating diaphragms to the pressure sensing element. In rare cases, oil leak paths in oil-filled pressure transmitters can be created. Possible causes include physical damage to the isolator diaphragms, process fluid freezing, isolator corrosion due to an incompatible process fluid, etc. A transmitter with an oil fill fluid leak can continue to perform normally for a period of time. Sustained oil loss will eventually cause one or more of the operating parameters to exceed published specifications while a small drift in operating point output continues. Symptoms of advanced oil loss and other unrelated problems include:
 - Sustained drift rate in true zero and span or operating point output or both
 - Sluggish response to increasing or decreasing pressure or both
 - Limited output rate or very nonlinear output or both
 - Change in output process noise
 - Noticeable drift in operating point output
 - Abrupt increase in drift rate of true zero or span or both
 - Unstable output
 - Output saturated high or low

SMART CALIBRATION

Calibration Overview

Complete calibration of the Rosemount 1151 Smart Pressure Transmitter involves the following tasks:

Configuring the Analog Output Parameters

- Setting process variable units (page 3-7)
- Reranging (page 3-7)
- Setting output type (page 3-11)
- Setting damping (page 3-12)

Calibrating the Sensor

- Sensor trim (page 4-5)
- Zero trim (page 4-5)

Calibrating the 4–20 mA Output

- 4–20 mA output trim (page 4-11) or
- 4–20 mA output trim using other scale (page 4-11)

Figure 4-1. Rosemount 1151 Smart Transmitter Data Flow with Calibration Options.

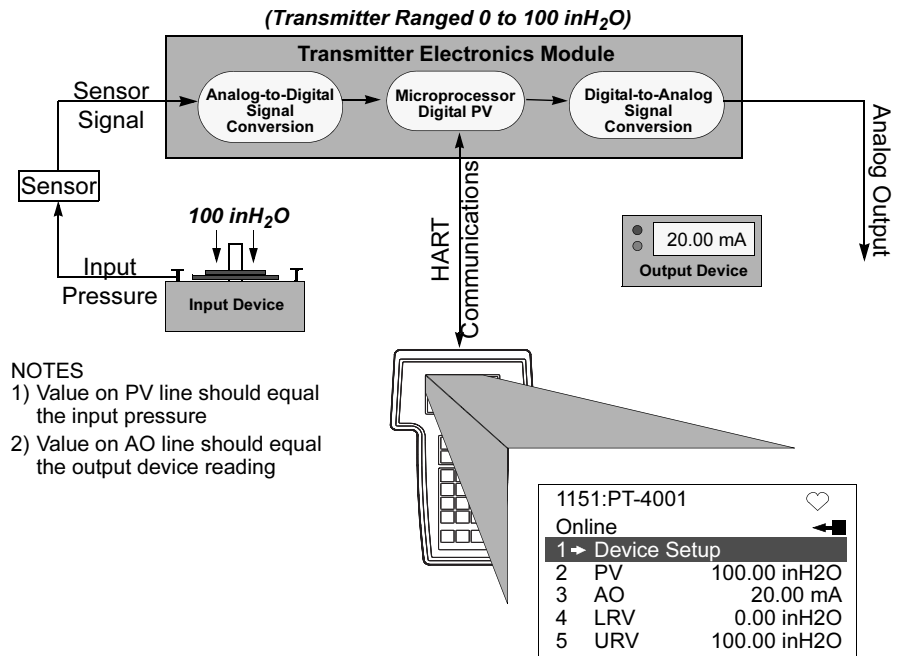

Figure 4-1 illustrates the Rosemount 1151 Smart transmitter data flow. This data flow can be summarized in four major steps:

1. A change in pressure is measured by a change in the sensor output (Sensor Signal).
2. The sensor signal is converted to a digital format that can be understood by the microprocessor (Analog-to-Digital Signal Conversion).
3. Corrections are performed in the microprocessor to obtain a digital representation of the process input (Digital PV).
4. The Digital PV is converted to an analog value (Digital-to-Analog Signal Conversion).

Figure 4-1 also identifies the approximate transmitter location for each calibration task. Note that the data flows from left to right, and a parameter change affects all values to the right of the changed parameter.

Table 4-1 identifies the recommended calibration procedures for each type of Rosemount 1151 Smart transmitter for both bench and field calibration.

Table 4-1. Recommended Calibration Tasks.

Transmitter	Bench Calibration Tasks	Field Calibration Tasks
Standard Calibration Tasks 1151DP 1151GP 1151HP 1151LT	1. Set output configuration parameters: a) Set the Transmitter Range Points. b) Set the Output Units. c) Set the Output Type (linear or square root). d) Set the Damping Value. 2. <i>Optional</i> : Perform a Full Sensor Trim —Pressure source required. 3. <i>Optional</i> : Perform an Analog Output Trim —Multimeter required.	1) Reconfigure parameters if necessary. 2) Zero trim the transmitter to compensate for mounting position effects or static pressure effects.
1151AP	Standard Bench Calibration, except step 2 : 2. <i>Optional</i> : Perform a Full Sensor Trim if equipment is available (accurate <u>absolute</u> pressure source required); otherwise, perform the Low Trim Value section of Full Sensor Trim procedure.	1) Reconfigure parameters if necessary. 2) Perform Low Trim Value section of Full Sensor Trim procedure to correct for mounting position effects.

NOTE
A HART-based communicator is required for all sensor and output trim procedures.

Calibrate the Sensor

Digital Trim (Sensor Trim and Analog Output Trim)

In order to understand the digital trim function, it is necessary to understand that smart transmitters operate differently from conventional analog transmitters. Smart transmitters are characterized, which involves comparing a pressure input with the output of each transmitter’s sensor module. The information obtained in the comparison is stored in the sensor module EEPROM during the characterization process. In operation, the transmitter uses this information to produce a process variable output, in engineering units, dependent on the pressure input. The digital trim function allows corrections to be made to this factory-stored curve.

The digital trim procedure is a two-step process. The first step, called sensor trim, consists of matching the digital process variable reading of the transmitter to a precision pressure input. The second step, called 4–20 mA trim, consists of adjusting the output electronics.

This procedure should not be confused with reranging. Although you can still match a pressure input to a 4 or 20 mA output through a reranging function, you have not affected the transmitter’s interpretation of that input. A *sensor trim* allows you to alter the transmitter’s interpretation of the input signal. A *4–20 mA analog output trim* allows you to alter the transmitter’s conversion of that interpretation into an analog 4–20 mA output.

The transmitter can only be as accurate as the equipment used to perform the digital trim. Use precise equipment under stable, ambient conditions for best results. If such equipment is not available, it may be better to return the transmitter to a local Rosemount service center for verification of the trim values. To eliminate the possibility of over-trimming the transmitter, the Rosemount 1151 Smart will accept only trim values that are within 5 percent of its original characterization.

Sensor Trim

The sensor may be trimmed in two ways: sensor trim and zero trim. They vary in complexity, and their use is application-dependent.

The low trim value should be trimmed first. This provides a stable reference for additional sensor trim adjustment. Adjustment of the low trim value provides an offset correction to the factory-established characterization curve. Adjustment of the high trim value provides a slope or gain correction to the characterization curve based on the low trim value. In neither case is the factory-established characterization curve changed by this procedure. The trim values allow optimized performance over a specified measuring range at the calibration temperature. See Figure 4-3 on page 4-6 for instrumentation set up.

Zero Trim

HART Comm. Fast Key Sequence	1, 2, 3, 3, 1
-------------------------------------	---------------

A **zero trim** is a simpler, one-point adjustment. It must be zero-based (in other words, within 3.0% of true zero) and it may be performed when an exact pressure source is not available for the second pressure needed in a sensor trim.

It is useful for compensating for mounting position effects or for zero shifts due to static pressure in differential pressure applications. However, since this correction maintains the slope of the characterization curve, it should not be used in place of a sensor trim over the full sensor range.

Zero trim is best performed with the transmitter installed in its final mounting position with static pressure applied (or no pressure for a gage transmitter).

NOTE

Because a zero trim must be zero-based, it generally should not be used with Rosemount 1151 Smart Absolute Pressure Transmitters. Absolute pressure transmitters reference absolute zero. To correct mounting position effects on a Rosemount 1151 Smart Absolute Pressure Transmitter, perform a low trim within the full sensor trim function. The low trim function provides a “zero” correction similar to the zero trim function but it does not require the input to be zero based.

Sensor Trim

HART Comm. Fast Key Sequence	1, 2, 3, 3
-------------------------------------	------------

A **sensor trim** is a two-point sensor calibration where two end-point pressures are applied, and all output is linearized between them. To start the procedure, connect the communicator and a pressure input source of at least three times greater accuracy than the Rosemount 1151 Smart Transmitter as shown in Figure 4-3. Always let the variable stabilize for 10 seconds after application of the pressure source before taking its reading.

Figure 4-2. Sensor Trim

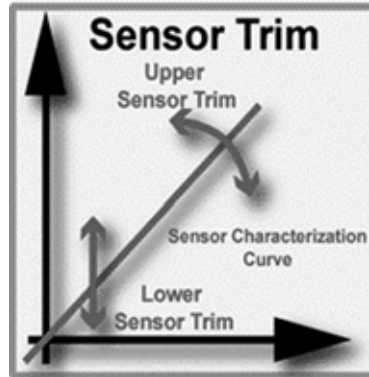
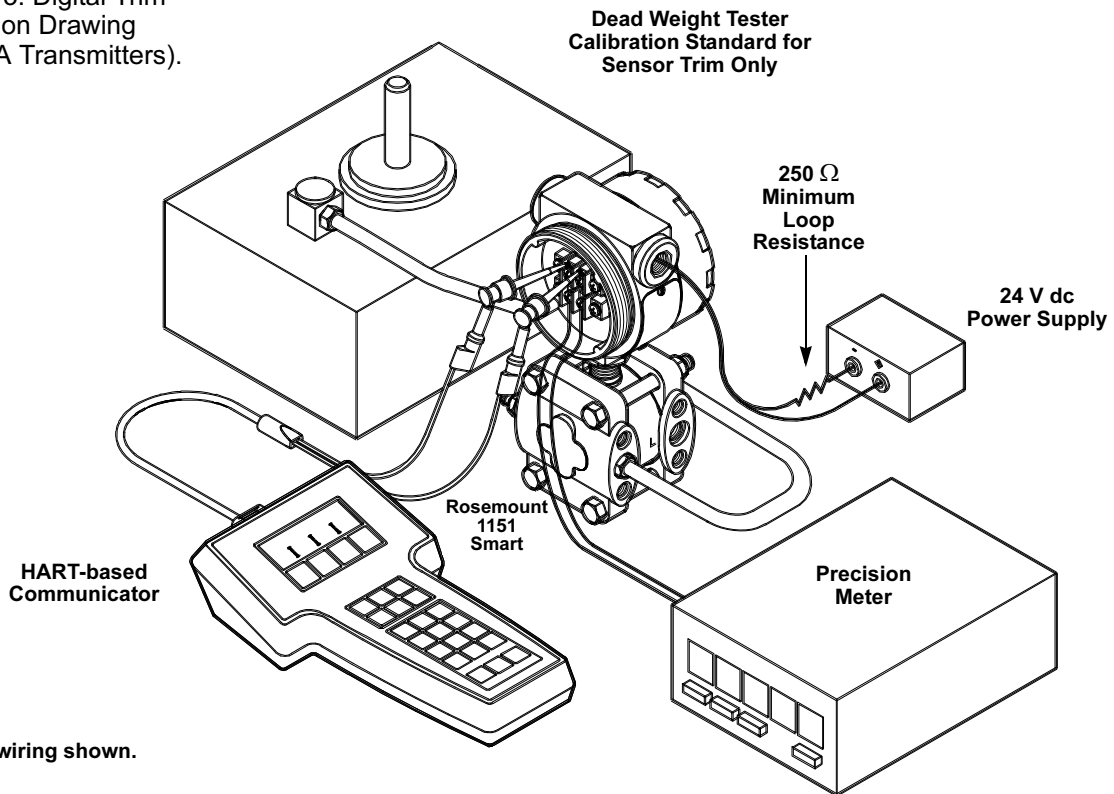

Figure 4-3. Digital Trim Connection Drawing (4–20 mA Transmitters).



NOTE
4–20 mA wiring shown.

NOTE
The Rosemount 1151 Smart Pressure Transmitter allows approximately a 5.0% URL deviation from the characterized curve established at the factory.

NOTE
A sensor trim requires a pressure source at least three times more accurate than the transmitter. For best accuracy, make sure the applied pressure is equal to or slightly less than the desired 4 mA setpoint, or equal to or slightly greater than the 20 mA setpoint.

The last trim/input values used will be displayed briefly. The engineering units shown match those selected under configuration or in transmitter characterization.

In selecting the pressure input values, the low and high values should be equal to or outside the 4 and 20 mA points. Do not attempt to obtain reverse output by reversing the high and low points.

Compensating for High Static Pressure

Systematic Error Correction

One feature of sensor trim is the ability to use it to improve the Rosemount 1151 Smart DP or HP performance by correcting for systematic error because of static pressure.

NOTE

Corrections can only be made in linear mode. Switch from square-root mode to linear mode if necessary.

To better understand the effect of static pressure on the Rosemount 1151DP/HP transmitter, below is a technical description.

Static pressure affects the δ -cell in two independent ways. First, with zero input differential, the effects on the high and low side of the cell tend to cancel each other, but this cancellation may not be complete at higher static pressures. The slight remaining difference in output is called the *Static Pressure Effect On Zero*. While the magnitude of the zero effect is predictable, its direction is not. The effect is repeatable, however, and can be eliminated by simply rezeroing the transmitter at line pressure.

Figure 4-4. δ -Cell™ Construction.

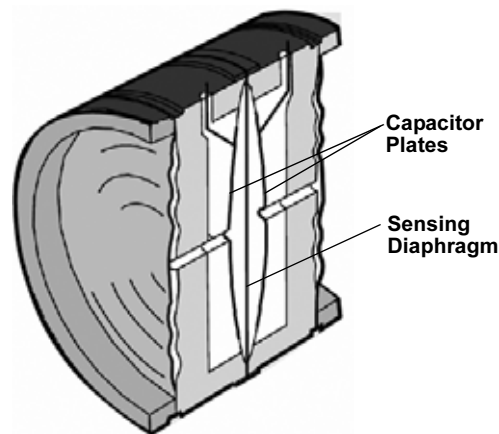

Second, transmitter span is also affected by static pressure. To understand this effect, it is necessary to understand the inner workings of the δ -cell sensor.

The δ -cell sensor is a variable capacitance device. Differential pressure is sensed as a capacitance that varies with the position of a movable plate, or sensing diaphragm, between two fixed plates. See Figure 4-4.

In the actual cell design, the sensing diaphragm is stretched between the fixed plates and welded to the cylindrical body of the cell.

When high pressure is applied to *both* sides of the cell, a slight deformation takes place, increasing tension in the sensing diaphragm. See Figure 4-5.

Figure 4-5. Static Pressure Effect on the δ -Cell Sensor.

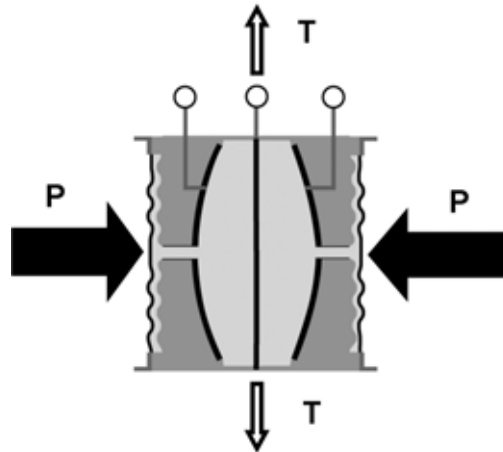

This increase in tension causes a reduction in transmitter output; as static pressure increases, output for any given differential decreases. In other words, as static pressure increases, a slightly higher differential pressure is required to move the sensing diaphragm a given amount. This static pressure effect is repeatable and linear, because it is within the realm governed by Hooke's Law, which states that a body acted upon by an external force will deform linearly, proportional to the stress, so long as a certain limit is not exceeded.

High static pressure causes a systematic span shift in the transmitter. Because static pressure always acts to reduce span and is linear, it is easy to correct the effect during calibration by performing a sensor trim. Table 4-2 shows the amount of systematic span shift for Range Codes 3 through 8.

Table 4-2. Systematic Span Shift

Range Code	316L SST	Alloy C-276
3	-1.75%	-1.0%
4	-0.90% ⁽¹⁾	-0.60%
5	-0.80% ⁽¹⁾	-0.70%
6	-1.50% ⁽¹⁾	-1.45%
7	-1.00% ⁽¹⁾	-1.05%
8	-0.65%	-0.65%

⁽¹⁾ Applies also to Rosemount 1151HP.

Correction for systematic error is made by simply calculating a correction factor for the high trim and low trim and inputting this correction into the transmitter.

To correct for systematic error due to static line pressure, use the following formulas to determine a corrected value for Low Trim and High Trim.

Low Trim (LT) = LRV + S (LRV) P

Where LT = Corrected Low Trim Value at Atmosphere
LRV = Lower Range Value at Pressure P
S = Span Shift from Table 4-2
P = Static Line Pressure

High Trim (HT) = URV + S (URV) P

Where HT = Corrected High Trim Value at Atmosphere
URV = Upper Range Value at Pressure P
S = Span shift from Table 4-2
P = Static Line Pressure

Example 1

A Rosemount 1151DP Range 4 transmitter is to be calibrated 0–90 inH₂O and used in an application where static line pressure is 1,200 psi.

Looking at Table 4-2 you see the Range 4 span is reduced by 0.90% per 1,000 psig. At 1,200 psi the span would be reduced by 1.08 percent.
 $0.009 \times 1.2 = 1.08\%$

Analog Electronics

There are two ways to calibrate an analog transmitter for this application. One method is to increase the pressure when adjusting the span. Another method is to apply the span pressure and increase the mA output.

1. Apply 0 inH₂O pressure and adjust the output to 4mA. then apply 90.97 inH₂O pressure and adjust the output to 20 mA.
 $90 \text{ inH}_2\text{O} \times 1.08\% = 0.97 \text{ inH}_2\text{O}$
 $90 \text{ inH}_2\text{O} \pm 0.97 \text{ inH}_2\text{O} = 89.03 \text{ inH}_2\text{O}$
2. Apply 0 inH₂O pressure and adjust the output to 4mA. then apply 90 inH₂O pressure and adjust the output to 20.173 mA.
 $16 \text{ mA} \times 1.08\% = 0.173 \text{ mA}$

Smart Electronics

There are also two ways to calibrate a smart transmitter for the above mentioned application. One way is to rerange the transmitter; the other way is to perform a sensor trim.

1. Using a Field Communicator, configure the range points to 0–89.03 inH₂O.
2. Using a Field Communicator, perform a sensor trim. Select Hi Val and apply 90 inH₂O pressure. When the communicator asks what pressure you applied enter 89.03 inH₂O. Set the range points to 0–90 inH₂O.

Example 2

A Rosemount 1151HP Range 5 transmitter with Alloy C-276 diaphragms is to be calibrated at 0–220 inH₂O and used in an application where the static line pressure is 2,300 psi.

Looking at Table 4-2 we see the Range 5 with Alloy C-276 diaphragms span is reduced by 0.70 percent per 1,000 psig. At 2,300 psi the span would be reduced by 1.61 percent.
 $0.007 \times 2.3 = 1.61\%$

Analog Electronics

Once again, there are two ways to calibrate an analog transmitter for this application. One method is to increase the pressure when adjusting the span. Another method is to apply the span pressure and increase the mA output.

1. Apply 0 inH₂O pressure and adjust the output to 4mA. then apply 223.54 inH₂O pressure and adjust the output to 20 mA.
 $220 \text{ inH}_2\text{O} \times 1.61\% = 3.54 \text{ inH}_2\text{O}$
 $220 \text{ inH}_2\text{O} \pm 3.54 \text{ inH}_2\text{O} = 216.46 \text{ inH}_2\text{O}$
2. Apply 0 inH₂O pressure and adjust the output to 4mA. then apply 220 inH₂O pressure and adjust the output to 20.257 mA.
 $16 \text{ mA} \times 1.61\% = .257 \text{ mA}$

Smart Electronics

There are also two ways to calibrate a smart transmitter for this application. One method is to rerange the transmitter. The other method is to perform a sensor trim.

1. Set the range points to 0–223.54 inH₂O by using the Field communicator.
2. Using the Field communicator, perform a Sensor Trim. Select Hi Val, and apply 216.96 inH₂O pressure. When the communicator asks what pressure was applied, enter 216.96 inH₂O. Set the range points to 0–220 inH₂O.

Digital to Analog Converter Trim**Deciding Whether to Trim the D/A Converter**

After the microprocessor conditions the sensor signals, it outputs a digital word. The digital-to-analog (D/A) output circuitry converts the word to an analog signal for the 4–20 mA communications line. It may be necessary to check and trim this circuitry after a period of time. The 4–20 mA output trim function can also be used to make adjustments to allow for peculiarities of a particular readout device in the loop.

To determine whether the output must be trimmed, connect the HART-based communicator and a precision milliammeter capable of reading ± 1 micromole in the loop as shown in Figure 4-3.

Next, perform a loop test as described on page 3-6. Follow the loop test procedure and set the transmitter to a 4 mA output. Then check the ammeter. The reading should be within $\pm 3 \mu\text{A}$ of 4 mA.

Then set the transmitter to a 20 mA output and check the milliammeter. The reading should be within $\pm 3 \mu\text{A}$ of 20 mA. The output should be trimmed if the values on the meter exceed this tolerance range.

When trimming the output, adjustments are made to the output circuitry. The appropriate shift will be made for all intermediate points between 4 and 20 mA.

The communicator will allow the D/A converter to be trimmed by using a current meter or voltage meter. When using a current meter, follow the sequence outlined in **4–20 mA Analog Output Trim**. When using a voltage meter or a meter whose display does not read out in 4–20 mA, follow the sequence outlined under **4–20 mA Analog Output Trim Using Other Scale**.

It may be necessary to calibrate the current output circuitry after a period of time and use. The 4–20 mA output trim function can also be used to make adjustments to allow for peculiarities of a particular readout device in the loop.

4–20 mA Analog Output Trim

HART Comm. Fast Key Sequence	1, 2, 3, 2, 1
-------------------------------------	---------------

A 4–20 mA output trim adjusts the transmitter milliampere output to match a plant’s current standard. Use this procedure when trimming the converter using a current meter.

4–20 mA Analog Output Trim Using Other Scale

HART Comm. Fast Key Sequence	1, 2, 3, 2, 2
-------------------------------------	---------------

To trim the output using a voltage or other meter, connect the meter across a resistor in the loop. For best accuracy, use a precision resistor. The scaling function may be used if the meter displays other units, such as 0–100%.

NOTE

If a resistor is added to the loop, before proceeding, ensure that the power supply is sufficient to power the transmitter to a 20 mA output with the additional loop resistance.

ANALOG CALIBRATION

Calibration Overview

Calibration of the Rosemount 1151 Analog Pressure Transmitter is simplified by its compact and explosion-proof design, external span and zero adjustments, separate compartments for electronics and wiring, and weatherproof construction. Descriptions of span, linearity, zero adjustments, and damping follow.

Figure 4-6. Output Trim

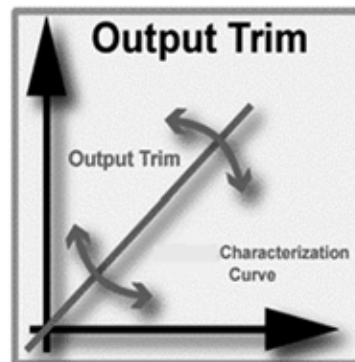

Quick Calibration Procedure (for E and G Electronics)

The following Quick Calibration Procedures are for those users who are already familiar with the Rosemount 1151 Analog.

NOTE

The zero and span adjustments are interactive. For applications requiring large elevated or suppressed values, refer to Elevated or Suppressed Zeros on page 3-7.

Rosemount 1151

1. Apply 4 mA-point pressure and turn zero screw to output 4 mA.
2. Apply 20 mA-point pressure.
3. Subtract actual output from desired output.
4. Divide difference by 3.
5. Turn span screw above or below desired output by value in Step 4.
6. Repeat Steps 1 through 5 until calibrated.

Quick Calibration Procedure (For L and M Electronics)

1. Apply 1 V dc-point pressure for M electronics (0.8 V dc for L electronics) and turn zero screw to output 1 V dc (0.8 V dc for L electronics).
2. Apply 5 V dc-point pressure (M electronics) or 3.2 V dc (L electronics).
3. Subtract actual output from desired output.
4. Divide difference by 3.
5. Turn span screw above or below desired output by value in Step 4.
6. Repeat Steps 1 through 5 until calibrated.

Example for a Rosemount 1151 Analog DP Range 4: For a desired calibration of 0 to 100 inH₂O, use the following procedure:

1. Adjust the zero. With zero input applied to the transmitter, turn the zero adjustment screw until the transmitter reads 4 mA.
2. Adjust the span. Apply 100 inH₂O to the transmitter high side connection. Turn the span adjustment screw until the transmitter output reads approximately 20 mA.
3. Release the input pressure and readjust the zero output to read 4 mA ± 0.032 mA.
4. Re-apply 100 inH₂O to the transmitter. If the output reading is greater than 20 mA, divide the difference by 3, and subtract the result from 20 mA. Adjust the 100% output to this value.

If the output reading is less than 20 mA, divide the difference by 3 and add the result to 20 mA. Adjust the 100% output to this value.

Example: The full scale transmitter output is 20.100 mA. Dividing 0.100 by 3.0 gives the product 0.033. Subtracting the product 0.033 from 20.00 mA gives the difference 19.967 mA. Adjust the 100% output to this value.

5. Release input pressure and readjust the zero.
6. Apply 100% input and repeat Steps 3 through 5 if the full scale output is not 20 ± 0.032 mA.

NOTE

Under operating conditions that subject the transmitter to temperature extremes or significant vibration, mechanical backlash may occur in the zero and span adjustment screws. To improve the stability of zero and span settings in these circumstances, back off the adjustment screws slightly after final adjustment to break contact between the potentiometer blades and the adjustment screw slot surfaces.

Data Flow with Calibration Options

Figure 4-7 illustrates the Rosemount 1151 Analog Transmitter data flow with calibration tasks.

Figure 4-7. Rosemount 1151
Transmitter Data Flow with
Calibration Options.

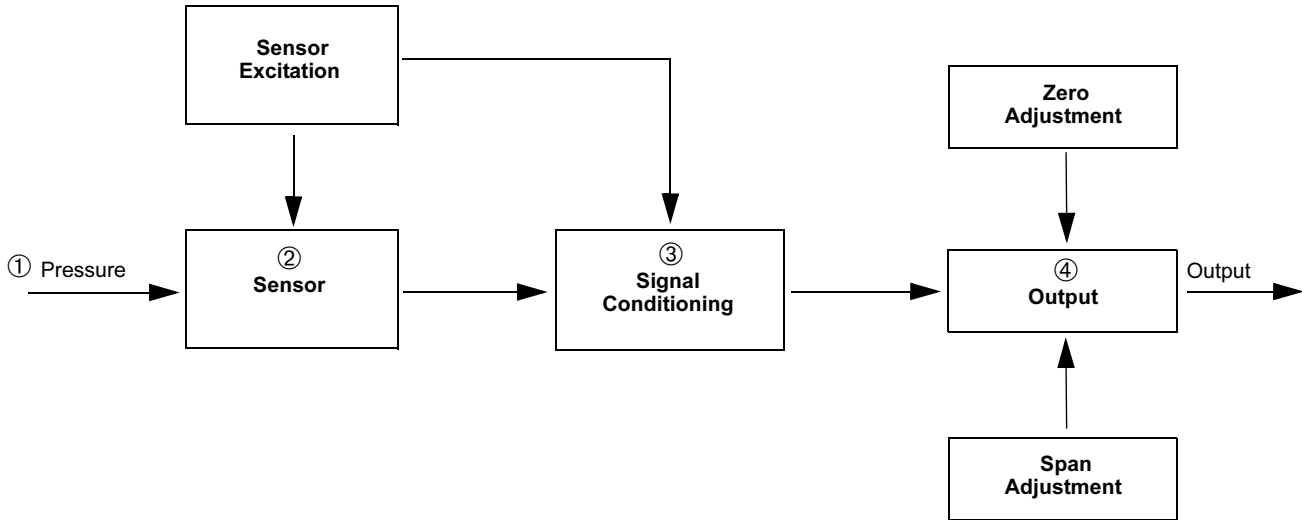

This data flow can be summarized in four major steps:

1. Pressure is applied to the sensor.
2. A change in pressure is measured by a change in the sensor output.
3. The sensor signal is conditioned for various parameters.
4. The conditioned signal is converted to an appropriate analog output.

Span Adjustment Range

The span on a Rosemount 1151 Analog with E and G output options is continuously adjustable to allow calibration anywhere between maximum span and one-sixth of maximum span. For example, the span on a Range 4 transmitter can be adjusted between 25 and 150 inH₂O (6.2 and 37.2 kPa).

Zero Adjustment Range

The zero on a Rosemount 1151 Analog with the E or G output options can be adjusted for up to 500% suppression or 600% elevation. See Figure 4-8.

Figure 4-8. Zero Adjustment Range.

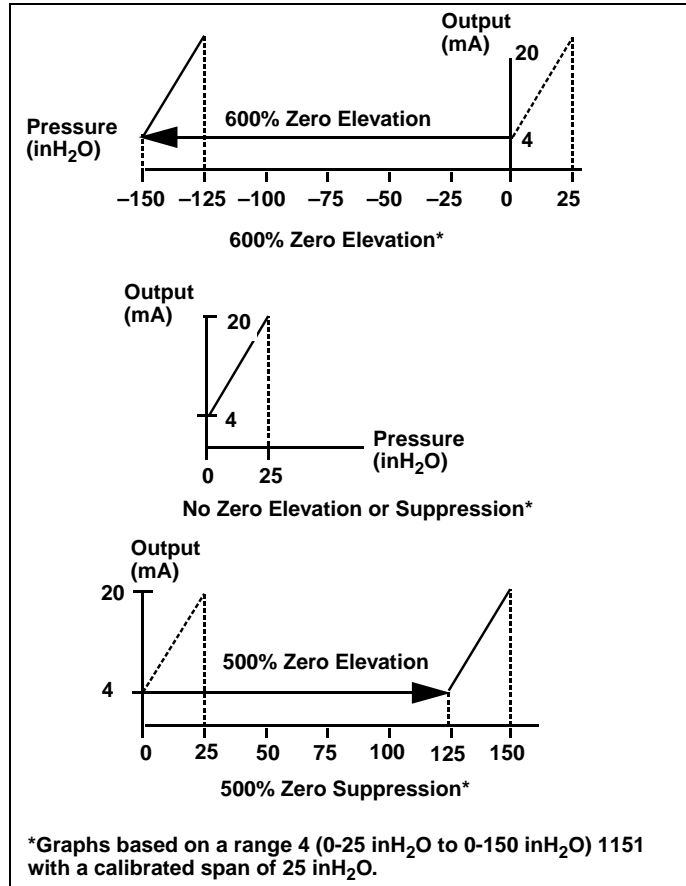

The zero may be elevated or suppressed to these extremes with the limitation that no pressure within the calibrated range exceeds the full-range pressure limit. For example, a Range 4 transmitter cannot be calibrated for 100 to 200 inH₂O (24.8 to 49.7 kPa) (only 100% zero suppression) because 200 inH₂O exceeds the 150 inH₂O full-range pressure limit of a Range 4.

To make large elevation or suppression adjustments, it is necessary to move the jumper on the component side of the amplifier board. Figure 4-9 on page -15 shows elevation and suppression jumper settings. The jumper has three positions. The middle position allows normal levels of elevation or suppression. For larger adjustments, move the jumper to the ELEVATE ZERO (EZ) or SUPPRESS ZERO (SZ) as marked.

NOTE

Always make sure that the jumper is fully seated on its pins. If the jumper has not been placed in any of the three positions, the amplifier board will provide normal levels of elevation or suppression. A slide switch replaces the jumper pin on some versions of the amplifier board.

Figure 4-9. Elevation and Suppression Jumper Settings.

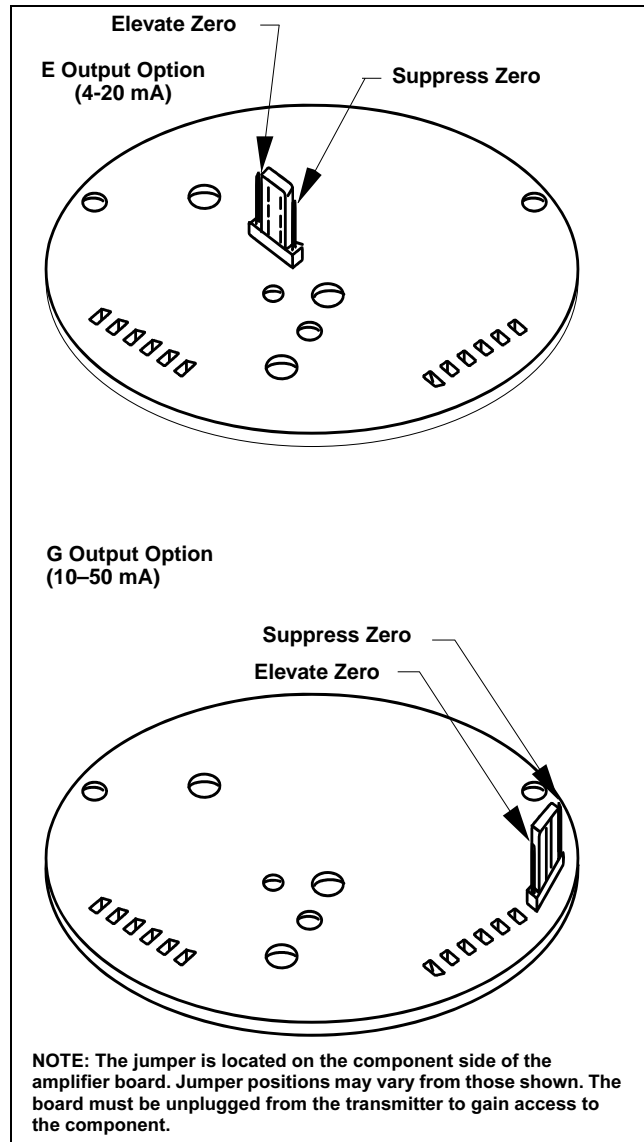

Zero and Span Adjustment

The zero and span adjustment screws are accessible externally behind the nameplate on the terminal side of the electronics housing. See Figure 4-10. The output of the transmitter increases with clockwise rotation of the adjustment screws. The zero adjustment screw and ELEVATE ZERO/SUPPRESS ZERO jumper do not affect the span. Span adjustment, however, does affect zero. This effect is minimized with zero-based spans. Therefore, when calibrations having elevated or suppressed zeros are made, it is easier to make a zero-based calibration and achieve the required elevation or suppression by adjusting the zero adjustment screw (and ELEVATE ZERO/SUPPRESS ZERO jumper as required).

A degree of mechanical backlash is present in the zero and span adjustments, so there will be a dead band when the direction of adjustment is changed. Because of the backlash, the simplest procedure is to purposely overshoot a larger amount before reversing the direction of the adjustment.

Figure 4-10. Zero and Span Adjustment Screws.

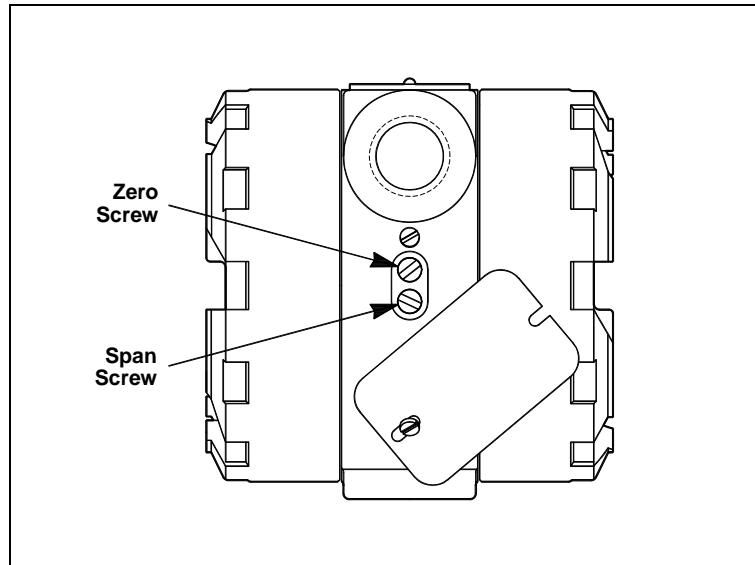

Elevated or Suppressed Zeros

Non-zero-based calibrations are termed as having “elevated” or “suppressed” zeros. Calibrations that have a lower calibrated value below zero are termed elevated. Compound ranges are included in this category. Calibrations that have a lower calibrated value above zero are termed suppressed.

The easiest way to calibrate transmitters with elevated or suppressed zeros is to perform a zero-based calibration and then elevate or suppress the zero by adjusting the zero adjustment screw.

Rosemount 1151 Analog DP Range 4 Suppression Example: For a desired calibration of 20 to 120 inH₂O (4.9 to 29.8 kPa), proceed as follows:

1. Calibrate the transmitter to 0 to 100 inH₂O (0 to 24.8 kPa) as described in the zero and span adjustment information.
2. Apply 20 inH₂O (4.9 kPa) to the high side process connection, and adjust the zero until the transmitter output reads 4 mA.

Do not use the span adjustment.

Rosemount 1151 Analog DP Range 4 Elevation Example: For a calibration of -120 to -20 inH₂O (-29.8 to -4.9 kPa), proceed as follows:

1. Calibrate the transmitter to 0 to 100 inH₂O (0 to 24.8 kPa) as described in the zero and span adjustment information.
2. Apply 120 inH₂O (29.8 kPa) to the low side process connection, and adjust the zero until the transmitter output reads 4 mA.

Do not use the span adjustment.

NOTE

For large amounts of elevation or suppression, it may be necessary to reposition the ELEVATE/SUPPRESS ZERO jumper. To do this, remove the amplifier board, and move the jumper to the ELEVATE or SUPPRESS position as required. See Figure 4-9 on page -15.

Linearity Adjustment

In addition to the span and zero adjustments, a linearity adjustment screw (marked LIN) is located on the solder side of the amplifier board. See Figure 4-11. This is a factory calibration adjusted for optimum performance over the calibrated range of the instrument and normally is not readjusted in the field. The user may, however, maximize linearity over a particular range using the following procedure:

1. Apply mid-range pressure and note the error between the theoretical and actual output signal.
2. Apply full-scale pressure. Multiply the error noted in Step 1 by six and then that product by the Range Down Factor, which is calculated as shown below:

$$\text{Range Down Factor} = \frac{\text{Maximum Allowable Span}}{\text{Calibrated Span}}$$

Add this result to the full-scale output (for negative errors), or subtract the result from the full-scale output (for positive errors) by turning the linearity adjustment screw.

Example: At 4 to 1 Range Down Factor, the mid-scale point is low by 0.05 mA. Therefore, turn the linearity adjustment screw until full-scale output increases by $(0.05 \text{ mA} \times 6 \times 4) = 1.2 \text{ mA}$.

3. Readjust the zero and span.

Figure 4-11. Damping and Linearity Adjustment Screws.

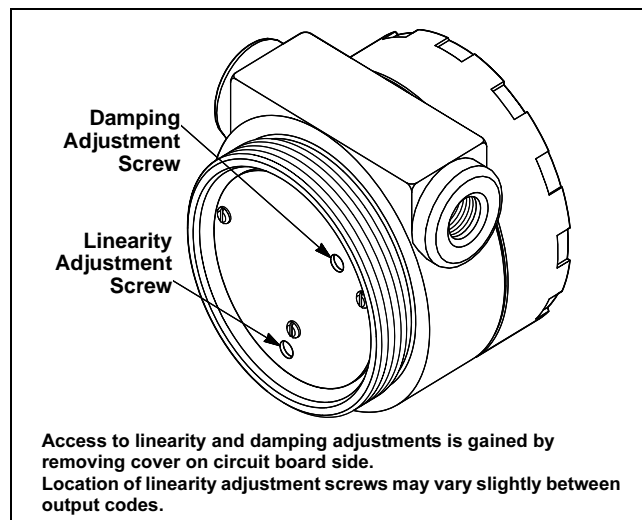

Damping Adjustment

The amplifier boards for output options E and G are designed to permit damping of rapid pulsations in the pressure source through adjustment of the damping screw shown in Figure 4-11 on page -17. The adjustment is marked DAMP on the solder side of the amplifier board.

The settings available provide time constant values between 0.2 and 1.66 seconds. The instrument is calibrated and shipped with this control set at the counterclockwise stop (0.2 second time constant). It is recommended that the shortest possible time constant setting be selected. Since the transmitter calibration is not influenced by the time constant setting, the damping may be adjusted with the transmitter connected to the process. Turn the damping control clockwise until the desired damping is obtained.

NOTE

The adjustment screw has positive stops at both ends. Forcing it beyond the stops may cause permanent damage.

Static Pressure Span Correction Factor

High static pressure causes a systematic span shift in the transmitter. It is linear and easily correctable during calibration. Table 4-3 shows the amount of span shift for range codes 3 through 8.

Table 4-3. Rosemount 1151 Analog DP/HP Span Shift.

Range Code	Span Shift % Input Per 1,000 psi	
	316L SST	Alloy C-276
3	-1.75%	-1.00%
4	-0.87%	-0.60%
5	-0.81%	-0.70%
6	-1.45%	-1.45%
7	-1.05%	-1.05%
8	-0.55%	-0.55%

The following examples illustrate a compensation method of accounting for the span shift. For more complicated calibration conditions, contact your local Emerson Process Management representative.

Example 1 - Refer to Table 4-3: One method is to adjust the input and allow the transmitter output to remain at 20 mA. Use the following formula:

Corrected Input

$$= \text{Desired URV} + [(S \times \text{URV}) \times (P/1000)],$$

Where S = Value from Table 4-3, divided by 100.

To calibrate a Range 4 transmitter 0 to 150 inH₂O (0 to 37.2 kPa) and correct for 1,500 psi static line pressure, use the following correction:

Corrected Input

$$= 150 + [(-0.0087 \times 150) \times (1500/1000)]$$

$$= 148.04 \text{ inches}$$

With 148.04 inches applied as input at atmospheric pressure, set the transmitter to 20 mA. When the transmitter is exposed to 1,500 psi static line pressure, output will be 20 mA at 150 inches input.

Where computers or microprocessor receivers are used, the mathematical definitions used in the preceding tables can be used to automatically and continuously make the correction.

All transmitters should be rezeroed under line pressure to remove zero error.

Example 2 - Refer to Table 4-4: A Rosemount 1151 Analog DP Range 4 with a 4–20 mA output operating at 1,200 psi static pressure requires the output at 100% to be corrected to 20.168 mA. Therefore, the transmitter should be adjusted from 4–20.168 mA during calibration. After installation, and with both process inputs pressurized to 1,200 psi, readjust the zero to 4.000 mA to remove the small zero error.

Table 4-4. Rosemount 1151 Analog DP Static Pressure 4–20 mA Output Code E Corrected Output Calibration at 100% Input SST Isolators.

Static Pressure (psi)	Static Pressure (kPa)	Range 3	Range 4	Range 5
100	689	20.029	20.014	20.013
200	1379	20.057	20.028	20.026
300	2068	20.086	20.042	20.039
400	2758	20.114	20.056	20.052
500	3447	20.143	20.070	20.066
600	4137	20.171	20.084	20.079
700	4826	20.200	20.098	20.092
800	5516	20.228	20.112	20.104
900	6205	20.257	20.126	20.118
1000	6895	20.285	20.140	20.131
1100	7584	20.314	20.154	20.144
1200	8274	20.342	20.168	20.157
1300	8963	20.371	20.182	20.170
1400	9653	20.399	20.196	20.183
1500	10342	20.428	20.210	20.197
1600	11032	20.456	20.224	20.210
1700	11721	20.485	20.238	20.223
1800	12411	20.513	20.252	20.236
1900	13100	20.542	20.266	20.250
2000	13790	20.570	20.280	20.262

Example 3 - Refer to Table 4-5: The correction factor at 100% input shift for a Range 5 transmitter with a 4–20 mA output operating at 1,500 psi static pressure would be:

$$S = 0.131 \times 1.5 = 0.197 \text{ mA}$$

Therefore, the calibration for this transmitter would be from 4–20.197 mA.

Table 4-5. Output Correction Factors SST Isolators.

Range Code	E Output 4–20 mA	G Output 10–50 mA
3	S = 0.285 P	S = 0.712 P
4	S = 0.140 P	S = 0.350 P
5	S = 0.131 P	S = 0.327 P
6	S = 0.235 P	S = 0.588 P
7	S = 0.170 P	S = 0.425 P
8	S = 0.088 P	S = 0.220 P

NOTE

Correction factors apply to E and G outputs at 100% input (P = static pressure in 1,000 psi).

Section 5 Troubleshooting

Overview	page 5-1
Safety Messages	page 5-1
Smart Troubleshooting	page 5-3
Analog Troubleshooting	page 5-10

OVERVIEW

This section is set up into two parts: Smart and Analog.

Table 5-1 on page 5-3 provides summarized troubleshooting suggestions for the most common operating problems on Smart transmitters. Table 5-2 on page 5-10 provides similar troubleshooting suggestions for analog transmitters.

If you suspect a malfunction despite the absence of any diagnostic messages on the communicator display, follow the procedures described here to verify that transmitter hardware and process connections are in good working order. Always deal with the most likely and easiest-to-check conditions first.

SAFETY MESSAGES

Warnings (⚠)

Procedures and instructions in this section that raise potential safety issues are indicated by a warning symbol (⚠). Refer to the following warning messages before performing an operation preceded by this symbol.

⚠ WARNING

- Isolate a failed transmitter from its pressure source as soon as possible. Pressure that may be present could cause death or serious injury to personnel if the transmitter is disassembled or ruptures under pressure.
- Explosions can cause death or serious injury. Do not remove the instrument cover in explosive atmospheres when the circuit is alive.
- Explosions can cause death or serious injury. Do not break the housing seal in explosive environments. Breaking the housing seal invalidates the explosion-proof housing rating.
- Process leaks can cause death or serious injury. An incorrectly installed backup ring can destroy the o-ring and cause process leaks. Install the backup ring using the following procedure.
- Exposure to hazardous substances can cause death or serious injury. If a hazardous substance is identified, a Material Safety Data Sheet (MSDS), required by law to be available to people exposed to specific hazardous substances, must be included with the returned goods.
- Explosions can cause death or serious injury. Do not disassemble the glass in the meter cover in explosive atmospheres. Disassembling the glass in the meter cover invalidates the explosion-proof meter rating.

WARNING

- The following performance limitations may inhibit efficient or safe operation. Critical applications should have appropriate diagnostic and backup systems in place. Pressure transmitters contain an internal fill fluid. It is used to transmit the process pressure through the isolating diaphragms to the pressure sensing element. In rare cases, oil leak paths in oil-filled pressure transmitters can be created. Possible causes include physical damage to the isolator diaphragms, process fluid freezing, isolator corrosion due to an incompatible process fluid, etc. A transmitter with an oil fill fluid leak can continue to perform normally for a period of time. Sustained oil loss will eventually cause one or more of the operating parameters to exceed published specifications while a small drift in operating point output continues. Symptoms of advanced oil loss and other unrelated problems include:
 - Sustained drift rate in true zero and span or operating point output or both
 - Sluggish response to increasing or decreasing pressure or both
 - Limited output rate or very nonlinear output or both
 - Change in output process noise
 - Noticeable drift in operating point output
 - Abrupt increase in drift rate of true zero or span or both
 - Unstable output
 - Output saturated high or low

SMART TROUBLESHOOTING

Table 5-1. Troubleshooting Symptoms and Corrective Action.

Symptom	Potential Source	Corrective Action
Transmitter does not communicate with the HART Communicator	Loop Wiring	Check for a minimum of 250 Ω resistance between the power supply and the communicator connection. Check for adequate voltage to the transmitter. (If the communicator is connected and 250 Ω resistance is properly in the loop, then the loop requires a minimum of 17 volts to operate.) Check for intermittent shorts, open circuits, and multiple grounds. Specify the transmitter by tag number. See the display sequence below.
	I.S. Barrier	Refer to appropriate I.S. Barrier documentation.
High Output	Primary Element	Check for restrictions at primary element.
	Impulse Piping	Check for leaks or blockage. Ensure that blocking valves are fully open. Check for entrapped gas in liquid lines and for liquid in dry lines. Ensure that the density of fluid in impulse lines is unchanged. Check for sediment in transmitter process flanges.
	Power Supply	Check the power supply output voltage at the transmitter. It should be 12 to 45 V dc.
	Transmitter Electronics	Connect the HART Communicator and enter the XMTR TEST mode to determine any electronic failures. Make sure that post connectors are clean. If the electronics are still suspect, substitute new electronics.
	Sensing Element	The sensing element is not field repairable and must be replaced if found to be defective. See "Disassembly procedure" later in this section for instructions on disassembly. Check for obvious defects, such as a punctured isolating diaphragm or fill fluid loss, and contact your local Emerson Process Management representative.

Symptom	Potential Source	Corrective Action
Erratic Output	Loop Wiring	Check for adequate voltage to the transmitter. It should be 12 to 45 V dc with no load. Check for intermittent shorts, open circuits and multiple grounds. <div style="border: 1px solid black; padding: 10px; text-align: center;"> <p>⚠ CAUTION</p> <p>Do not use over 45 volts to check the loop, or damage to the transmitter electronics may result.</p> </div> Connect the HART Communicator and enter the LOOP TEST mode to generate signals of 4 mA, 20 mA, and user-selected values.
	Process Pulsation	Adjust the electronic damping with the HART Communicator.
	Transmitter Electronics	Connect the communicator and perform a transmitter test to determine any electronic failures. Make sure the post connectors are clean. If the electronics are still suspect, substitute new electronics.
	Impulse Piping	Check for entrapped gas in liquid lines and for liquid in dry lines.
Low Output or No Output	Primary Element	Check the insulation and condition of primary element. Note any changes in process fluid properties that may affect output.

Symptom	Potential Source	Corrective Action
	Loop Wiring	<p>Check for adequate voltage to the transmitter. It should be 12 to 45 V dc. Check the milliamp rating of the power supply against the total current being drawn for all transmitters being powered. Check for shorts and multiple grounds. Check for proper polarity at the signal terminal. Check loop impedance. Check whether the transmitter is in multidrop mode, thus locking the output at 4 mA. Connect the communicator and perform a loop test.</p> <div style="border: 1px solid black; padding: 5px; margin: 10px 0;"> <p style="text-align: center;">⚠ CAUTION</p> <p>Do not use over 45 volts to check the loop, or damage to the transmitter electronics may result.</p> </div> <p>Check wire insulation to detect possible shorts to ground.</p>
	Impulse Piping	<p>Ensure that the pressure connection is correct. Check for leaks or blockage. Check for entrapped gas in liquid lines. Check for sediment in the transmitter process flange. Ensure that blocking valves are fully open and that bypass valves are tightly closed. Ensure that density of the fluid in the impulse piping is unchanged.</p>
	Transmitter Electronics	<p>Connect the communicator and check the sensor limits to ensure calibration adjustments are within the sensor range. Connect the communicator and perform a transmitter test to determine electronics failure. Make sure the post connectors are clean. If the electronics are still suspect, substitute new electronics.</p>
	Sensing Element	<p>The sensing element is not field repairable and must be replaced if found to be defective. See "Disassembly procedure" later in this section for instructions on disassembly. Check for obvious defects, such as punctured isolating diaphragm or fill fluid loss, and contact your local Emerson Process Management representative.</p>
Transmitter Does Not Characterize Properly	Pressure Source/Correction	<p>Check for restrictions or leaks. Check for proper leveling or zeroing of the pressure source. Check weights/gauge to ensure proper pressure setting. Determine if the pressure source has sufficient accuracy. (The pressure source should be at least three times more accurate than the Rosemount 1151 Smart.)</p>
Transmitter Does Not Characterize Properly	mA Meter	Determine if the mA meter is functioning properly.
	Power Supply	<p>Check the power supply output voltage at transmitter. It should be 12 to 45 V dc with no load. Check for a minimum of 250 Ω resistance between the HART Communicator and the power supply.</p>
	Transmitter Electronics	<p>Connect the communicator and perform a transmitter test to determine any electronic failures. Make sure the post connectors are clean. If electronics are still suspect, substitute with new electronics.</p>
	Sensing Element	<p>The sensing element is not field repairable and must be replaced if found to be defective. See "Disassembly procedure" later in this section for instructions on disassembly. Check for obvious defects, such as punctured isolating diaphragm or fill fluid loss, and contact your local Emerson Process Management representative.</p>

Disassembly Procedure ⚠ Read the following information carefully before you disassemble a transmitter. General information concerning the process sensor body, electrical housing, and a procedure for their separation follow. Figure 5-1 shows an exploded view of the transmitter.

Figure 5-1. Rosemount 1151 Smart Pressure Transmitter Exploded View.

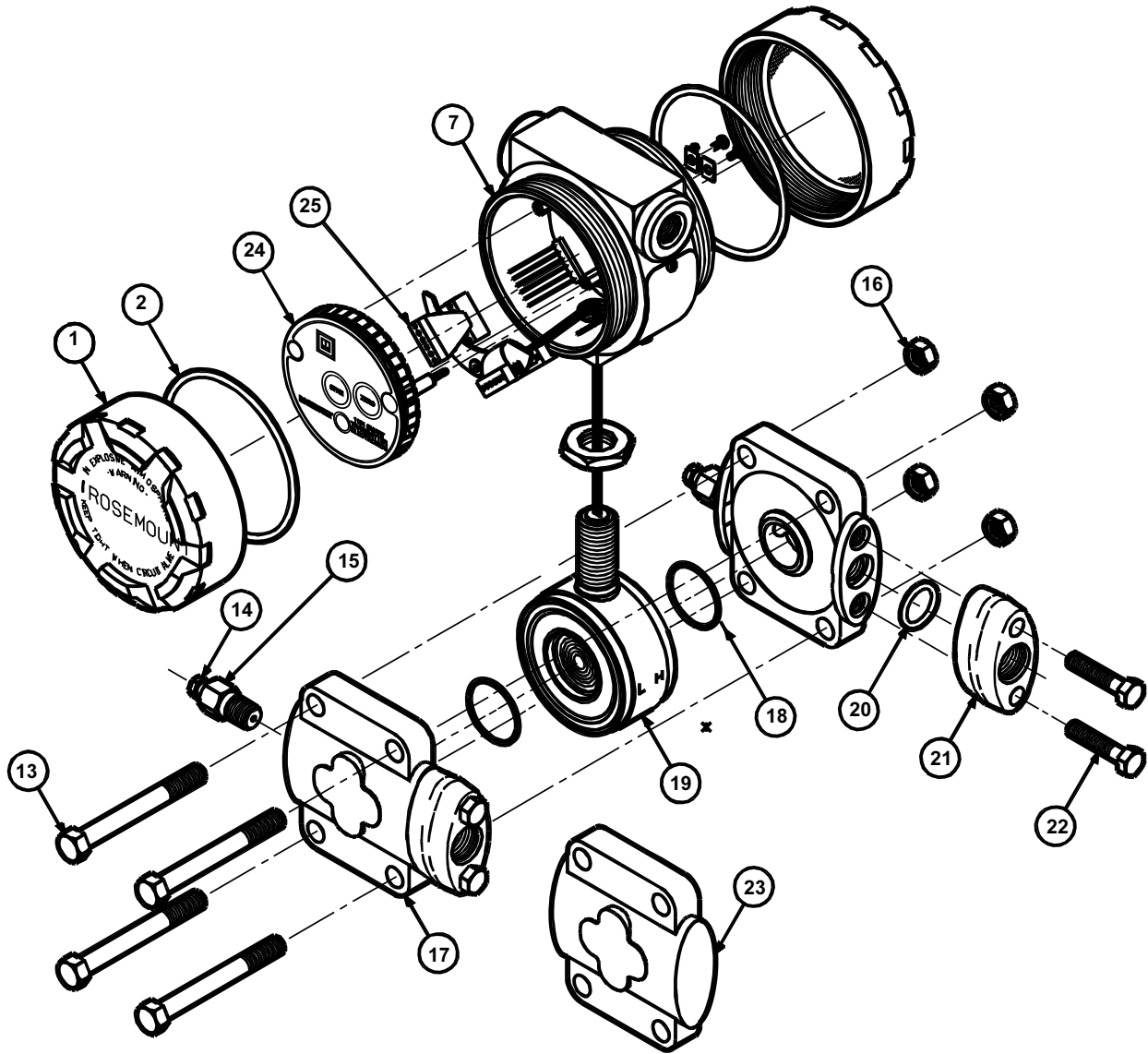

Process Sensor Body

Be aware of the following:

- The transmitter should be removed from service before disassembling the sensor body.
- Process flanges can be detached by removing the four large bolts.

CAUTION

Do not scratch, puncture, or depress the isolating diaphragms. Damaging the isolating diaphragms can inhibit transmitter performance.

- Isolating diaphragms may be cleaned with a soft rag, mild cleaning solution, and clear water rinse.

CAUTION

Do not use chlorine or acid solutions to clean the diaphragms. Damaging the isolating diaphragms can inhibit transmitter performance.

- Flange adapters and process flanges may be rotated or reversed for mounting convenience.

Electrical Housing

 Electrical connections are located in a compartment identified as TERMINAL SIDE on the nameplate. The signal and test terminals are accessible by unscrewing the cover on the terminal side. The terminals are permanently attached to the housing and must not be removed, or the housing seal between compartments will be broken.

To remove the smart electronics, refer to Appendix 6: Retrofitting the Rosemount 1151 Transmitter, and reverse the installation sequence described in steps 10 through 15.

Removing the Sensor from the Electrical Housing

1. Unscrew the cover on the field terminal side of the transmitter.
2. Disconnect the power source from the transmitter.
3. Remove the smart electronics and header board.
4. Loosen the lock nut.

CAUTION

Do not damage the isolating diaphragms when unscrewing the sensor module. Damaging the isolating diaphragms can inhibit transmitter performance.

5. The threaded connection has a sealing compound on it and will initially be tight. Unscrew the sensing module from the electronics housing, being careful not to damage the sensor leads. Carefully pull the header assembly board through the hole.

The sensing module is a welded assembly and cannot be further disassembled.

Reassembly Procedure

Follow these procedures carefully to ensure proper reassembly.

Preliminary Precaution

Inspect all O-rings and replace if necessary. Lightly grease with silicone oil to ensure a good seal. Use halocarbon grease for inert fill options.

Connecting the Electrical Housing to the Sensor

- ⚠ 1. Insert the header assembly board through the electronics housing.
2. Use a sealing compound (Loctite® 222—Small Screw Threadlocker) on the threads of the sensor module to ensure a watertight seal on the housing.
3. Screw the sensor module into the electrical housing making sure that at least five threads are engaged. Be careful not to damage or twist the sensor leads.
4. Align the sensor module with the high and low pressure sides oriented for convenient installation.
5. Tighten the lock nut.

Electrical Housing

The smart electronics and header board can easily be installed in the electrical housing. Steps 10 through 15 in Section 6 Retrofitting the Rosemount 1151 Transmitter describe this assembly.

⚠ CAUTION

An already characterized transmitter requires recharacterization whenever the sensor module or smart electronics are replaced. Failure to recharacterize can inhibit transmitter performance. (See Appendix 6: Retrofitting the Rosemount 1151 Transmitter.)

Process Sensor Body

All HP transmitters and GP Range 9 and 10 transmitters require metal backup rings to ensure O-ring integrity. Figure 5-2 illustrates the position and orientation of the metal backup rings. (Backup rings are not required on AP or DP transmitters or GP Range 3-8 transmitters.)

NOTE

Handle the backup ring carefully, as it is fragile. Examine the ring carefully. One side is beveled, while the other side is flat. The flat side appears more shiny when viewed from above.

1. Clean the sealing surfaces carefully.
2. Place the module on a flat surface, “H” side up.
3. Place the greased flange O-ring around the isolator and push it into the cavity.

Figure 5-2. Detail Showing Process O-ring and Backup Ring Installation of Module Seal for Rosemount 1151HP and GP Range 9 (GP Range 10 Requires Only One O-ring and Backup O-ring).

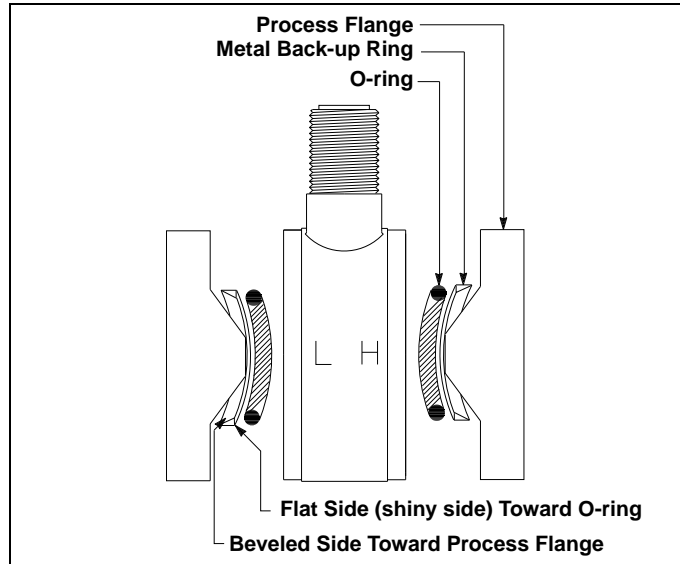

4. For all HP transmitters and GP transmitters Ranges 9 and 10, place the backup ring, shiny side down, on top of the O-ring. This places the flat side of the backup ring against the O-ring.
5. Carefully place the flange on top of the module, beveled side down so that the beveled flange surface mates with the beveled surface of the backup ring.
6. Keeping the flange and module together, turn them over so the “L” side is up. Repeat Steps 3 through 5. As before, the flat side of the backup ring must rest against the O-ring.
7. Insert the four flange bolts.
8. Tighten the nuts finger tight, making sure the flanges remain parallel. The transmitter may now be moved without disturbing the O-rings.
 - a. Tighten one bolt until the flanges seat.
 - b. Torque down the bolt diagonally across.
 - c. Torque down the first bolt.
 - d. Torque down the two remaining bolts.
 - e. Inspect the flange-to-sensor seating to be sure that the flanges are not cocked.
 - f. Check that all four bolts are tightened to approximately 33 ft.-lb (39 Nm).
9. Recalibrate the transmitter.

Optional Plug-in Meters

The optional indicating meters available for Rosemount 1151 transmitters are listed in Section A: Reference Information. Please be aware of the following information while assembling the meter assembly. Refer to Table A-11 on page A-23 for part references.

- The display may be rotated in 90-degree increments for convenient reading.
- ⚠ • If the display cover is removed for any reason, be sure the O-ring is in place between the cover and housing before reattachment. To maintain an explosion-proof condition, the glass in the meter cover should not be disassembled for any reason.

Sensor Module Checkout

The sensor module is not field repairable and must be replaced if found to be defective. If no obvious defect is observed (such as a punctured isolating diaphragm or fill fluid loss), the sensor module can be checked as follows.

1. Carefully pull the header assembly board off of the post connectors. Rotate the board 180 degrees about the axis formed by the connecting leads. The sensor module and electronics housing can remain attached for checkout.
2. Check internal diode loops, forward and reverse bias: one loop is on pins one and two, the other is on pins three and four. See Figure 5-3. Loop resistance values should be nearly equal.

NOTE

Do not touch the transmitter housing when checking resistances, or a faulty reading can result.

3. Check the resistance between the sensor module housing and pins one through four. This checks the resistance between both capacitor plates and the sensing diaphragm, which is grounded to the housing. This resistance should be greater than 10 MΩ.
4. Check the resistance between pin eight and the sensor module to ensure that the module is grounded. Resistance should be zero.

NOTE

The above procedure does not completely test the sensor module. If circuit board replacement does not correct the abnormal condition, and no other problems are obvious, replace the sensor module.

Figure 5-3. Header Board Connections.

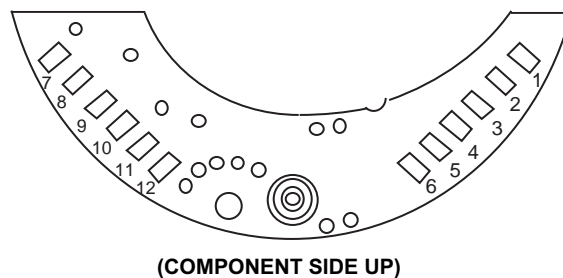

Rosemount 1151

ANALOG TROUBLESHOOTING

Hardware Diagnostics

If you suspect a malfunction, see Table 5-2 on page 5-10 to verify that transmitter hardware and process connections are in good working order. Under each of the five major symptoms, you will find specific suggestions for solving the problem. Always deal with the most likely and easiest to check conditions first.

⚠ WARNING

Isolate a failed transmitter from its pressure source as soon as possible. Pressure that may be present could cause death or serious injury to personnel if the transmitter is disassembled or ruptures under pressure.

Table 5-2. Troubleshooting Symptoms and Corrective Action.

Symptom	Potential Source	Corrective Action
High Output	Primary Element	Check for restrictions at primary element.
	Impulse Piping	Check for leaks or blockage. Ensure that blocking valves are fully open. Check for entrapped gas in liquid lines and for liquid in dry lines. Ensure that the density of fluid in impulse lines is unchanged. Check for sediment in transmitter process flanges.
	Power Supply	Check the power supply output voltage at the transmitter.
	Transmitter electronics	Make sure that post connectors are clean. If the electronics are still suspect, substitute new electronics.
	Sensing Element	The sensing element is not field repairable and must be replaced if found to be defective. See "Transmitter Disassembly" later in this section for instructions on disassembly. Check for obvious defects, such as punctured isolating diaphragm or fill fluid loss, and contact your local Emerson Process Management representative.
Erratic Output	Loop Wiring	Check for adequate voltage to the transmitter. Check for intermittent shorts, open circuits and multiple grounds.
		<p style="text-align: center;">⚠ CAUTION</p> <p style="text-align: center;">Do not use higher than the specified voltage to check the loop, or damage to the transmitter electronics may result.</p>
	Process Pulsation	Adjust Damping
	Transmitter Electronics	Make sure the post connectors are clean. If the electronics are still suspect, substitute new electronics.
	Impulse Piping	Check for entrapped gas in liquid lines and for liquid in dry lines.

Symptom	Potential Source	Corrective Action
Low Output or No Output	Primary Element	Check the insulation and condition of primary element. Note any changes in process fluid properties that may affect output.
	Loop Wiring	<p>Check for adequate voltage to the transmitter. Check the milliamp rating of the power supply against the total current being drawn for all transmitters being powered. Check for shorts and multiple grounds. Check for proper polarity at the signal terminal. Check loop impedance. Check whether the transmitter is in multidrop mode, thus locking the output at 4 mA.</p> <div style="border: 1px solid black; padding: 5px; margin: 10px auto; width: fit-content;"> <p style="text-align: center;">⚠ CAUTION</p> <p style="text-align: center;">Do not use higher than the specified voltage to check the loop, or damage to the transmitter electronics may result.</p> </div> <p>Check wire insulation to detect possible shorts to ground.</p>
	Impulse Piping	<p>Ensure that the pressure connection is correct. Check for leaks or blockage. Check for entrapped gas in liquid lines. Check for sediment in the transmitter process flange. Ensure that blocking valves are fully open and that bypass valves are tightly closed. Ensure that density of the fluid in the impulse piping is unchanged.</p>
	Sensing Element	<p>The sensing element is not field repairable and must be replaced if found to be defective. See "Transmitter Disassembly" later in this section for instructions on disassembly. Check for obvious defects, such as punctured isolating diaphragm or fill fluid loss, and contact your local Emerson Process Management representative.</p>
Transmitter Does Not Calibrate Properly	Pressure Source/Correction	<p>Check for restrictions or leaks. Check for proper leveling or zeroing of the pressure source. Check weights/gauge to ensure proper pressure setting. Determine if the pressure source has sufficient accuracy.</p>
	Meter	Determine if the meter is functioning properly.
	Power Supply	Check the power supply output voltage at transmitter.
	Transmitter Electronics	<p>Make sure the post connectors are clean. If electronics are still suspect, substitute with new electronics.</p>
	Sensing Element	<p>The sensing element is not field repairable and must be replaced if found to be defective. See "Transmitter Disassembly" later in this section for instructions on disassembly. Check for obvious defects, such as punctured isolating diaphragm or fill fluid loss, and contact your local Emerson Process Management representative.</p>

Transmitter Disassembly

Read the following information carefully before you disassemble a transmitter. General information concerning the process sensor body, electrical housing, and a procedure for their separation follow. Figure 5-4 shows an exploded view of the transmitter.

WARNING

The following performance limitations may inhibit efficient or safe operation. Critical applications should have appropriate diagnostic and backup systems in place.

Pressure transmitters contain an internal fill fluid. It is used to transmit the process pressure through the isolating diaphragms to the pressure sensing element. In rare cases, oil leak paths in oil-filled pressure transmitters can be created. Possible causes include: physical damage to the isolator diaphragms, process fluid freezing, isolator corrosion due to an incompatible process fluid, etc.

A transmitter with an oil fill fluid leak can continue to perform normally for a period of time. Sustained oil loss will eventually cause one or more of the operating parameters to exceed published specifications while a small drift in operating point output continues. Symptoms of advanced oil loss and other unrelated problems include:

- Sustained drift rate in true zero and span or operating point output or both
- Sluggish response to increasing or decreasing pressure or both
- Limited output rate or very nonlinear output or both
- Change in output process noise
- Noticeable drift in operating point output
- Abrupt increase in drift rate of true zero or span or both
- Unstable output
- Output saturated high or low

WARNING

Explosion can cause death or serious injury. Do not remove the instrument cover in explosive atmospheres when the circuit is alive.

WARNING

Explosions can cause death or serious injury. Do not break the housing seal in explosive environments. Breaking the housing seal invalidates the explosion-proof housing rating.

Electrical connections are located in a compartment identified as **TERMINAL SIDE** on the nameplate. The signal and test terminals are accessible by unscrewing the cover on the terminal side. The terminals to the housing must not be removed, or the housing seal between compartments will be broken. (Not applicable to R1 Option.)

Process Sensor Body Removal

Be aware of the following guidelines:

- The transmitter should be removed from service before disassembling the sensor body.
- Process flanges can be detached by removing the four large bolts.

CAUTION

Do not scratch, puncture, or depress the isolating diaphragms. Damaging the isolating diaphragms can inhibit transmitter performance.

- Isolating diaphragms may be cleaned with a soft rag, mild cleaning solution, and clear water rinse.

CAUTION

Do not use chlorine or acid solutions to clean the diaphragms. Damaging the isolating diaphragms can inhibit transmitter performance.

- Flange adapters and process flanges may be rotated or reversed for mounting convenience.

Figure 5-4. Differential Pressure (DP) Transmitter Exploded View.

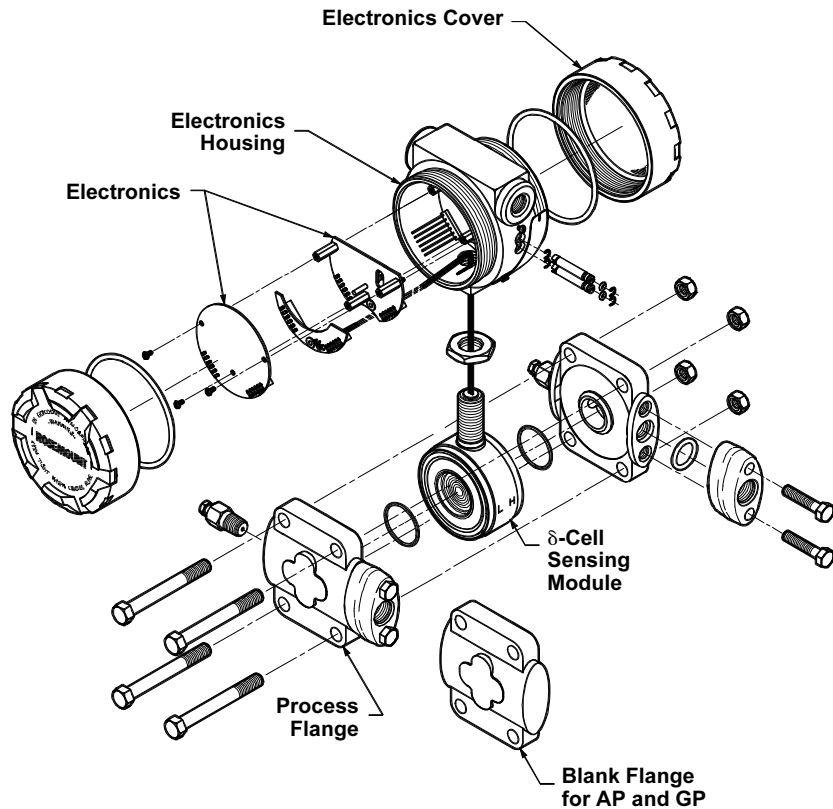

Removing the Sensor from the Electrical Housing

- Disconnect the power source from the transmitter.
- Unscrew the cover on the terminal side of the transmitter.
- Remove the screws and unplug the electronics; see Figure 5-5.
- Loosen the lock nut.
- Remove the standoffs.

CAUTION

Do not damage the isolating diaphragms when unscrewing the sensor module. Damaging the isolating diaphragms can inhibit transmitter performance.

1. Unscrew the sensing module from the electronics housing, being careful not to damage the sensor leads. Carefully pull the header assembly board through the hole. The threaded connection has a sealing compound on it and must be broken loose.

The sensing module is a welded assembly and cannot be further disassembled.

Figure 5-5. Removal of Electronics.

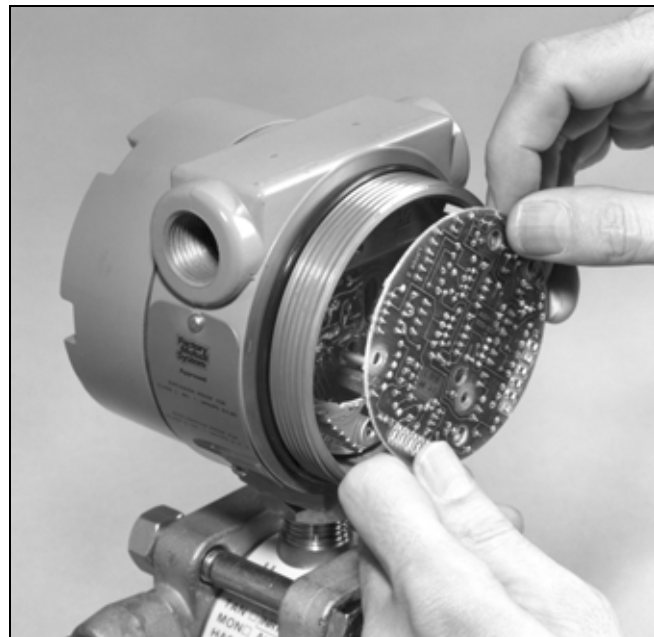

Sensor Module Checkout

The sensor module is not field repairable and must be replaced if found to be defective. If no obvious defect is observed (such as a punctured isolating diaphragm or fill fluid loss), the sensor module can be checked as follows.

1. Carefully pull the header assembly board off of the post connectors. Rotate the board 180 degrees about the axis formed by the connecting leads. The sensor module and electronics housing can remain attached for checkout.

NOTE

Do not touch the transmitter housing when checking resistances, or a faulty reading can result.

2. Check the resistance between the sensor module housing and pins one through four. This checks the resistance between both capacitor plates and the sensing diaphragm, which is grounded to the housing. This resistance should be greater than 10 MΩ.
3. Check the resistance between pin eight and the sensor module to ensure that the module is grounded. Resistance should be zero.

NOTE

The above procedure does not completely test the sensor module. If circuit board replacement does not correct the abnormal condition, and no other problems are obvious, replace the sensor module.

Figure 5-6. Header Board Connections.

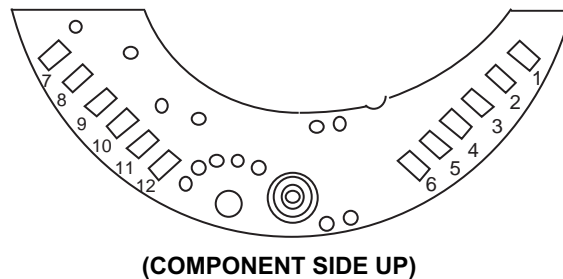

Reassembly Procedure

Follow these procedures carefully to ensure proper reassembly.

Preliminary Precaution

Inspect all O-rings and replace if necessary. Lightly grease with silicone oil to ensure a good seal. Use halocarbon grease for inert fill options.

WARNING

Explosions can cause death or serious injury. Both transmitter covers must be fully engaged to meet explosion-proof requirements.

Connecting the Electrical Housing to the Sensor

1. Insert the header assembly board through the electronics housing.
2. Use a sealing compound (Loctite® 222 - Small Screw Threadlocker) on the threads of the sensor module to ensure a watertight seal on the housing.
3. Screw the sensor module into the electrical housing making sure that the threads are fully engaged. Be careful not to damage or twist the sensor leads.
4. Align the sensor module with the high and low pressure sides oriented for convenient installation.
5. Tighten the lock nut.

Backup Ring and O-ring Installation

All HP transmitters and GP Range 9 and 0 transmitters require metal backup rings to ensure O-ring integrity. Figure 5-7 on page 5-16 illustrates the position and orientation of the metal backup rings. (Backup rings are not required on AP or DP transmitters or GP Range 3-8 transmitters.)

Figure 5-7. Detail Showing Process O-ring and Backup Ring Installation of Module Seal for Rosemount 1151HP and GP Range 9 (GP Range 0 Requires Only One O-ring and Backup O-ring).

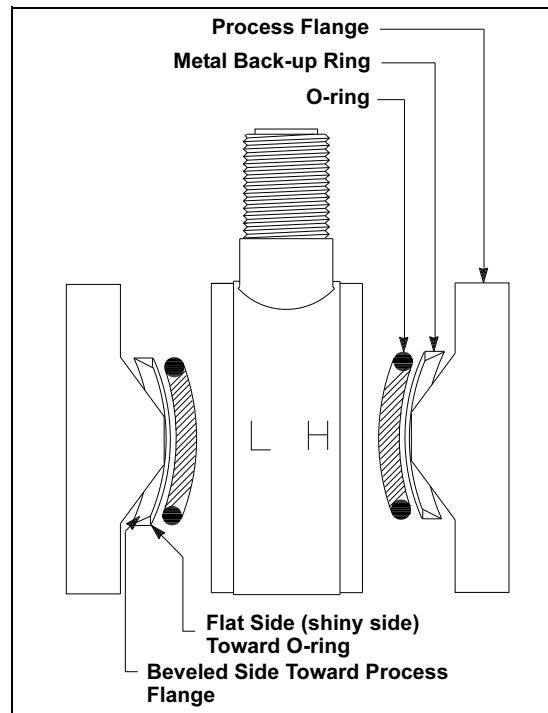

NOTE

Handle the backup ring carefully, as it is fragile. Examine the ring carefully. One side is beveled, while the other side is flat. The flat side appears more shiny when viewed from above.

1. Clean the sealing surfaces carefully.
2. Place the module on a flat surface, “H” side up.
3. Place the greased flange O-ring around the isolator and push it into the cavity.

⚠ WARNING

Process leaks can cause death or serious injury. An incorrectly installed backup ring can destroy the o-ring and cause process leaks. Install the backup ring using the following procedure.

4. For all HP transmitters and GP transmitters Ranges 9 and 0, place the backup ring, shiny side down, on top of the O-ring. This places the flat side of the backup ring against the O-ring.
5. Carefully place the flange on top of the module, beveled side down so that the beveled flange surface mates with the beveled surface of the backup ring.
6. Keeping the flange and module together, turn them over so the “L” side is up. Repeat Steps 3 through 5. As before, the flat side of the backup ring must rest against the O-ring.
7. Insert the four flange bolts.
8. Tighten the nuts finger tight, making sure the flanges remain parallel. The transmitter may now be moved without disturbing the O-rings.
 - a. Tighten one bolt until the flanges seat.
 - b. Torque down the bolt diagonally across.
 - c. Torque down the first bolt.
 - d. Torque down the two remaining bolts.
 - e. Inspect the flange-to-sensor seating to be sure that the flanges are not cocked.
 - f. Check that all four bolts are tightened to approximately 33 ft-lb (39 Nm).
9. Recalibrate the transmitter.

NOTE

If the Rosemount 1151 Range 3 transmitter sensor module serial number is below 2,900,000, it must be temperature cycled whenever changing or rebolting flanges.

Optional Plug-in Meters

The optional indicating meters available for Rosemount 1151 transmitters are listed in Appendix A: Reference Information. Please be aware of the following information while assembling the meter assembly. Refer to Table A-11 on page A-23 for part references.

- The meter may be rotated in 90-degree increments for convenient reading.

WARNING

Explosions can cause death or serious injury. Do not disassemble the glass in the meter cover in explosive atmospheres. Disassembling the glass in the meter cover invalidates the explosion-proof meter rating.

- If the meter cover is removed for any reason, be sure the O-ring is in place between the cover and housing before reattachment. To maintain an explosion-proof condition, the glass in the meter cover must not be disassembled for any reason.

Section 6 **Retrofitting the Rosemount 1151 Transmitter**

Overview	page 6-1
Safety Messages	page 6-1
Retrofitting Overview	page 6-2
Removing the Analog Electronics Assembly	page 6-2
Installing the Smart Retrofit Kit	page 6-10
Characterization	page 6-12

OVERVIEW

This section describes how the Rosemount Smart Retrofit Kit can be used to retrofit a Rosemount 1151AP, DP, GP, HP, or LT transmitter with 4-20 mA dc linear or square root output.

NOTE

The Rosemount 1151DR (Draft Range) Transmitter cannot be retrofitted with the 1151-0935-0001 Retrofit Kit. In addition, Rosemount 1151 transmitters with serial numbers below 10,000 and Rosemount 1151 AP Range Code 4 Transmitters with serial numbers between 1,318,500 and 1,690,000 may experience some degradation in performance from temperature effect if retrofitted. Therefore, retrofitting of these transmitters is not recommended.

SAFETY MESSAGES

Warnings (⚠)

Procedures and instructions in this section that raise potential safety issues are indicated by a warning symbol (⚠). Refer to the following warning messages before performing an operation preceded by this symbol.

⚠ WARNING

- Explosions can result in serious injury or death. Before connecting a communicator in an explosive atmosphere, make sure the instruments in the loop are installed in accordance with intrinsically safe or nonincendiary field wiring practices.
- Toxic processes can result in serious injury or death. Transmitter can contain residue process. Use appropriate safety precautions when opening drain vents or disconnecting a transmitter from a process.
- DO NOT attempt to loosen drain vent valves or disconnect the transmitter from the process without taking precautionary measures.
- Install and tighten all four process adapter bolts or drain vent valves before applying pressure.
- Both transmitter covers must be fully engaged to meet explosion-proof requirements.

RETROFITTING OVERVIEW

The procedure for retrofitting a transmitter is divided into three parts:

1. Removing the analog electronics assembly.
2. Installing the smart electronics kit.
3. Characterizing the retrofitted transmitter.

Two tools are required to remove the analog electronics and to install the smart electronics:

- Flat-bladed screwdriver
- 1/4-in. nut driver or wrench

The following equipment is needed to characterize the retrofitted transmitter:

- A HART Communicator
- An accurate pressure source, preferably 0.025% accuracy or better
- A 250 ohm resistor

The Smart Retrofit Kit, P/N 01151-0935-0001, contains the following items:

Quantity	Description
1	Smart electronic assembly
1	Electronics cover
1	Cover O-ring
2	Terminal eyelets
2	Board spacers
2	Standoffs

REMOVING THE ANALOG ELECTRONICS ASSEMBLY

CAUTION

Use proper earth grounding techniques when handling the smart electronics assembly. The smart electronics assembly is potentially sensitive to electric static discharge.

Confirm the output code of the Rosemount 1151 is analog (4-20 mA). It will have an "E" in the eighth character in the model number on the transmitter nameplate.

Example: (1151DP4 E 12M1)

The following steps describe how to remove the analog electronics assembly from transmitters with "E" output code for smart retrofitting. However, they can also be used as guidelines for retrofitting transmitters with "A" or "C" output codes. This process requires opening the electronics compartment on the circuit side of the transmitter and removing the amplifier or amplifier/squaring assembly, standoffs, and the calibration board.

NOTE

Numbers in parentheses indicate parts shown in Figure 6-1.

Figure 6-1. Rosemount 1151 Analog Electronics.

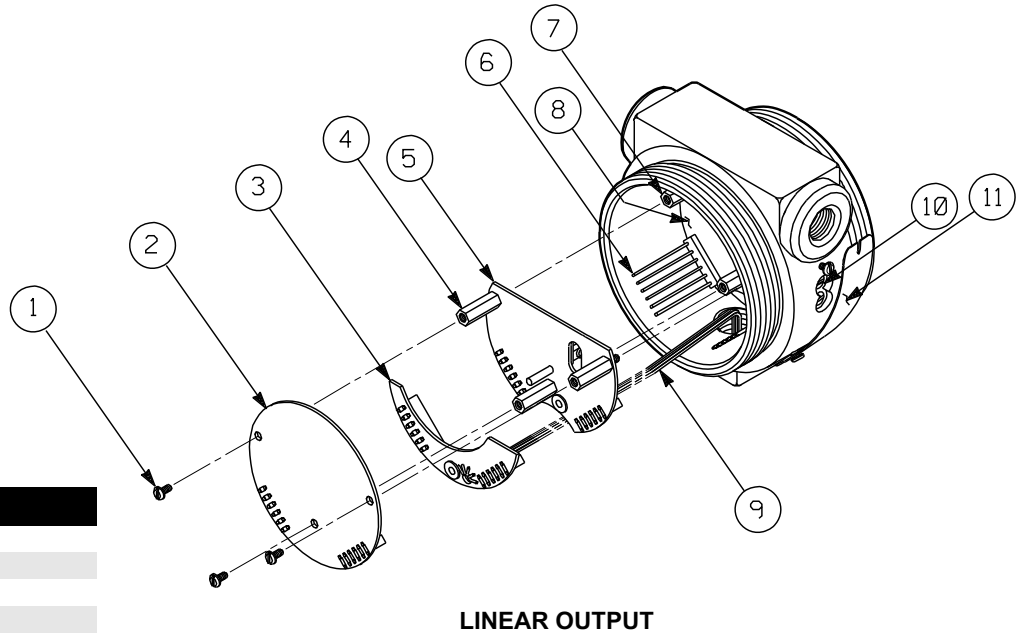

Ref. No.	Part Description
1	Retainer Screws (Linear)
2	Amplifier Board (Linear)
3	Header Board Assembly
4	Standoff Screws (Linear)
5	Calibration Board (Linear)
6	Bayonet Connector Pins
7	Standoff Screws (Linear)
8	Sensor Module Electronics
9	Wiring
10	Zero and Span Adjust Screws
11	Housing Cover

1. Ensure that power is removed from the transmitter before beginning the retrofit procedure.
- ⚠ 2. Remove the cover from the circuit side of the transmitter.
3. Remove the three retainer screws (1 or 12).

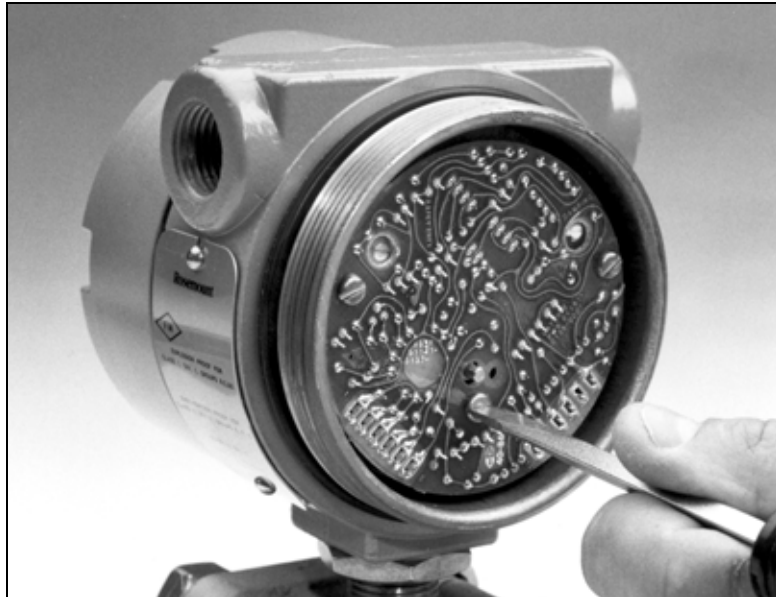

4. Pull the amplifier board (2) or amplifier/squaring assembly (13) directly off the bayonet connectors (6).

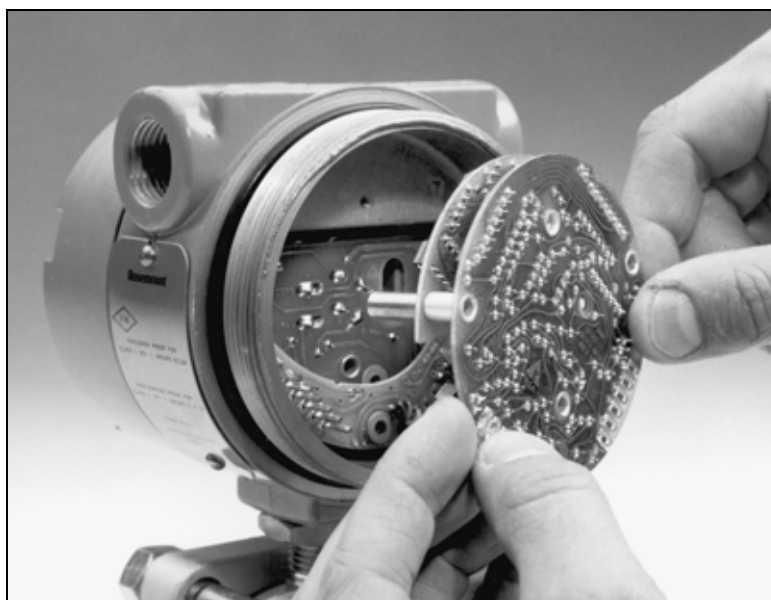

5. Pull the header board assembly (3) off the bayonet connectors. The header board must be reinserted. Do not cut the wires (9) or remove the header board.

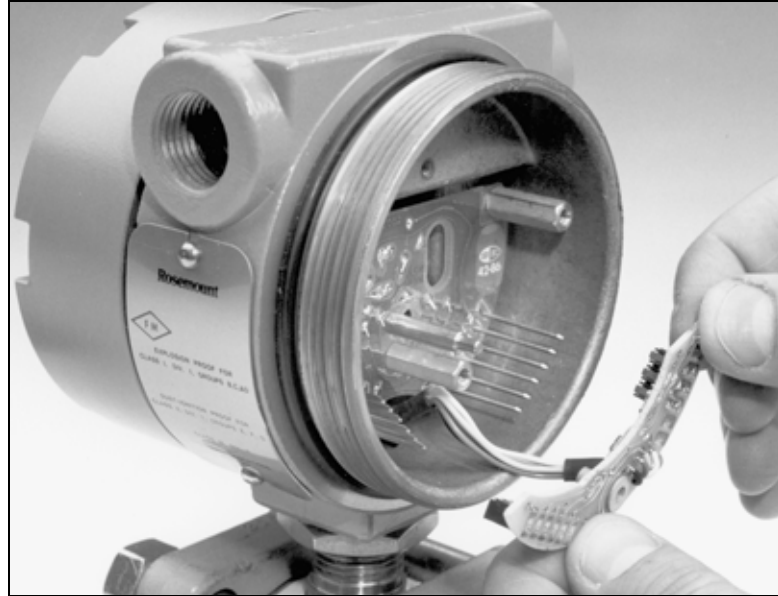

6. If the transmitter has linear output electronics, remove the three standoffs (4). Use a 1/4-in. nut driver or wrench.

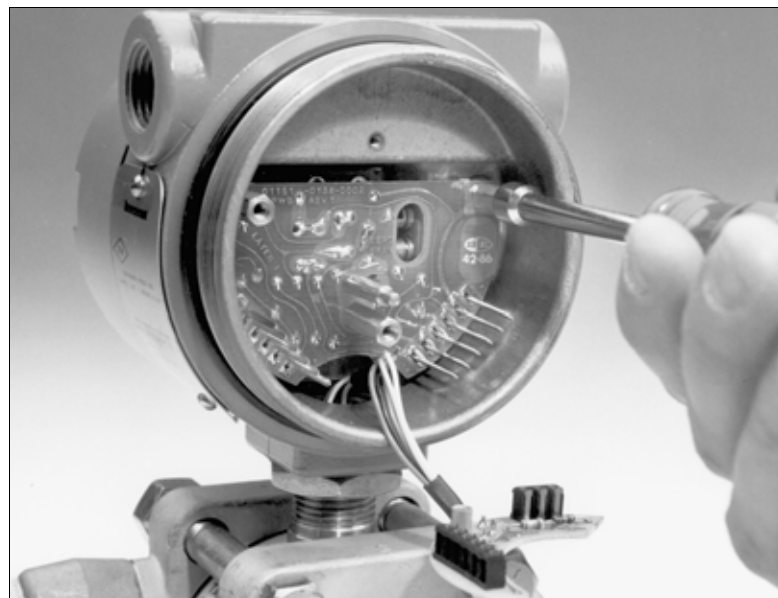

7. Align the zero and span adjust screws (10) so that the potentiometer blades are perpendicular to the board.

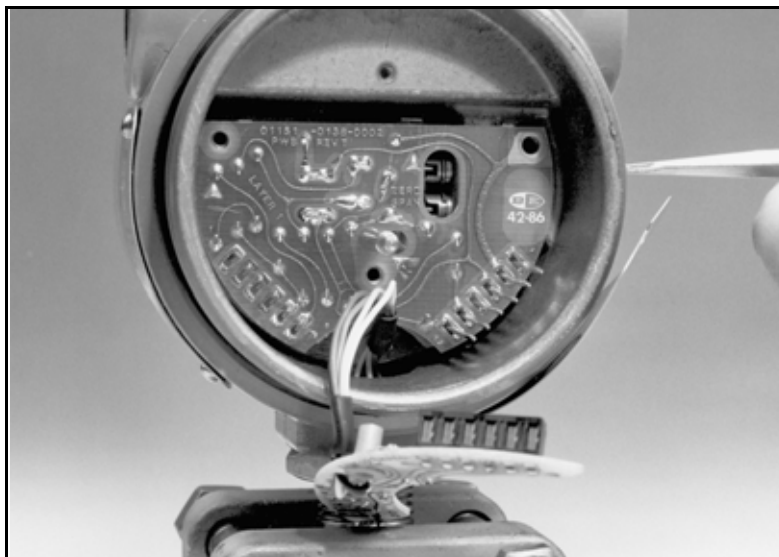

8. For linear output models, grip the calibration board (5) by the interface pin. (Removing the calibration board disables the conventional zero and span screws.)

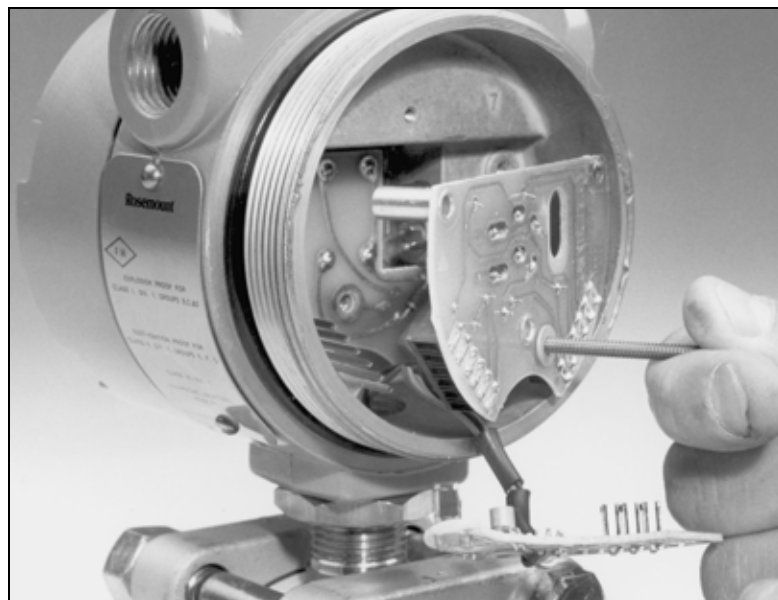
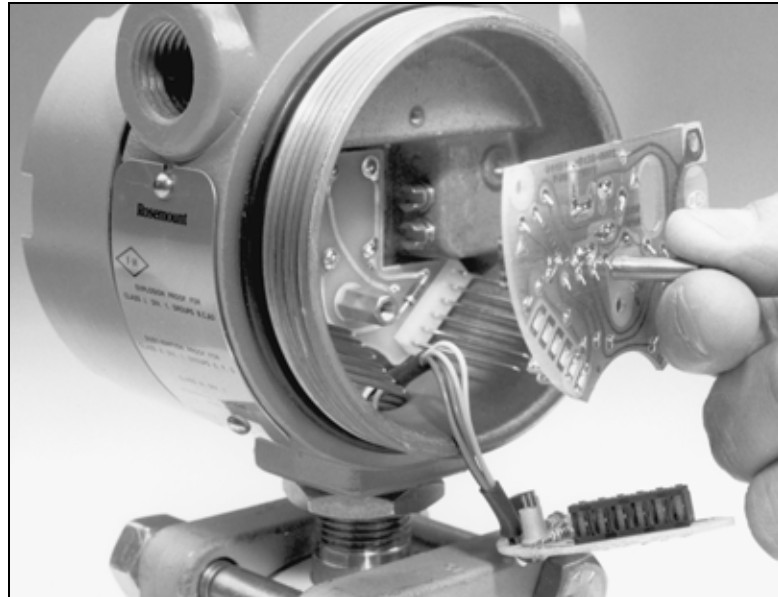

Insert the standoffs (7), if necessary. The transmitter is now ready to receive the plug-in smart electronics assembly.

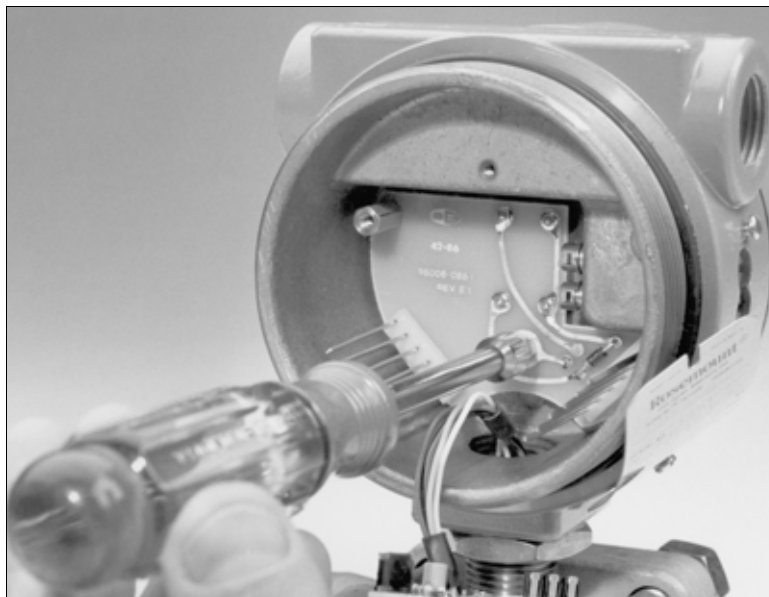

INSTALLING THE SMART RETROFIT KIT

Installing the smart retrofit electronics kit in the transmitter requires installing plastic spacers to accommodate the retrofit kit and securing the retrofit electronics. After the retrofit kit has been installed, it is necessary to attach eyelets to the terminal side of the transmitter. The eyelets enable hook-up with a HART-based communicator (see Figure 6-2).

⚠ CAUTION

Use proper earth grounding techniques when handling the smart electronics assembly. The smart electronics assembly is potentially sensitive to electric static discharge.

Figure 6-2. Spacer Assembly.

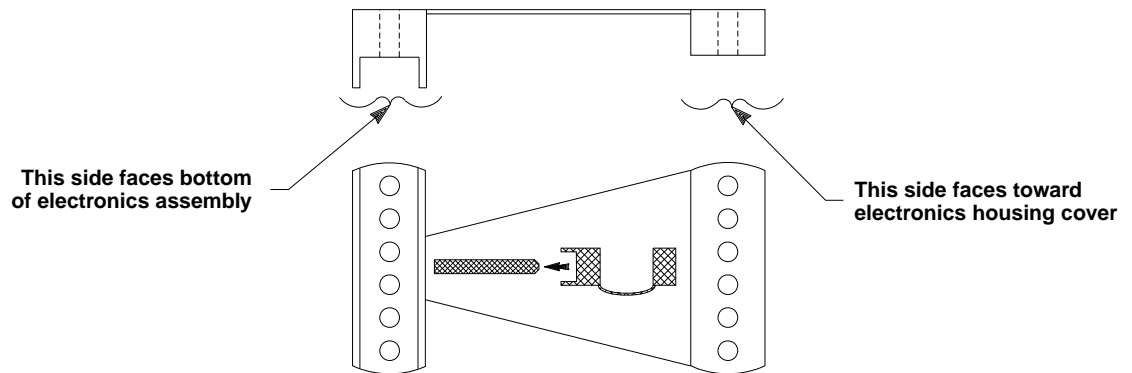

1. Slide the bottom half of one spacer over one of the rows of bayonet connectors. Then repeat the procedure for the other row.

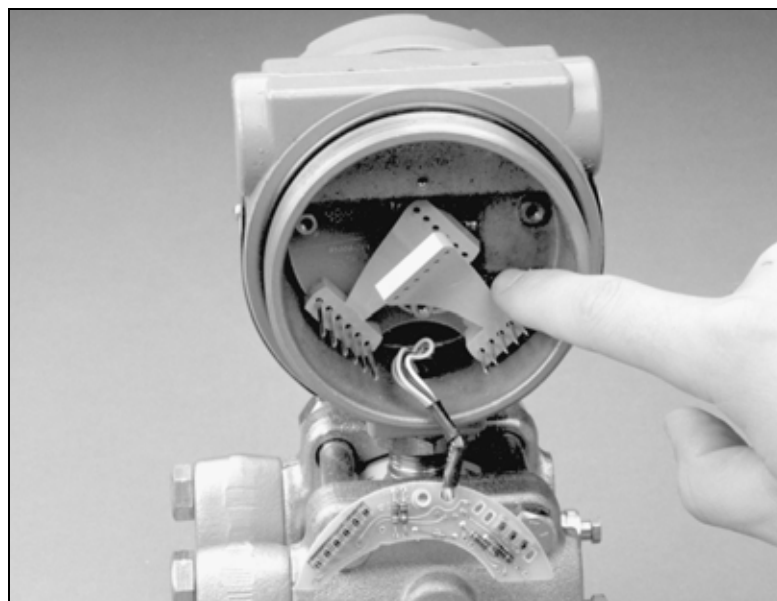

2. Align the header board with the bayonet connector pins, and slide the header board halfway down the pins.

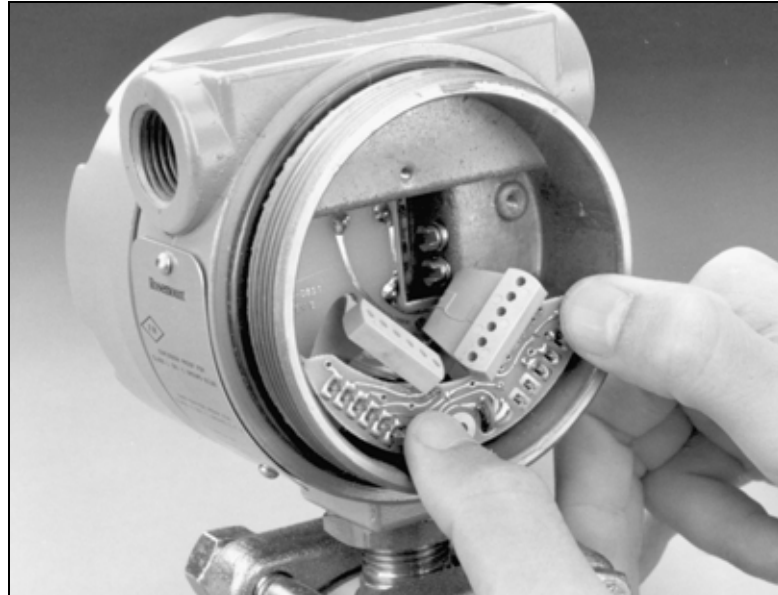

3. Align the tops of both spacers with the bayonet connector pins, and slide them down the pins, pushing firmly on both the spacers and the header board to seat the board.



4. Align the smart electronics assembly with the bayonet connector pins, making sure all pins line up with the proper receptacles. Next, push the assembly slowly inward until it is fully seated.

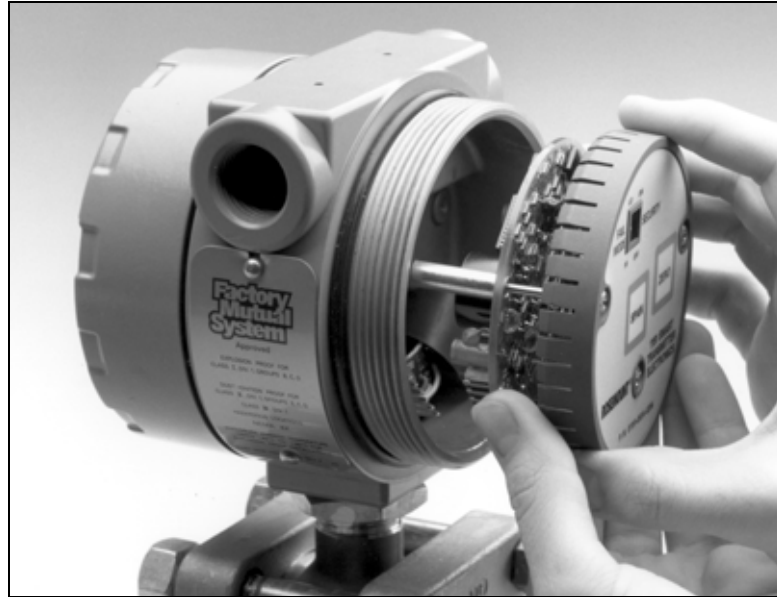

5. Tighten the three captive screws on the smart electronics assembly to secure it in place.
- ⚠ 6. Attach the electronics cover provided in the smart retrofit kit, and tighten securely.
7. Remove the cover from the terminal side of the transmitter.

Two eyelets that fit under the + and – signal terminal screws are provided to facilitate connections to HART-based communicator. The signal terminal is the upper block as indicated on the transmitter housing.

- ⚠ 8. Remove the signal terminal + and – screws. Attach an eyelet to each screw, and reinsert the screws.
9. Reattach the cover on the terminal side, and tighten securely.

CHARACTERIZATION

The transmitter is now ready to be characterized. Characterization is a one-time calibration of the sensor in the Rosemount 1151 Transmitter. During characterization, known pressures are applied to the sensor, and corresponding digital values are stored in the EEPROM located in the smart transmitter electronics. The microprocessor uses these values to make linearization corrections. The digital-to-analog converter then converts the corrected digital signal into a 4–20 mA dc output. The Rosemount 1151 Transmitter will stay in high alarm (approximately 22 mA output) until the characterization sequence is completed.

NOTE

The transmitter must be re-characterized if either the sensor module or the smart transmitter electronics are repaired or replaced.

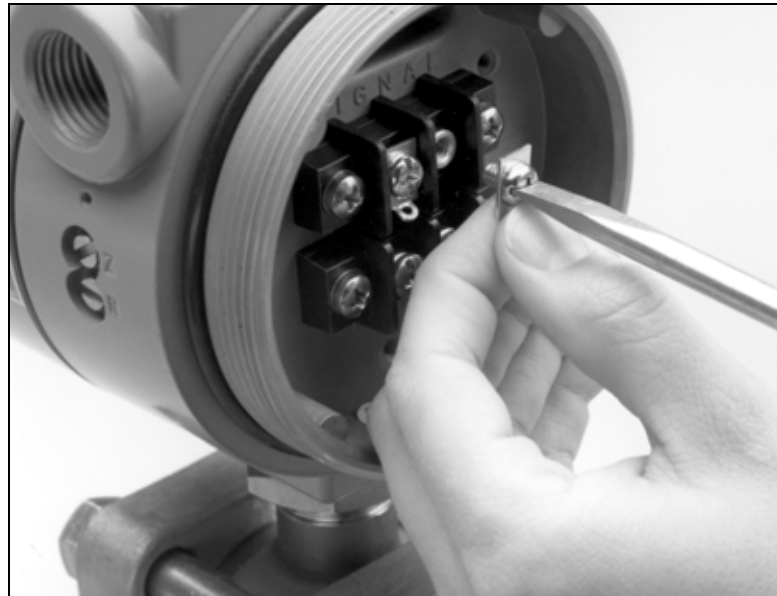

Before Characterizing the Transmitter

1. Be prepared to answer the following questions:
 - Module type (AP, DP, HP, LT) on the transmitter S/N tag?
 - Module range on the transmitter module tag?
 - Pressure units on your pressure source?
 - Serial number on the transmitter S/N tag?
- ⚠ 2. Connect the pressure source.
- ⚠ 3. Remove the terminal side cover of the Rosemount 1151 Pressure Transmitter.
- ⚠ 4. Connect power supply leads to the terminal block. Apply power to the transmitter.

NOTE

Failure to use accurate equipment may result in a transmitter that cannot meet its accuracy specification.

Rosemount 1151

Characterizing with a HART Communicator



1. Connect the HART communicator electrical connections to the SIGNAL terminal block. The HART Communicator connections are not polarity sensitive.
2. Turn the HART Communicator on by pushing the I/O button.
3. Follow the HART Communicator menus to characterize:
 - Device setup
 - Detailed setup
 - Sensor
 - Pressure sensor
 - Sensor service
 - Characterize
4. Follow the instructions on the screen.
5. Verify the new transmitter configuration:
 - Tag
 - Range points
 - Linear/square root
 - Damping
6. Verify that the Fail Safe Mode Switch and the Transmitter Security Switch on the smart electronics circuit board are correct.
7. Attach the electronics cover and tighten.
8. Put the transmitter back in service.

Appendix A Reference Information

Performance Specifications	page A-1
Functional Specifications	page A-4
Physical Specifications	page A-9
Dimensional Drawings	page A-12
Ordering Information	page A-17
1151 Parts List	page A-23
1151LT Parts List	page A-29
Display Specifications	page A-35

PERFORMANCE SPECIFICATIONS

(Zero-based calibrated ranges, reference conditions, silicone oil fill, 316 SST isolating diaphragms.)

Accuracy

Output	Model	Accuracy Specification and Span
Output Code S	Ranges 3 through 8 for DP and GP; Ranges 4 through 7 for HP	±0.075% of calibrated span between 1:1 to 10:1 of URL Accuracy = $\pm \left[0.02 \left(\frac{URL}{span} \right) - 0.1 \right]$ % of calibrated span between 10:1 and 50:1 of URL
	Square Root Mode	Accuracy = $\pm \left[0.2 + 0.05 \times \frac{URL}{span} \right]$ % of calibrated flow span for all spans
	All other ranges and transmitters	±0.25% of calibrated span for all spans
Output Codes E, G, L, and M	Ranges 3 through 5 for DP and GP	±0.2% of calibrated span for all spans
	P8 Option: Ranges 3 through 8 for DP and GP, all HP and all LT	±0.1% of calibrated span for > 10 inH ₂ O
	All other ranges and transmitters	±0.25% of calibrated span for all spans

Output Code S

Ranges 3 through 8, DP and GP transmitters;

Ranges 4 through 7, HP transmitters

±0.075% of calibrated span for spans from 1:1 to 10:1 of URL. Between 10:1 and 50:1 of URL.

$$\text{Accuracy} = \pm \left[0.02 \left(\frac{\text{URL}}{\text{span}} \right) - 0.1 \right] \% \text{ of calibrated span}$$

All other ranges and transmitters:

±0.25% of calibrated span

Square root mode:

$$\text{Accuracy} = \pm \left[0.2 + 0.05 \times \frac{\text{URL}}{\text{span}} \right] \% \text{ of calibrated flow span}$$

Output Codes E, G, L, and M

±0.2% of calibrated span for 1151DP and GP Ranges 3 through 5. All other ranges and transmitters, ±0.25% of calibrated span.

P8 Improved Performance Option:

±0.1% of calibrated span for ranges DP/GP ranges 3-8, all HP and all LT transmitters (only available with SST isolators and it must have a span great than 10 inH₂O).

All other ranges and transmitters:

±0.25% of calibrated span

Stability

Output Code S

±0.1% of URL for two years for DP and GP Ranges 3 through 8. (±0.25% for all other ranges and transmitters.)

Output Codes E and G

±0.2% of URL for six months for Ranges 3 through 5. (±0.25 for all other ranges.)

Output Codes L and M

±0.25% of URL for six months.

Temperature Effect

Output Code S [–20 to 185 °F (–29 to 85 °C)]

For DP and GP transmitter Range 4 through 8:

Zero Error = ±0.2% URL per 100 °F (56 °C)

Total Error = ±(0.2% URL + 0.18% of calibrated span) per 100 °F; double the effect for other ranges and transmitters.

Output Code E, G, L, and M [–20 to 200 °F (–29 to 93 °C)]

For Ranges 4 through 0:

Zero Error = ±0.5% URL per 100 °F.

Total Error = ±(0.5% URL + 0.5% of calibrated span) per 100 °F (56 °C); double the effect for Range 3.

Static Pressure Effect

DP Transmitters

Zero Error: ±0.25% of URL for 2,000 psi (13790 kPa) for Range 4 and 5 or ±0.5% for other ranges, correctable through rezeroing at line pressure.

Span Error: Correctable to ±0.25% of input reading per 1,000 psi (6895 kPa), or to ±0.5% for Range 3.

HP Transmitters

Zero Error: ±2.0% of URL for 4,500 psi (31027 kPa), correctable through rezeroing at line pressure.

Span Error: Correctable to ±0.25% of input reading per 1,000 psi (6895 kPa).

Vibration Effect

0.05% of URL per g to 200 Hz in any axis.

Power Supply Effect

Output Code S, E, G

Less than 0.005% of output span per volt.

Output Codes L, M

Output shift of less than 0.05% of URL for a 1 V dc power supply shift.

Load Effect

Output Code S, E, G

No load effect other than the change in power supplied to the transmitter.

Output Codes L, M

Less than 0.05% of URL effect for a change in load from 100 kV to infinite ohms.

Short Circuit Condition (Output Codes L and M only)

No damage to the transmitter will result when the output is shorted to common or to power supply positive (limit 12 V).

EMI/RFI Effect

Output shift of less than 0.1% of span when tested to SAMA PMC 33.1 from 20 to 1000 MHz and for field strengths up to 30 V/m (covers on).

Mounting Position Effect

Zero shift of up to 1 inH₂O (0.25 kPa).

With liquid level diaphragm in vertical plane, zero shift of up to 1 inH₂O (0.25 kPa). With liquid level diaphragm in horizontal plane, zero shift of up to 5 inH₂O (1.25 kPa) plus extension length on extended units. All zero shifts can be calibrated out. No effect on span.

FUNCTIONAL SPECIFICATIONS

Service

Liquid, gas, and vapor applications.

Ranges

See Table A-1 for complete list of ranges for all Rosemount 1151 transmitters.

Table A-1. Rosemount 1151 Transmitter Range Availability by Model (URL = Upper Range Limit).

Range Code	Rosemount 1151 Ranges (URL)	DP	HP	GP	DP/GP/Seals	AP	LT
3	30 inH ₂ O (7.46 kPa)	•	NA	•	NA	NA	NA
4	150 inH ₂ O (31.08 kPa)	•	•	•	•	•	•
5	750 inH ₂ O (186.4 kPa)	•	•	•	•	•	•
6	100 psi (689.5 kPa)	•	•	•	•	•	•
7	300 psi (2068 kPa)	•	•	•	•	•	NA
8	1,000 psi (6895 kPa)	•	NA	•	NA	•	NA
9	3,000 psi (20684 kPa)	NA	NA	•	NA	NA	NA
0	6,000 psi (41369 kPa)	NA	NA	•	NA	NA	NA

Minimum span equals the upper range limit (URL) divided by rangedown. Rangedown varies with the output code (see Table A-2).

Table A-2. Rangeability.

Output Code	Minimum Span	Maximum Span
E, G	URL/6	URL
L	URL/1.1	URL
M	URL/2	URL
S (DP and GP, SST, Range 3–9, HP SST, Range 4-7)	URL/50	2 × URL ⁽¹⁾
S (All others)	URL/15	2 × URL ⁽¹⁾

⁽¹⁾ Transmitter is capable of measuring from -URL to URL.

Outputs

Code S, Smart

4–20 mA dc, user selectable for linear or square root output. Digital process variable superimposed on 4–20 mA signal, available to any host that conforms to the HART protocol.

Code E, Analog

4–20 mA dc, linear with process pressure.

Code G, Analog

10–50 mA dc, linear with process pressure. Not available with the CE mark.

Code L, Low Power

0.8 to 3.2 V dc, linear with process pressure.

Code M, Low Power

1 to 5 V dc, linear with process pressure.

Table A-3. Output Code Availability

Code	1151 Output Options/Damping	DP	HP	GP	DP/GP/Seals	AP	LT
S	4–20 mA, Digital, Smart/Variable	•	•	•	•	•	•
E	4–20 mA, Linear, Analog/Variable	•	•	•	•	•	•
G ⁽¹⁾	10–50 mA, Linear, Analog/Variable	•	•	•	•	•	•
L	0.8 to 3.2 V, Linear, Low Power/Fixed	•	•	•	•	•	NA
M	1 to 5 V, Linear, Low Power/Fixed	•	•	•	•	•	NA

(1) Not available with CE mark.

Power Supply

External power supply required. Transmitter operates on:

- 12 to 45 V dc with no load for Output Codes S and E.
- 30 to 85 V dc with no load for Output Code G.
- 5 to 12 V dc for Output Code L.
- 8 to 14 V dc for Output Code M.

Where:

Figure A-1. Power Supply Load Limitations

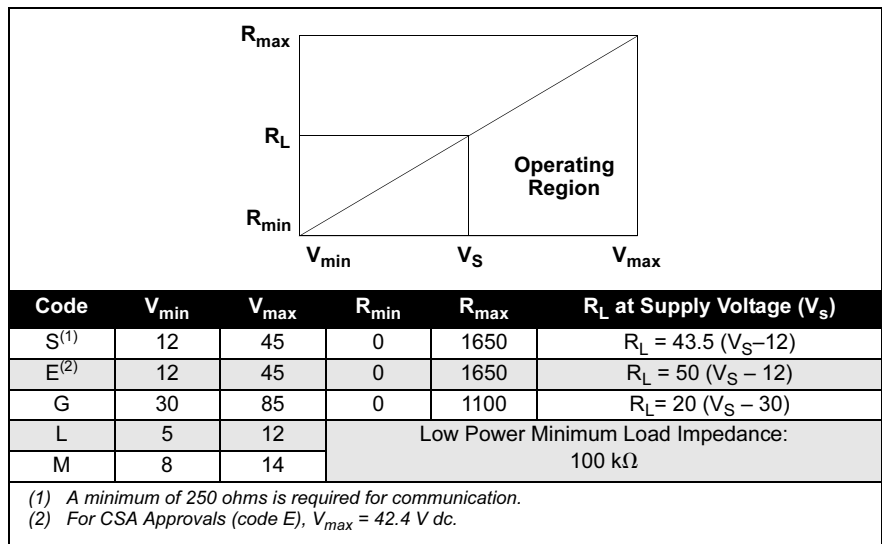

**Current Consumption (Low Power Only)
 Under Normal Operating Conditions**

Output Code L

1.5 mA dc.

Output Code M

2.0 mA dc.

Span and Zero

Output Code S

Span and zero may be accessed with local adjustments or remotely via a HART-based communicator.

Output Codes E, G, L, and M

Span and zero are continuously adjustable.

Zero Elevation and Suppression

Output Code S, E, and G.

Zero elevation and suppression must be such that the lower range value is greater than or equal to the (-URL) and the upper range value is less than or equal to the (+URL). The calibrated span must be greater than or equal to the minimum span.

Output Code L

Zero is adjustable $\pm 10\%$ of URL and span is adjustable from 90 to 100% of URL.

Output Code M

Zero is adjustable $\pm 50\%$ of URL and span is adjustable from 50 to 100% of URL.

Temperature Limits

Ambient

Code S: -40 to 185 °F (-40 to 85 °C).

Code E: -40 to 200 °F (-40 to 93 °C).

Code G, L, M: -20 to 200 °F (-29 to 93 °C).

Storage

Code S: -60 to 185 °F (-51 to 85 °C).

Codes E, G, L, M: -60 to 250 °F (-51 to 121 °C).

Process *At atmospheric pressures and above.*

Table A-4. Rosemount 1151 Temperature Limits.

Rosemount 1151DP, HP, AP, GP, LT	
Silicone Fill Sensor	-40 to 220 °F (-40 to 104 °C)
Inert Fill Sensor	0 to 160 °F (-18 to 71 °C)
Rosemount 1151LT High-Side Temperature Limits (Process Fill Fluid)	
Syltherm® XLT	-100 to 300 °F (-73 to 149 °C)
D.C.® Silicone 704	60 to 400 °F (15 to 205 °C)
D.C. Silicone 200	-40 to 400 °F (-40 to 205 °C)
Inert	-50 to 350 °F (-45 to 177 °C)
Glycerin and Water ⁽¹⁾	0 to 200 °F (-18 to 93 °C)
Neobee M-20 ⁽²⁾	0 to 400 °F (-18 to 205 °C)
Propylene Glycol and Water ⁽²⁾	0 to 200 °F (-18 to 93 °C)
Syltherm 800	-50 to 400 °F (-45 to 205 °C)

⁽¹⁾ Not suitable for vacuum service.

⁽²⁾ Not compatible with Buna-N or Ethylene-Propylene O-ring material.

NOTE

When specifying Option Codes W4 and W6, sensing element operating temperatures are 32 to 200 °F (0 to 93 °C) for silicone fill and 32 to 160 °F (0 to 71 °C) for inert fill.

Static Pressure Limits

Transmitters operate within specifications between the following limits:

Rosemount 1151DP

0.5 psia to 2,000 psig (3.45 kPa to 13790 kPa).

Rosemount 1151HP

0.5 psia to 4,500 psig (3.45 kPa to 31027 kPa).

Rosemount 1151AP

0 psia to the URL.

Rosemount 1151GP

0.5 psia (3.45 kPa) to the URL.

Rosemount 1151LT

Limit is 0.5 psia (3.45 kPa) to the flange rating or sensor rating, whichever is lower.

Overpressure Limits

Transmitters withstand the following limits without damage:

Rosemount 1151DP

0 psia to 2,000 psig (0 to 13790 kPa).

Rosemount 1151HP

0 psia to 4,500 psig (0 to 31027 kPa).

Rosemount 1151AP

0 psia to 2,000 psia (0 to 13790 kPa).

Rosemount 1151GP

Ranges 3–8: 0 psia to 2,000 psig (0 to 13790 kPa).
 Range 9: 0 psia to 4,500 psig (31027 kPa).
 Range 0: 0 psia to 7,500 psig (51710 kPa).

Rosemount 1151LT

Limit is 0 psia to the flange rating or sensor rating, whichever is lower. See Table A-5.

Table A-5. Rosemount 1151LT and Level Flange Rating Limits.

Standard	Class	Carbon Steel Rating	Stainless Steel Rating
ANSI	150	285 psig ⁽¹⁾	275 psig ⁽¹⁾
ANSI	300	740 psig ⁽¹⁾	720 psig ⁽¹⁾
ANSI	600	1,480 psig ⁽¹⁾	1,440 psig ⁽¹⁾
DIN	PN 10–40	40 bar ⁽²⁾	40 bar ⁽²⁾
DIN	PN 10/16	16 bar ⁽²⁾	16 bar ⁽²⁾
DIN	PN 25/40	40 bar ⁽²⁾	40 bar ⁽²⁾

(1) At 100 °F (38 °C), the rating decreases with increasing temperature.

(2) At 248 °F (120 °C), the rating decreases with increasing temperature.

Burst Pressure Limit

All models: 10,000 psig (68.95 MPa) burst pressure on the flanges.

Humidity Limits

0 to 100% relative humidity.

Volumetric Displacement

Less than 0.01 in³ (0.16 cm³).

Failure Mode Alarm (Smart only)

When not in multidrop mode, self-diagnosis detects a gross transmitter failure, the analog signal will be driven below 3.9 mA or above 21 mA to alert the user. High or low alarm signal is user selectable.

Level	4–20 mA Saturation Value	4–20 mA Alarm Value
Low	3.9 mA	3.8 mA
High	20.8 mA	21.75 mA

Transmitter Security (Smart only)

Activating the transmitter security function prevents changes to the transmitter configuration, including local zero and span adjustments. Security is activated by an internal switch.

Overpressure Alarm (Smart only)

If the sensor detects a negative overpressure value, the analog signal will be driven to 3.9 mA. If the sensor detects a positive overpressure value, the analog signal is driven to 20.8 mA.

Damping

Numbers given are for silicone fill fluid at room temperature. The minimum time constant is 0.2 seconds (0.4 seconds for Range 3). Inert-filled sensor values would be slightly higher.

Output Code S

Time constant is adjustable in 0.1 second increments from minimum to 16.0 seconds.

Output Codes E and G

Time constant continuously adjustable between minimum and 1.67 seconds.

Output Codes L, M

Damping is fixed at minimum time constant.

Turn-on Time

Maximum of 2.0 seconds with minimum damping. Low power output is within 0.2% of steady state value within 200 ms after application of power.

**PHYSICAL
SPECIFICATIONS**

Electrical Connections

1/2-14 NPT conduit with screw terminals and integral test jacks compatible with miniature banana plugs (Pomona 2944, 3690, or equivalent). The communicator connections are fixed to the terminal block on smart transmitters.

Process Connections

Rosemount 1151DP, HP, GP, AP

1/4-18 NPT on 2.125-in. (54-mm) centers on flanges for Ranges 3, 4, and 5.
1/4-18 NPT on 2.188-in. (56-mm) centers on flanges for Ranges 6 and 7.
1/4-18 NPT on 2.250-in. (57-mm) centers on flanges for Range 8.
1/2-14 NPT on adaptors.

For Ranges 3, 4, and 5, flange adaptors can be rotated to give centers of 2.0 in. (51 mm), 2.125 in. (54 mm), or 2.250 in. (57 mm).

Rosemount 1151LT

High pressure side: 2-, 3-, or 4-in., Class 150, 300 or 600 flange; 50, 80, or 100 mm, PN 40 or 10/16 flange.

Low pressure side: 1/4-18 NPT on flange. 1/2-14 NPT on adapter.

**1151 Process Wetted
Parts**

Isolating Diaphragms

316L SST, Alloy C-276, or Tantalum. See ordering table for availability per model type.

Drain/Vent Valves

316 SST or Alloy C-276. See ordering table for availability per model type.

Process Flanges and Adaptors

Plated carbon steel, 316 SST or CW-12MW (Cast version Alloy C-276, material per ASTM-A494). See ordering table for availability per model type.

Wetted O-rings

Viton® (other materials also available). See ordering table for availability per model type.

1151LT Process Wetted Parts

Flanged Process Connection (Transmitter High Side)

Process diaphragms, including process gasket surface
316L SST, Alloy C-276, or Tantalum.

Extension

CF-3M (cast version to 316L SST, material per ASTM-A743) or CW-12MW (Cast version of Alloy C-276, material per ASTM-A494); fits schedule 40 and 80 pipe.

Mounting Flange

Carbon steel or SST.

Reference Process Connection (Transmitter Low Side)

Isolating Diaphragms

316L SST, Alloy C-276, or tantalum.

Reference Flange and Adapter

CF-8M (Cast version of 316 SST, material per ASTM-A743).

Non-wetted Materials

Fill Fluid

Silicone oil or inert fill.

Nuts and Bolts

Plated carbon steel

Blank flange (GP and AP only)

Plated carbon steel

Electronics Housing

Low-copper aluminium. NEMA 4X.

Cover O-rings

Buna-N.

Paint

Polyurethane.

Weight

12 lb (5.4 kg) for AP, DP, GP, and HP transmitters, excluding options. See Table A-6.

Table A-6. Flange Weights with Rosemount 1151LT Transmitter.

Flange ⁽¹⁾	Flush Mount	2-inch (50mm) Extension	4-inch (100mm) Extension	6-inch (150mm) Extension
2-in., Class 150	18 (8.2)	N/A	N/A	N/A
3-in., Class 150	23 (10.4)	25 (11.3)	26 (11.8)	27 (12.3)
4-in., Class 150	29 (13.2)	32 (14.5)	34 (15.4)	36 (16.3)
2-in., Class 300	20 (9.1)	N/A	N/A	N/A
3-in., Class 300	28 (12.7)	30 (13.6)	31 (14.1)	32 (14.5)
4-in., Class 300	38 (17.2)	41 (18.6)	43 (19.5)	45 (20.4)
2-in., Class 600	22 (10.0)	N/A	N/A	N/A
3-in., Class 600	31 (14.1)	33 (15.0)	34 (15.4)	35 (15.9)
DN 50, PN10-40	20 (9.1)	N/A	N/A	N/A
DN 80, PN 25/40	25 (11.3)	27 (12.3)	28 (12.7)	29 (13.2)
DN 100, PN 10/16 DN	25 (11.3)	28 (12.7)	30 (13.6)	32 (14.5)
100, PN 25/40	29 (13.2)	32 (14.5)	34 (15.4)	36 (16.3)

(1) Stainless steel flange weights are listed.

DIMENSIONAL DRAWINGS

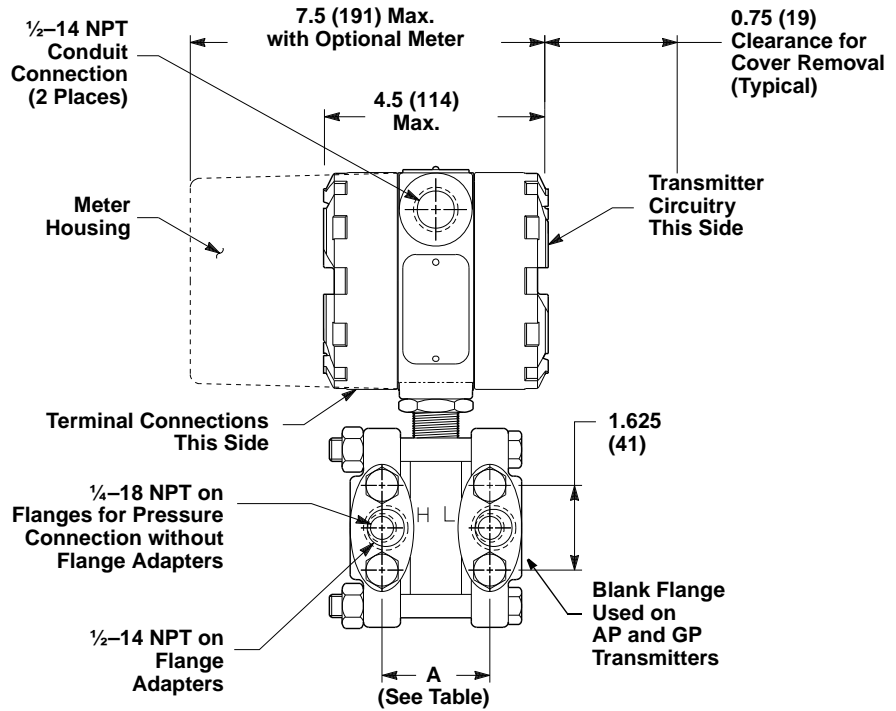

Range	Flange Distance "A" Center to Center	
	inches	mm
3, 4, 5	2.125	54
6, 7	2.188	56
8	2.250	57
9	2.281	58
0	2.328	59

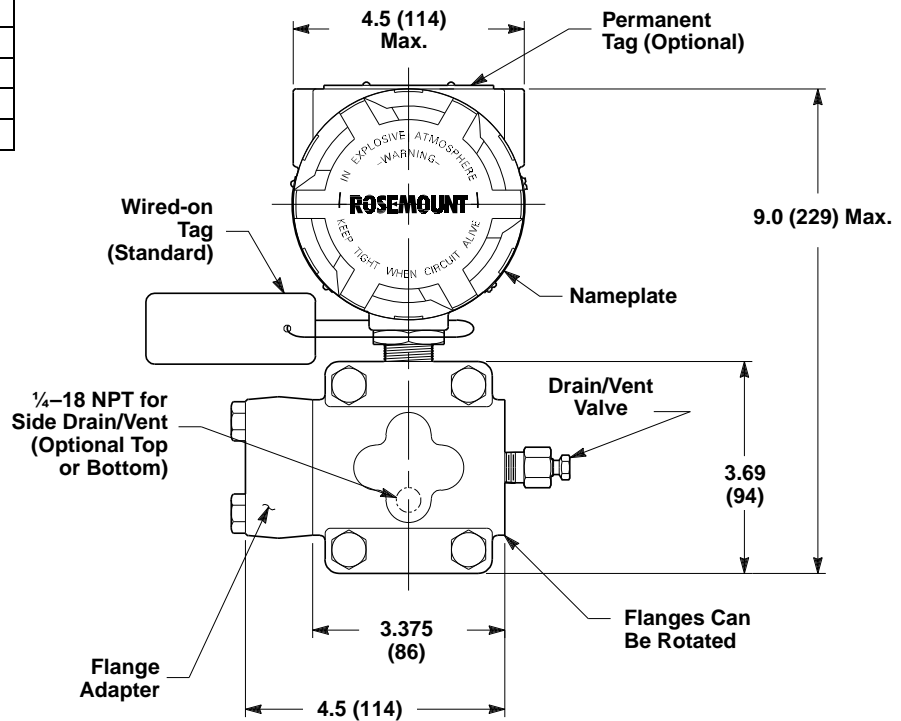

NOTE
Dimensions are in inches (millimeters).

1151LT

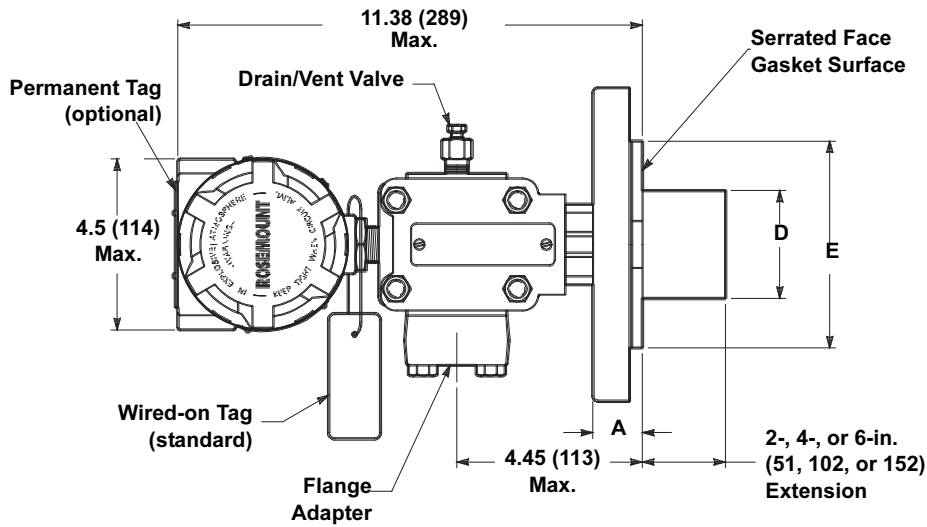

OPTIONAL FLUSHING CONNECTION RING (LOWER HOUSING)

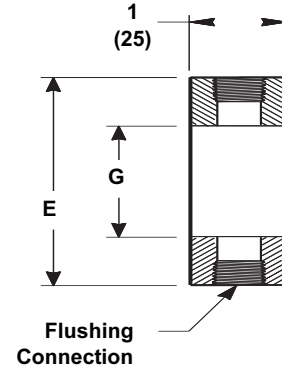

DIAPHRAGM ASSEMBLY AND MOUNTING FLANGE

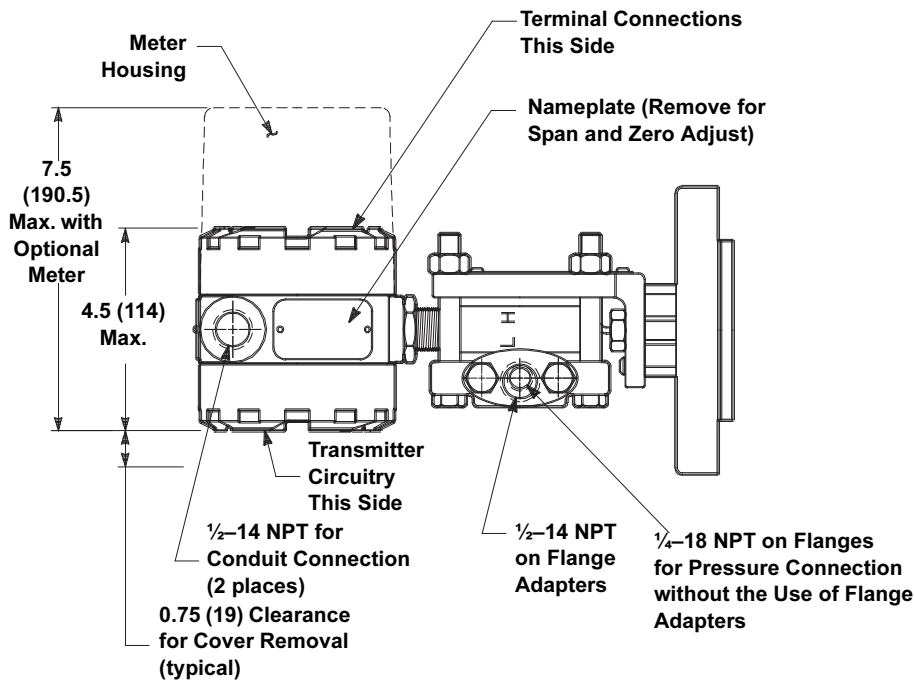
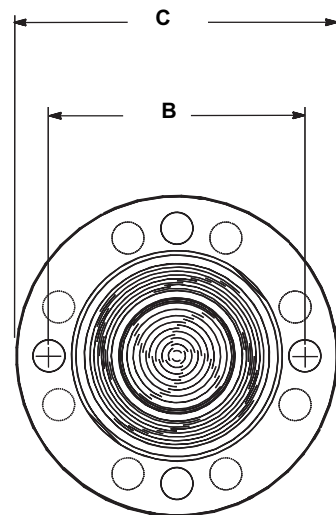

NOTE
 Dimensions are in inches (millimeters).

Table A-7. 1151LT Dimensional Specifications

Class	Pipe Size	Flange Thickness A	Bolt Circle Diameter B	Outside Diameter C	No. of Bolts	Bolt Hole Diameter	Exten. Diam. D ⁽¹⁾	O.D. Gask. Surf. E	Proc. Side G
ANSI 150	2 (51)	1.12 (28)	4.75 (121)	6.0 (152)	4	0.75 (19)	NA	3.6(92)	2.12 (54)
	3 (76)	1.31 (33)	6.0 (152)	7.5 (191)	4	0.75 (19)	2.58 (66)	5.0 (127)	3.5 (89)
	4 (102)	1.31 (33)	7.5 (191)	9.0 (229)	8	0.75 (19)	3.5 (89)	6.2 (158)	4.5 (114)
ANSI 300	2 (51)	1.25 (32)	5.0 (127)	6.5 (165)	8	0.75 (19)	NA	3.6(92)	2.12 (54)
	3 (76)	1.50 (38)	6.62 (168)	8.25 (210)	8	0.88 (22)	2.58 (66)	5.0 (127)	3.5 (89)
	4 (102)	1.62 (41)	7.88 (200)	10.0 (254)	8	0.88 (22)	3.5 (89)	6.2 (158)	4.5 (114)
ANSI 600	2 (51)	1.12 (28)	5.0 (127)	6.5 (165)	8	0.75 (19)	NA	3.6(92)	2.12 (54)
	3 (76)	1.37 (35)	6.62 (168)	6.62 (168)	8	0.88 (22)	2.58 (66)	5.0 (127)	3.5 (89)
DIN PN10-40	DN 50	26 mm	125 mm	165 mm	4	18 mm	NA	4.0 (102)	2.5 (63)
DIN	DN 80	30 mm	160 mm	200 mm	8	18 mm	65 mm	5.4 (138)	3.7 (94)
PN 25/40	DN 100	30 mm	190 mm	235 mm	8	22 mm	89 mm	6.2 (158)	4.5 (114)
DIN PN 10/16	DN 100	26 mm	180 mm	220 mm	8	18 mm	89 mm	6.2 (158)	4.5 (114)

(1) Tolerances are 0.040 (1.02), -0.020 (0.51).

Mounting Bracket Option Codes B1, B4, and B7

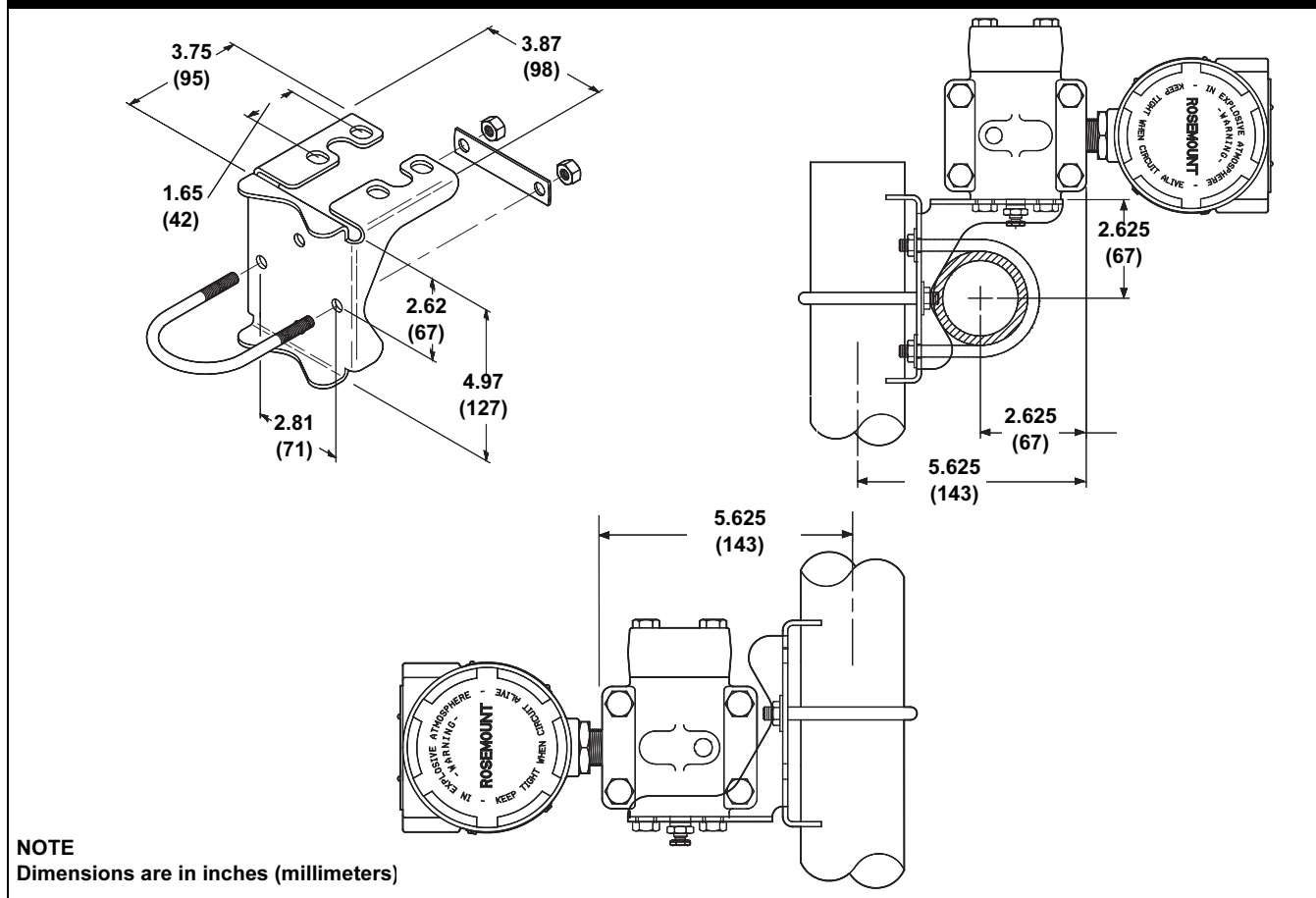

Panel Mounting Bracket Option Codes B2 and B5

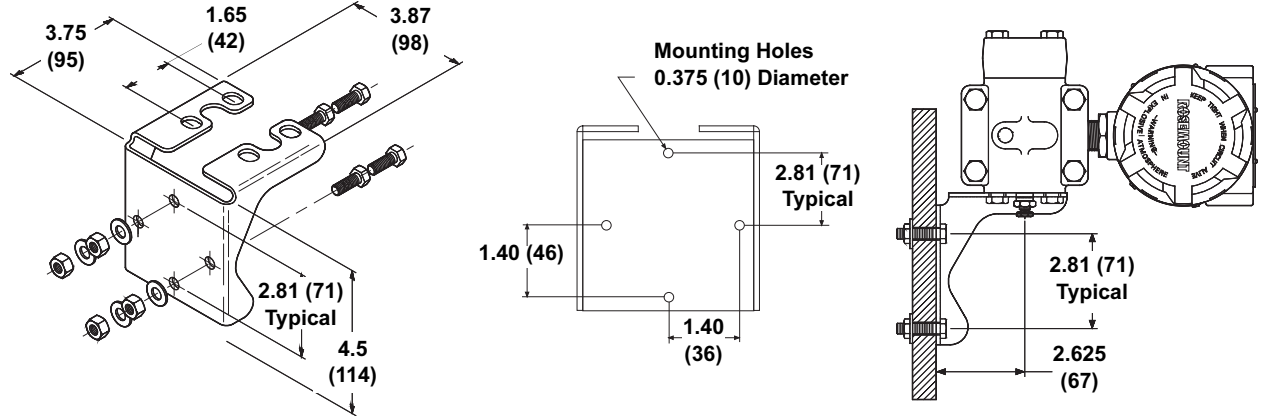

NOTE
 Dimensions are in inches (millimeters).

Flat Mounting Bracket Option Codes B3, B6, and B9

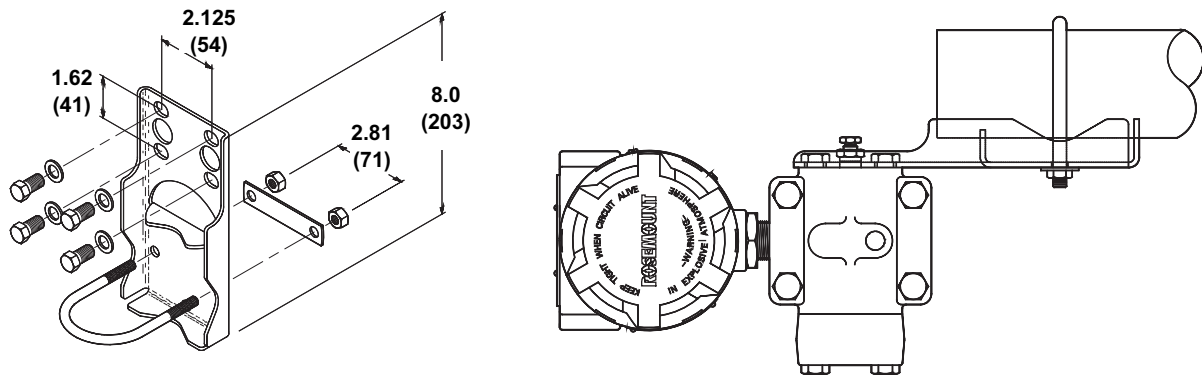

NOTE
 Dimensions are in inches (millimeters).

Meter Options

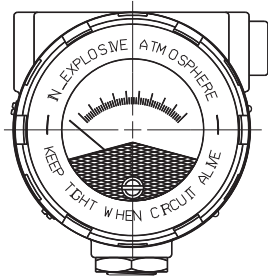

**OPTION CODE M1
LINEAR SCALE**

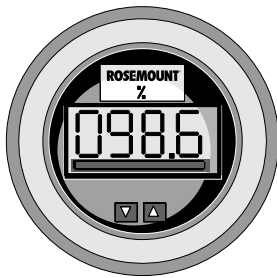

**OPTION CODE M4
LINEAR SCALE**

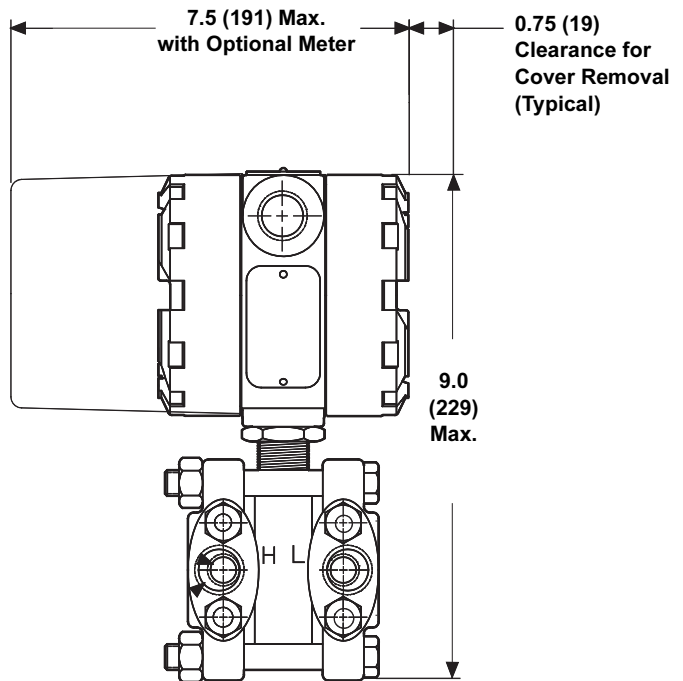

NOTE
Dimensions are in inches (millimeters).

Flange Insert

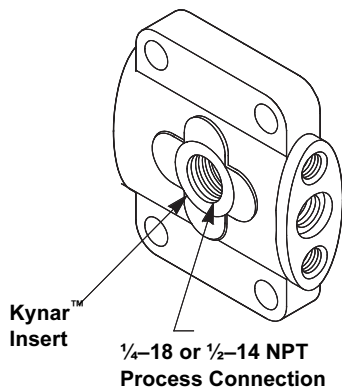

1151 Process Connections

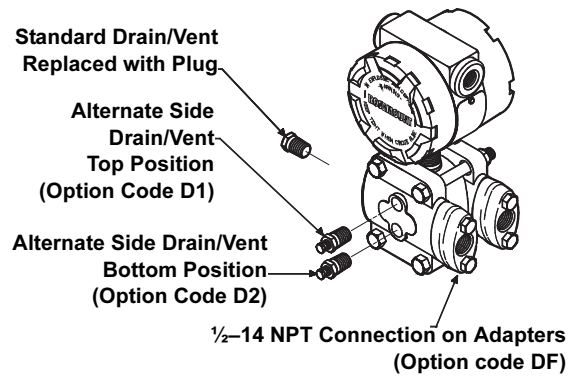

ORDERING INFORMATION

Table A-8. Rosemount 1151 Ordering Information

• = Applicable — = Not Applicable

Model	Transmitter Type	DP	HP	GP	AP			
1151DP	Differential Pressure Transmitter	•	—	—	—			
1151HP	Differential Pressure Transmitter for High Line Pressures	—	•	—	—			
1151GP	Gage Pressure Transmitter	—	—	•	—			
1151AP	Absolute Pressure Transmitter	—	—	—	•			
Code	Pressure Ranges (URL) (select one)	DP	HP	GP	AP			
3	30 inH ₂ O (7.46 kPa)	•	—	•	—			
4	150 inH ₂ O (37.3 kPa)	•	•	•	•			
5	750 inH ₂ O (186.4 kPa)	•	•	•	•			
6	100 psi (689.5 kPa)	•	•	•	•			
7	300 psi (2068 kPa)	•	•	•	•			
8	1,000 psi (6895 kPa)	•	—	•	•			
9	3,000 psi (20684 kPa)	—	—	•	—			
0	6,000 psi (41369 kPa)	—	—	•	—			
Code	Transmitter Output (select one)	DP	HP	GP	AP			
S	4–20 mA with Digital Signal based on HART Protocol (Smart)	•	•	•	•			
E	4–20 mA, Linear with Input	•	•	•	•			
G ⁽¹⁾	10–50 mA, Linear with Input	•	•	•	•			
L ⁽²⁾	Low Power 0.8 to 3.2 Vdc	•	•	•	•			
M ⁽²⁾	Low Power 1 to 5 Vdc	•	•	•	•			
MATERIALS OF CONSTRUCTION ⁽³⁾								
Code	Flanges/Adapters	Drains/Vents	Diaphragms	Fill Fluid	DP	HP	GP ⁽⁴⁾	AP ⁽⁴⁾
52	Nickel-plated Carbon Steel	316 SST	316L SST	Silicone	•	•	•	•
53	Nickel-plated Carbon Steel	316 SST	Alloy C-276	Silicone	•	•	•	•
55	Nickel-plated Carbon Steel	316 SST	Tantalum	Silicone	•	—	•	—
22	316 SST	316 SST	316L SST	Silicone	•	•	•	•
23	316 SST	316 SST	Alloy C-276	Silicone	•	•	•	•
25	316 SST	316 SST	Tantalum	Silicone	•	—	•	—
33 ⁽⁵⁾	Cast C-276	Alloy C-276	Alloy C-276	Silicone	•	•	•	•
35	Cast C-276	Alloy C-276	Tantalum	Silicone	•	—	•	—
73 ⁽⁵⁾	316 SST	Alloy C-276	Alloy C-276	Silicone	•	•	•	•
83 ⁽⁵⁾	Nickel-plated Carbon Steel	Alloy C-276	Alloy C-276	Silicone	•	•	•	•
5A	Nickel-plated Carbon Steel	316 SST	316L SST	Inert	•	—	•	—
5B	Nickel-plated Carbon Steel	316 SST	Alloy C-276	Inert	•	—	•	—
5D	Nickel-plated Carbon Steel	316 SST	Tantalum	Inert	•	—	•	—
2A	316 SST	316 SST	316L SST	Inert	•	—	•	—
2B	316 SST	316 SST	Alloy C-276	Inert	•	—	•	—
2D	316 SST	316 SST	Tantalum	Inert	•	—	•	—
3B	Cast C-276	Alloy C-276	Alloy C-276	Inert	•	—	•	—
3D	Cast C-276	Alloy C-276	Tantalum	Inert	•	—	•	—
7B ⁽⁵⁾	316 SST	Alloy C-276	Alloy C-276	Inert	•	—	•	—
8B ⁽⁵⁾	Nickel-plated Carbon Steel	Alloy C-276	Alloy C-276	Inert	•	—	•	—
Code	Mounting Brackets (optional - select one)	DP	HP	GP	AP			
B1	Bracket, 2-in. Pipe Mount	•	•	•	•			
B2	Bracket, Panel Mount	•	•	•	•			
B3	Bracket, Flat, 2-in. Pipe Mount	•	•	•	•			
B4	B1 Bracket w/Series 316 SST Bolts	•	•	•	•			
B5	B2 Bracket w/Series 316 SST Bolts	•	•	•	•			
B6	B3 Bracket w/Series 316 SST Bolts	•	•	•	•			
B7	316 SST B1 Bracket with 316 SST Bolts	•	•	•	•			
B9	316 SST B3 Bracket with 316 SST Bolts	•	•	•	•			
Code	LCD Display ⁽⁶⁾ (optional - select one)	DP	HP	GP	AP			
M1	Analog Scale, Linear Meter, 0–100%	•	•	•	•			

Rosemount 1151

Table A-8. Rosemount 1151 Ordering Information

M2	Analog Scale, Square Root Meter, 0–100% Flow		•	•	—	—
M4 ⁽⁷⁾	LCD Display, Linear Meter, 0–100%		•	•	•	•
M6	Analog Scale, Square Root Meter, 1–10√		•	•	—	—
M7 ⁽⁷⁾⁽⁸⁾	LCD Display, Linear Meter, Special Configuration		•	•	•	•
M8 ⁽⁷⁾	LCD Display Square Root Meter, 0–100% Flow		•	•	—	—
M9 ⁽⁷⁾	LCD Display, Square Root Meter, 0–10√		•	•	—	—
Code	Product Certifications (optional - select one)		DP	HP	GP	AP
E8	ATEX Flameproof		•	•	•	•
I1 ⁽⁹⁾	ATEX Intrinsic Safety	NOTE FM explosion-proof approval is standard.	•	•	•	•
N1 ⁽⁹⁾	ATEX Type n		•	•	•	•
I5 ⁽⁹⁾	FM Intrinsically Safe, Division 2		•	•	•	•
K5 ⁽⁹⁾	FM Explosion-Proof, Dust Ignition-proof, Intrinsically Safe, Division 2		•	•	•	•
C6 ⁽⁹⁾	CSA Explosion-Proof, Intrinsically Safe		•	•	•	•
I6 ⁽⁹⁾	CSA Intrinsically Safe		•	•	•	•
K6 ⁽⁹⁾	CSA Explosion-Proof, Dust Ignition-proof, Intrinsically Safe, Division 2		•	•	•	•
E6	CSA Explosion-Proof, Dust Ignition-proof, Division 2		•	•	•	•
E7	SAA Flameproof, Dust Ignition-proof		•	•	•	•
I7 ⁽⁹⁾	SAA Intrinsic Safety		•	•	•	•
N7 ⁽⁹⁾	SAA Type n		•	•	•	•
C5 ⁽¹⁰⁾	Measurement Canada Accuracy Approval		•	•	•	•
Code	Housing (optional - select one)		DP	HP	GP	AP
H1 ⁽¹¹⁾	SST Non-wetted Parts on Transmitter without Meter		•	•	•	•
H2 ⁽¹¹⁾	SST Non-wetted Parts on Transmitter with Meter		•	•	•	•
H3	SST Housing, Covers, Conduit Plug, Lock-nut, without Meter		•	•	•	•
H4	SST Housing, Covers, Conduit Plug, Lock-nut, with Meter		•	•	•	•
C2 ⁽¹²⁾	M20 Conduit Threads		•	•	•	•
J1	G½ Conduit Threads		•	•	•	•
Code	Terminal Blocks (optional - select one)		DP	HP	GP	AP
R1	Integral Transient Protection (Only available with output options S and E)		•	•	•	•
Code	Bolts for Flanges and Adapters (optional - select one)		DP	HP	GP	AP
L3	ASTM A193-B7 Flange and Adapter Bolts		•	•	•	•
L4	316 SST Flange and Adapter Bolts		•	•	•	•
L5	ASTM A193-B7M Flange and Adapter Bolts		•	•	•	•
Code	Process Connections (optional⁽¹³⁾)	Materials	DP	HP	GP	AP
D1	Side Drain/ Vent, Top	316 SST	•	•	•	•
		Cast C-276	•	•	•	•
D2	Side Drain/ Vent, Bottom	316 SST	•	•	•	•
		Cast C-276	•	•	•	•
DF	½–14 NPT Flange adapter(s)- Material determined by flange material	Carbon Steel	•	•	•	•
		316 SST	•	•	•	•
		Cast C-276	•	•	•	•
D4 ⁽¹⁴⁾	Conformance to DIN EN61518 Ranges 3, 4, 5 with ¼ NPT Process Connections Thread (Available in Germany Only)		•	•	—	—
D5 ⁽¹⁴⁾	Conformance to DIN EN61518 Ranges 6, 7, 8, without ¼ NPT Process Connections Thread (Available in Germany Only)		•	•	—	—
D6	316 SST Low Side Blank Flange		—	—	•	•
D9	JIS Process Connection—RC ¼ Flange with RC ½ Flange Adapter	Carbon Steel	•	•	•	•
		316 SST	•	•	•	•
		Cast C-276	•	•	•	•
G1	DIN Spacing (Single Entry Port, No Side V/D Hole Flange)		•	•	•	•
G2	DIN Spacing (Single Entry Port, Two Side V/D Hole Flange)		•	•	•	•
G3	DIN Spacing (Dual Entry Port, No Side V/D Hole Flange)		•	•	•	•
G4	DIN Spacing (Dual Entry Port, One Top Side V/D Hole Flange)		•	•	•	•
G5	DIN Spacing (Dual Entry Port, One Bottom Side V/D Hole Flange)		•	•	•	•
G6	DIN Spacing (Dual Entry Port, Two Side V/D Hole Flange)		•	•	•	•
K1 ⁽¹⁵⁾	Kynar insert, ¼–18 NPT		•	—	•	—
K2 ⁽¹⁵⁾	Kynar insert, ½–14 NPT		•	—	•	—
S1 ⁽¹⁶⁾⁽¹⁷⁾	Assemble to one Rosemount 1199 diaphragm seal		•	—	•	—
S2 ⁽¹⁶⁾⁽¹⁷⁾	Assemble to two Rosemount 1199 diaphragm seals		•	—	—	—

Table A-8. Rosemount 1151 Ordering Information

S4 ⁽¹⁷⁾⁽¹⁸⁾	Assemble to Rosemount 1195 Integral Orifice	•	—	—	—
S6 ⁽¹⁷⁾	Assemble to Rosemount 304 Manifold or Connection System	•	•	•	•
Code	Wetted O-ring Material (optional - select one)	DP	HP	GP	AP
W2	Buna-N	•	•	•	•
W3	Ethylene-Propylene	•	•	•	•
W4	Aflas	•	•	•	•
W6 ⁽¹⁹⁾⁽²⁰⁾	Spring-loaded PTFE	•	—	•	•
W7 ⁽²⁰⁾⁽²¹⁾	PTFE	•	—	•	•
Code	Special Configuration (Software) (optional - select one)	DP	HP	GP	AP
CN ⁽²²⁾⁽²³⁾	Analog Output Levels Compliant with NAMUR Recommendation NE43: 27-June-1996 and Low Alarm Level	•	•	•	•
C4 ⁽²²⁾⁽²³⁾	Analog Output Levels Compliant with NAMUR Recommendation NE43: 27-June-1996 and High Alarm Level	•	•	•	•
C9 ⁽²³⁾	Software Configuration (Requires completed Configuration Data Sheet)	•	•	•	•
Code	Special Certifications (optional - select one)	DP	HP	GP	AP
Q4	Calibration Certificate	•	•	•	•
Q8 ⁽²⁴⁾	Material Traceability per EN 10204 3.1.B	•	•	•	•
Q16 ⁽²⁵⁾	Surface Finish Certification for Sanitary Remote Seals	•	•	•	•
Code	Toolkit Total System Performance Reports (optional - select one)	DP	HP	GP	AP
QZ ⁽²⁵⁾	Remote Seal System Performance Calculation Report	•	—	•	—
Code	Procedures (optional - select one)	DP	HP	GP	AP
P1 ⁽²⁶⁾	Hydrostatic Testing, 150% Maximum Working Pressure	•	•	•	•
P2 ⁽²⁷⁾	Cleaning for Special Service	•	•	•	•
P3	Cleaning for <1 PPM Chlorine/Fluorine	•	•	•	•
Code	Outputs (optional - select one)	DP	HP	GP	AP
V1 ⁽²⁸⁾	Reverse Output	—	—	•	—
V2 ⁽²⁹⁾	4–20 mV Test Signal	•	•	•	•
V3 ⁽²⁹⁾	20–100 mV Test Signal	•	•	•	•
Typical Model Number: 1151DP 4 S 52 B3 M4					

- (1) Output Code G is not available with CE Mark.
- (2) Meter or SST housing not valid with this option.
- (3) Bolts and conduit plugs are plated carbon steel.
- (4) On GP and AP transmitters, the low-side flange is plated carbon steel. For a stainless-steel low-side flange, order process connection Option Code D6.
- (5) These selections meet NACE material recommendations per MR 01-75.
- (6) Not available with Output Codes L or M, or Option Codes V2 or V3.
- (7) Not available with Output Codes G, V2, or V3.
- (8) Specify the range, mode, and engineering units. The 20 mA value must be greater than the 4 mA value.
- (9) Not available with Output Codes E, G, L, or M.
- (10) Limited availability depending on transmitter type and range. Contact an Emerson Process Management representative.
- (11) Option includes SST housing, covers, conduit plug, locknut, L4 bolting, and D6 low side blank flange for GP and AP transmitters. Option Codes L4 and D6 parts are included with housing Option Codes H1 and H2.
- (12) Not available with Output Codes L or M. Available only with aluminum housing.
- (13) Allowable combinations are: D1, D2, D6 or D6, S1.
- (14) Material Traceability Certificate Option Q8 available.
- (15) The maximum working pressure on this option is 300 psig. Available only with materials of construction Option Code 2x.
- (16) This option may only be used on Ranges 4–8.
- (17) "Assemble-to" items are specified separately and require a completed model number.
- (18) This option has a maximum static pressure rating of 3,000 psi, and is available only for Ranges 3, 4, and 5.
- (19) Contains a Alloy C-276 spring that is wetted by the process.
- (20) Available for the ranges of DP (3-8), AP (4-8), and GP (3-8).
- (21) PTFE O-ring has seal property limitations; Consult an Emerson Process Management representative for more information.
- (22) NAMUR-Compliant operation is pre-set at the factory and cannot be changed to standard operation in the field.
- (23) Available with Output Code S only.
- (24) This option is available for the transmitter flange and adapters only.
- (25) Requires one of the Diaphragm Seal Assembly codes (S1 or S2).
- (26) Hydrostatic testing for Range 0, 125% maximum working pressure.
- (27) Fluorolube[®] grease on wetted O-rings.
- (28) Reverse output option is not needed with smart electronics; configured via HART-based communicator.
- (29) Not available with Output Codes L or M.

Rosemount 1151

Table A-9. Rosemount 1151LT Flange Mounted Liquid Level Transmitter.

Model	Product Description			
1151LT	Flange-Mounted Liquid Level Transmitter			
Code	Range			
4	150 inH ₂ O (0–635 to 0–3,810 mmH ₂ O)			
5	750 inH ₂ O (0–3,175 to 0–19,050 mmH ₂ O)			
6	2,770 inH ₂ O (0–11.96 to 0–70.36 mmH ₂ O)			
Code	Output			
S	4–20 mA with Digital Signal based on HART Protocol (Smart)			
E	4–20 mA, Linear with Input			
G ⁽¹⁾	10–50 mA, Linear with Input			
Code	Size	Material	Extension Length	
G0	2 in./DN 50	316L SST	Flush Mount Only	When specifying these option codes, a lower housing must be selected from the flushing connection options.
H0	2 in./DN 50	Alloy C-276	Flush Mount Only	
J0	2 in./DN 50	Tantalum	Flush Mount Only	
A0	3 in./DN 80	316L SST	Flush Mount	
A2	3 in./DN 80	316L SST	2 in./50 mm	
A4	3 in./DN 80	316L SST	4 in./100 mm	
A6	3 in./DN 80	316L SST	6 in./150 mm	
B0	4 in./DN 100	316L SST	Flush Mount	NOTE Extension diameters are sized to fit Schedule 80 pipe. Consult factory for Schedule 40 pipe.
B2	4 in./DN 100	316L SST	2 in./50 mm	
B4	4 in./DN 100	316L SST	4 in./100 mm	
B6	4 in./DN 100	316L SST	6 in./150 mm	
C0	3 in./DN 80	Alloy C-276	Flush Mount	
C2	3 in./DN 80	Alloy C-276	2 in./50 mm	
C4	3 in./DN 80	Alloy C-276	4 in./100 mm	
C6	3 in./DN 80	Alloy C-276	6 in./150 mm	
D0	4 in./DN 100	Alloy C-276	Flush Mount	
D2	4 in./DN 100	Alloy C-276	2 in./50 mm	
D4	4 in./DN 100	Alloy C-276	4 in./100 mm	
D6	4 in./DN 100	Alloy C-276	6 in./150 mm	
E0	3 in./DN 80	Tantalum	Flush Mount Only	
F0	4 in./DN 100	Tantalum	Flush Mount Only	
MOUNTING FLANGE				
Code	Size	Rating	Material	Applicable with these High Pressure Side Diaphragm Sizes
M	2-in.	Class 150	CS	2 in./DN 50
A	3-in.	Class 150	CS	3 in./DN 80
B	4-in.	Class 150	CS	4 in./DN 100
N	2-in.	Class 300	CS	2 in./DN 50
C	3-in.	Class 300	CS	3 in./DN 80
D	4-in.	Class 300	CS	4 in./DN 100
P	2-in.	Class 600	CS	2 in./DN 50
E	3-in.	Class 600	CS	3 in./DN 80
X	2-in.	Class 150	SST	2 in./DN 50
F	3-in.	Class 150	SST	3 in./DN 80
G	4-in.	Class 150	SST	4 in./DN 100
Y	2-in.	Class 300	SST	2 in./DN 50
H	3-in.	Class 300	SST	3 in./DN 80
J	4-in.	Class 300	SST	4 in./DN 100
Z	2-in.	Class 600	SST	2 in./DN 50
L	3-in.	Class 600	SST	3 in./DN 80
Q	DN 50	PN 10-40	CS	2 in./DN 50
R	DN 80	PN 40	CS	3 in./DN 80
S	DN 100	PN 40	CS	4 in./DN 100
V	DN 100	PN 10/16	CS	4 in./DN 100

Table A-9. Rosemount 1151LT Flange Mounted Liquid Level Transmitter.

K	DN 50	PN 10-40	SST	2 in./DN 50
T	DN 80	PN 40	SST	3 in./DN 80
U	DN 100	PN 40	SST	4 in./DN 100
W	DN 80	PN 10/16	SST	4 in./DN 100
SENSOR MODULE AND LOW-SIDE MATERIALS OF CONSTRUCTION				
Code	Low-Side Flange and Adapter	Drain/ Vent Valves	Low-Side Isolator Diaphragm	Low-Side Fluid Fill
52	Nickel-plated CS	316 SST	316L SST	Silicone
55	Nickel-plated CS	316 SST	Tantalum	Silicone
22	316 SST	316 SST	316L SST	Silicone
23	316 SST	316 SST	Alloy C-276	Silicone
25	316 SST	316 SST	Tantalum	Silicone
33	Cast C-276	Alloy C-276	Alloy C-276	Silicone
35	Cast C-276	Alloy C-276	Tantalum	Silicone
5D	Nickel-plated CS	316 SST	Tantalum	Inert
2A	316 SST	316 SST	316L SST	Inert
2B	316 SST	316 SST	Alloy C-276	Inert
2D	316 SST	316 SST	Tantalum	Inert
3B	Cast C-276	Alloy C-276	Alloy C-276	Inert
3D	Cast C-276	Alloy C-276	Tantalum	Inert
Code	Process Fill - High Pressure Side		Temperature Limits	
A	Syltherm XLT		-100 to 300 °F (-73 to 135 °C)	
C	D. C. Silicone 704		60 to 400 °F (15 to 205 °C)	
D	D. C. Silicone 200		-40 to 400 °F (-40 to 205 °C)	
H	Inert		-50 to 350 °F (-45 to 177 °C)	
G	Glycerin and Water		0 to 200 °F (-17 to 93 °C)	
N	Neobee M-20		0 to 400 °F (-17 to 205 °C)	
P	Propylene Glycol and Water		0 to 200 °F (-17 to 93 °C)	
Code	Options			
S1 ⁽²⁾⁽³⁾	Assemble to one Rosemount 1199 diaphragm seal			
LCD Display				
M1 ⁽⁴⁾	Analog Scale, Linear Meter 0-100%			
M4 ⁽⁴⁾	LCD Display, 0-100%			
M7 ⁽⁴⁾⁽⁵⁾	LCD Display, Linear, Special Configuration			
HARZARDOUS LOCATIONS CERTIFICATIONS				
E8	ATEX Flameproof			
I1 ⁽⁶⁾	ATEX Intrinsic Safety			
N1 ⁽⁶⁾	ATEX Type n			
I5 ⁽⁶⁾	FM Intrinsically Safe, Division 2			
K5 ⁽⁶⁾	FM Explosion-Proof, Dust Ignition-proof, Intrinsically Safe, Division 2			
C6 ⁽⁶⁾	CSA Explosion-Proof, Intrinsically Safe			
I6 ⁽⁶⁾	CSA Intrinsically Safe			
K6 ⁽⁶⁾	CSA Explosion-Proof, Dust Ignition-proof, Intrinsically Safe, Division 2			
E6	CSA Explosion-Proof, Dust Ignition-proof, Division 2			
E7	SAA Flameproof, Dust Ignition-proof			
I7 ⁽⁶⁾	SAA Intrinsic Safety			
N7 ⁽⁶⁾	SAA Type n			
C5 ⁽⁷⁾	Measurement Canada Accuracy Approval			
OTHER OPTIONS				
W5	Copper O-ring for Vacuum Service (Nonwetted)			
C2 ⁽⁸⁾	M20 Conduit Threads			
Q4	Calibration Data Sheet			
Q8 ⁽⁹⁾	Material Traceability per EN 10204 3.1B			
Q16	Surface Finish Certification for Sanitary Remote Seals (all options)			
QZ	Remote Seal System Performance Calculation Report			

NOTE
FM explosion-proof approval is standard.

Rosemount 1151

Table A-9. Rosemount 1151LT Flange Mounted Liquid Level Transmitter.

V1 ⁽¹⁰⁾	Reverse Output
V2	4–20 mV Test Signal
V3	20–100 mV Test Signal
F_	Select One Code from Flushing Connections Lower Housing Option. See Table A-10.

Typical Model Number: 1151LT 4 S A0 A 52 D F1

- (1) Not available with Output Codes E and G.
- (2) For welded capillary assemblies, order sensor module and low-side materials of construction Option Code 22 (refer to 00813-0100-4016 for more information).
- (3) "Assemble-to" items are specified separately and require a completed model number.
- (4) Not available with Option Codes V2, or V3.
- (5) Specify the Range, Mode, and Engineering Units. Also, the 20 mA value must be greater than the 4 mA value.
- (6) Not available with Output Codes E and G.
- (7) Limited availability depending on transmitter type and range. Contact an Emerson Process Management representative.
- (8) Not available with Output Codes L or M. Available only with aluminum housing.
- (9) Available for the diaphragm, upper housing, flange, adapter, extension, and lower housing.
- (10) Reverse output option is not needed with smart electronics; configured via HART-based communicator.

Table A-10. Flushing Connections Lower Housing Options

● = Applicable — = Not Applicable

Code	Flushing Connection Ring Material (Lower Housing)	Flushing Connections	Size	Diaphragm Size		
				2-in.	3-in.	4-in.
F1	SST	1	1/4 - 18 NPT	●	●	●
F2	SST	2	1/4 - 18 NPT	●	●	●
F3 ⁽¹⁾	Cast C-276	1	1/4 - 18 NPT	●	●	●
F4 ⁽¹⁾	Cast C-276	2	1/4 - 18 NPT	●	●	●
F7	SST	1	1/2 - 14 NPT	●	●	●
F8	SST	2	1/2 - 14 NPT	●	●	●
F9	Cast C-276	1	1/2 - 14 NPT	●	●	●
F0	Cast C-276	2	1/2 - 14 NPT	●	●	●

- (1) Not available with high pressure side Option Codes A0, B0, and G0.

Tagging

The transmitter will be tagged, at no charge, in accordance with customer requirements. All tags are stainless steel. The standard tag is wired to the transmitter. Tag character height is 0.125 in. (0.318 cm). A permanently attached tag is available upon request.

Calibration

Transmitters are factory calibrated to customer's specified range. If calibration is not specified, the transmitters are calibrated at maximum range. Calibration is performed at ambient temperature and pressure.

1151 PARTS LIST

Item numbers are references to figure callouts (page A-29 and page A-30).

Table A-11. Rosemount 1151 DP, HP, GP, and AP Pressure Transmitters

Electronics – One spare part recommended for every 25 transmitters.		
Part Description	Item No.	Part Number
S Smart Output Code		
Smart Retrofit Kit ⁽¹⁾		01151-0935-0001
Smart Transmitter Electronics ⁽²⁾	24	01151-0948-0203
Board Spacer Kit (pkg of 12)	25	01151-0813-0001
Terminal Eyelet Kit (pkg of 12)		01151-0814-0001
Standoff Kit (pkg of 12)		01151-0815-0001
Cover ⁽²⁾		01151-1045-0001
Cover O-ring (pkg of 12)		01151-0033-0003
E Output Code, 4–20 mA dc		
Amplifier Circuit Board	4	01151-0137-0007
Calibration Circuit Board	6	01151-0139-0001
G Output Code, 10–50 mA dc		
Amplifier Circuit Board	4	01151-0597-0001
Calibration Circuit Board	6	01151-0139-0001
L Output Code, 0.8–3.2 V, Low Power		
Amplifier Circuit Board	4	01151-0507-0001
Calibration Circuit Board	6	01151-0509-0001
M Output Code, Output Code, 1-5 V, Low Power		
Amplifier Circuit Board	4	01151-0507-0002
Calibration Circuit Board	6	01151-0509-0002
Sensor Modules (Silicone Fill)–One spare part recommended for every 50 transmitters.		
Part Description	Item No.	Part Number
Range 3 DP, GP (30 in H₂O)	19	
316L SST		01151-0011-0032
Alloy C-276		01151-0011-0033
Tantalum		01151-0011-0035
Range 4 DP, GP (150 in H₂O)	19	
316L SST		01151-0011-0042
Alloy C-276		01151-0011-0043
Tantalum		01151-0011-0045
Range 4 HP (150 in H₂O)	19	
316L SST		01151-0112-0042
Alloy C-276		01151-0112-0043
Range 4 AP (11 in H_gA)	19	
316L SST		01151-0054-0042
Alloy C-276		01151-0054-0043

(1) Kit contains enough parts for one transmitter and includes the smart transmitter electronics, board spacers, terminal eyelets, standoffs, cover, and cover O-ring.

(2) Package contains quantity required for one transmitter.

Sensor Modules (Silicone Fill)—One spare part recommended for every 50 transmitters.		
Part Description	Item No.	Part Number
Range 5 DP, GP (750 in H₂O)	19	
316L SST		01151-0011-0052
Alloy C-276		01151-0011-0053
Tantalum		01151-0011-0055
Range 5 HP (750 in H₂O)	19	
316L SST		01151-0112-0052
Alloy C-276		01151-0112-0053
Range 5 AP (55 in H_gA)	19	
316L SST		01151-0054-0052
Alloy C-276		01151-0054-0053
Range 6 DP, GP (100 psi)	19	
316L SST		01151-0041-0062
Alloy C-276		01151-0041-0063
Tantalum		01151-0041-0065
Range 6 HP (100 psid)	19	
316L SST		01151-0112-0062
Alloy C-276		01151-0112-0063
Range 6 AP (100 psia)	19	
316L SST		01151-0054-0062
Alloy C-276		01151-0054-0063
Range 7 DP, GP (300 psi)	19	
316L SST		01151-0041-0072
Alloy C-276		01151-0041-0073
Tantalum		01151-0041-0075
Range 7 HP (300 psid)	19	
316L SST		01151-0112-0072
Alloy C-276		01151-0112-0073
Range 7 AP (300 psia)	19	
316L SST		01151-0054-0072
Alloy C-276		01151-0054-0073
Range 8 DP, GP (1,000 psi)	19	
316L SST		01151-0041-0082
Alloy C-276		01151-0041-0083
Tantalum		01151-0041-0085
Range 8 AP (1,000 psia)	19	
316L SST		01151-0054-0082
Alloy C-276		01151-0054-0083
Range 9 GP (3,000 psig)	19	
316L SST		01151-0112-0092
Alloy C-276		01151-0112-0093
Range 10 GP (6,000 psig)	19	
316L SST		01151-0112-0002
Alloy C-276		01151-0112-0003

Sensor Modules (Inert Fill)—One spare part recommended for every 50 transmitters.		
Part Description	Item No.	Part Number
Range 3 DP, GP (30 in H₂O)	19	
316L SST		01151-0230-0032
Alloy C-276		01151-0230-0033
Tantalum		01151-0230-0035
Range 4 DP, GP (150 in H₂O)	19	
316L SST		01151-0230-0042
Alloy C-276		01151-0230-0043
Tantalum		01151-0230-0045
Range 5 DP, GP (750 in H₂O)	19	
316L SST		01151-0230-0052
Alloy C-276		01151-0230-0053
Tantalum		01151-0230-0055
Range 6 DP, GP (100 psi)	19	
316L SST		01151-0230-0062
Alloy C-276		01151-0230-0063
Tantalum		01151-0230-0065
Range 7 DP, GP (300 psi)	19	
316L SST		01151-0230-0072
Alloy C-276		01151-0230-0073
Tantalum		01151-0230-0075
Range 8 DP, GP (1,000 in psi)	19	
316L SST		01151-0230-0082
Alloy C-276		01151-0230-0083
Tantalum		01151-0230-0085

Housings, Covers, Flanges, And Valves – One spare part recommended for every 25 transmitters.		
Part Description	Item No.	Part Number
Electronics Housing Kit⁽¹⁾	7	
Aluminum		01151-0060-0007
SST		01151-0060-0023
Electronics Cover	1	
Aluminum		01151-1045-0001
SST		01151-0620-0001
Transient Protection	7	
Electronics Housing (Aluminum) for R1 Option without Terminal Block		01151-2594-0001
Electronics Housing (SST) for R1 Option without Terminal Block		01151-2594-0004
Transient Terminal Block Assembly (Optional R1)		01151-2591-0003
Transient Protection Retrofit Kit		01151-2630-0001
Process Flange	17	
Nickel-plated Carbon Steel		01151-0236-0005
316 SST		01151-0213-0002
Cast C-276		01151-0213-0004
Process Flange for Single Side Drain/Vent Valve		
Nickel-plated Carbon Steel		01151-0236-0015
316 SST		01151-0213-0012
Cast C-276		01151-0213-0014
Blank Flange	23	
Nickel-plated Carbon Steel		90043-0046-0002
Flange Adapter	21	
Nickel-plated Carbon Steel		01151-0211-0005
316 SST		01151-0211-0002
Cast C-276		01151-0211-0004
DP and HP Valve Stem and Seat, 316 SST ⁽²⁾	14,15	01151-0028-0022
GP and AP Valve Stem and Seat, 316 SST ⁽¹⁾	14,15	01151-0028-0012
DP and HP Valve Stem and Seat, Alloy C-276 ⁽¹⁾	14,15	01151-0028-0023
GP and AP Valve Stem and Seat, Alloy C-276 ⁽¹⁾	14,15	01151-0028-0013
Plug, 316 SST (used with side drain/vent)		C50246-0002
Plug, Alloy C-276 (used with side drain/vent)		01151-0063-0001

(1) Kit includes electronics housing and terminal block only. Order electronics cover separately.
(2) Package contains quantity required for one transmitter.

Hardware—One spare part recommended for every 50 transmitters.		
Part Description	Item No.	Part Number
Adjustment Kit		01151-0029-0001
Adjustment Screw	10	
O-ring for Adjustment Screw	11	
Retaining Ring	12	
O-ring for Adjustment Screw (pkg of 12)	11	01151-0032-0001
O-ring for Electronics Cover (pkg of 12)	2	01151-0033-0003
O-ring for Process Flange, Viton (pkg of 12)	18	01151-0034-0020
O-ring for Process Flange, Viton and Backup Ring (pkg of 4)	18	01151-0034-0014
O-ring for Process Flange, Buna-N (pkg of 12)	18	01151-0034-0002
O-ring for Process Flange, Buna-N and Backup Ring (pkg of 4)	18	01151-0034-0016
O-ring for Process Flange, Ethylene-propylene (pkg of 12)	18	01151-0034-0004
O-ring for Process Flange, Ethylene-propylene and Backup Ring (pkg of 4)	18	01151-0034-0015
O-ring for Process Flange, Aflas (pkg of 4) ⁽¹⁾	18	01151-0034-0019
O-ring for Process Flange, PTFE with Alloy C-276 Spring, W6 Option (pkg of 4)	18	01151-0034-0021
O-ring for Process Flange, PTFE, W7 Option (pkg of 12)	18	01151-0034-0003
O-ring for Flange Adapter, Viton (pkg of 12)	20	01151-0035-0009
O-ring for Flange Adapter, Buna-N (pkg of 12)	20	01151-0035-0002
O-ring for Flange Adapter, Ethylene-propylene (pkg of 12)	20	01151-0035-0004
O-ring for Flange Adapter, Aflas (pkg of 12) ⁽²⁾	20	01151-0035-0008
O-ring for Flange Adapter, PTFE, W6 and W7 Option (pkg of 12)	20	01151-0035-0003

(1) Kit contains enough parts for two differential or four gage/absolute transmitters. Backup rings are included.
(2) Part number is for package of 12 O-rings—only two required per transmitter.

Hardware (continued)—One spare part recommended for every 50 transmitters.		
Part Description	Item No.	Part Number
Electronics Assembly Hardware⁽¹⁾		01151-0030-0001
Standoff	8	
Standoff	5	
Screw	9	
Screw	3	
Locknut		
DP and HP Flange Kits, Carbon Steel⁽¹⁾		01151-0031-0001
Bolt for Flange Adapter	22	(DP & HP Ranges 3–5) or
Bolt for Process Flange	13	01151-0031-0034
Nut for Process Flange	16	(DP Ranges 6–8, HP Ranges 6–7)
GP and AP Flange Kits, Carbon Steel⁽¹⁾		01151-0031-0002
Bolt for Flange Adapter, Carbon Steel	22	(AP Ranges 4–5,
Bolt for Process Flange, Carbon Steel	13	GP Ranges 3–5)
Nut for Process Flange, Carbon Steel	16	or
		01151-0031-0035
		(AP & GP Ranges 6–8)
		or
		01151-0031-0003
		(GP Range 9)
		or
		01151-0031-0019
		(GP Range 0)
DP and HP Flange Kits, 316 SST⁽¹⁾		01151-0031-0023
Bolt for Flange Adapter	22	(DP & HP Ranges 3–5) or
Bolt for Process Flange	13	01151-0031-0038
Nut for Process Flange	16	(DP Ranges 6–8, HP Ranges 6–7)
GP and AP Flange Kits, 316 SST⁽¹⁾		01151-0031-0024
Bolt for Flange Adapter, 316 SST	22	(AP Ranges 4–5,
Bolt for Process Flange, 316 SST	13	GP Ranges 3–5)
Nut for Process Flange, 316 SST	16	or
		01151-0031-0039
		(AP & GP Ranges 6–8)
		or
		01151-0031-0025
		(GP Range 9)
		or
		01151-0031-0026
		(GP Range 0)
DP and HP Flange Kits, ANSI 193-B7⁽¹⁾		01151-0031-0012
Bolt for Flange Adapter	22	(DP & HP Ranges 3–5) or
Bolt for Process Flange	13	01151-0031-0036
Nut for Process Flange	16	(DP Ranges 6–8, HP Ranges 6–7)
GP and AP Flange Kits, ANSI 193-B7⁽¹⁾		01151-0031-0013
Bolt for Flange Adapter, ANSI 193-B7	22	(AP Ranges 4–5,
Bolt for Process Flange, ANSI 193-B7	13	GP Ranges 3–5)
Nut for Process Flange, ANSI 193-B7	16	or
		01151-0031-0037
		(AP & GP Ranges 6–8)
		or
		01151-0031-0014
		(GP Range 9)
		or
		01151-0031-0022
		(GP Range 0)

(1) Package contains quantity required for one transmitter.

Indicating Displays (Select approved meter kits for use in intrinsically safe and /or Type N installations)		
Part Description	Item No.	Part Number
Display Kits (includes LCD display, hardware, and housing cover assembly)		
Analog Display Kit, 4–20 mA dc, Linear Scale	NA	01151-1046-0007
Analog Display Kit, 4–20 mA dc, Square Root, 0-100% Flow		01151-1046-0009
Analog Display Kit, 10–50 mA dc, Linear Scale		01151-1046-0011
Analog Display Kit, 10–50 mA dc, Square Root, 0–100% Flow		01151-1046-0013
Approved Analog Display Kit, 4–20 mA dc, Linear Scale		01151-2615-0007
Approved Analog Display Kit, 4–20 mA dc, Square Root, 0-100% Flow		01151-2615-0009
Approved Analog Display Kit, 10–50 mA dc, Linear Scale		01151-2615-0011
Approved Analog Display Kit, 10–50 mA dc, Square Root, 0–100% Flow		01151-2615-0013
LCD Display Kit, Linear, 0–100%		01151-1046-0019
LCD Display Kit, Square Root, 0–100% Flow		01151-1046-0021
Displays Only		
Analog Display, 4–20 mA dc, Linear Scale		01151-0687-0004
Analog Display, 4–20 mA dc, Square Root, 0–100% Flow		01151-0687-0005
Analog Display, 4–20 mA dc, Square Root, 0–10 $\sqrt{\quad}$		01151-0687-0008
Analog Display, 10–50 mA dc, Linear Scale		01151-0687-0006
Analog Display, 10–50 mA dc, Square Root, 0–100% Flow		01151-0687-0007
Analog Display, 10–50 mA dc, Square Root, 0–10 $\sqrt{\quad}$		01151-0687-0009
Approved Analog Display, 4–20 mA dc, Linear Scale		01151-2614-0004
Approved Analog Display, 4–20 mA dc, Square Root, 0–100% Flow		01151-2614-0005
Approved Analog Display, 4–20 mA dc, Square Root, 0–10 $\sqrt{\quad}$		01151-2614-0008
Approved Analog Display, 10–50 mA dc, Linear Scale		01151-2614-0006
Approved Analog Display, 10–50 mA dc, Square Root, 0–100% Flow		01151-2614-0007
Approved Analog Display, 10–50 mA dc, Square Root, 0–10 $\sqrt{\quad}$		01151-2614-0009
LCD Display, Linear, 0–100%		01151-1300-1000
LCD Display, Square Root, 0–100% Flow		01151-1300-1001
LCD Display, Special Configuration ⁽¹⁾		See note (1) below
Display Hardware		
LCD Display Engineering Unit Labels		01151-1419-0001
Mounting Hardware and Cover Assembly Kit		01151-1046-0005
Mounting Hardware Kit		01151-1046-0006
Housing Cover Assembly Kit		01151-1047-0001
O-ring for Cover (pkg of 12)		01151-0033-0003
Mounting Brackets		
Part Description	Item No.	Part Number
B1—Right-angle Bracket for 2-in. Pipe Mounting	NA	01151-0036-0001
B2—Right-angle Bracket for Panel Mounting		01151-0036-0004
B3—Flat Bracket for 2-in. Pipe Mounting		01151-0036-0005
B4—Bracket for 2-in. Pipe with Series 316 SST Bolts		01151-0036-0003
B5—Bracket for Panel with Series 316 SST Bolts		01151-0036-0006
B6—Flat Bracket for 2-in. Pipe with Series 316 SST Bolts		01151-0036-0007
B7—316 SST B1 Bracket with 316 SST Bolts		01151-0036-0021
B9—316 SST B3 Bracket with 316 SST Bolts		01151-0036-0022

(1) To order a display with a special configuration, order the appropriate display and indicate configuration required. Since this is not a kit, order the mounting hardware and housing cover assembly separately.

Figure A-2. Rosemount 1151 Analog Pressure Transmitter Exploded View.

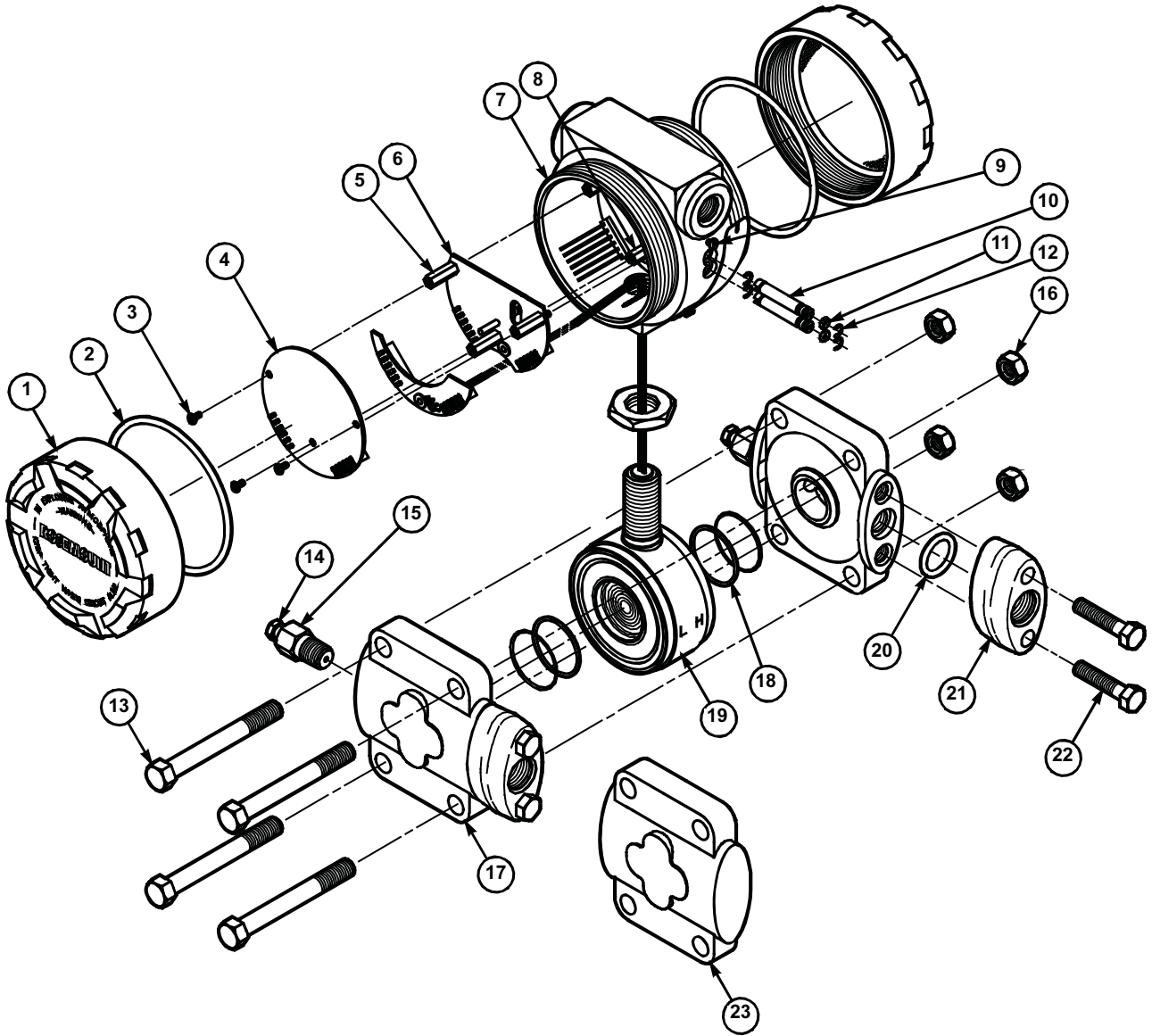

1151LT PARTS LIST

Item numbers are references to figure callouts (page A-33 and page A-34).

Rosemount 1151

Figure A-3. Rosemount 1151 Smart Pressure Transmitter Exploded View.

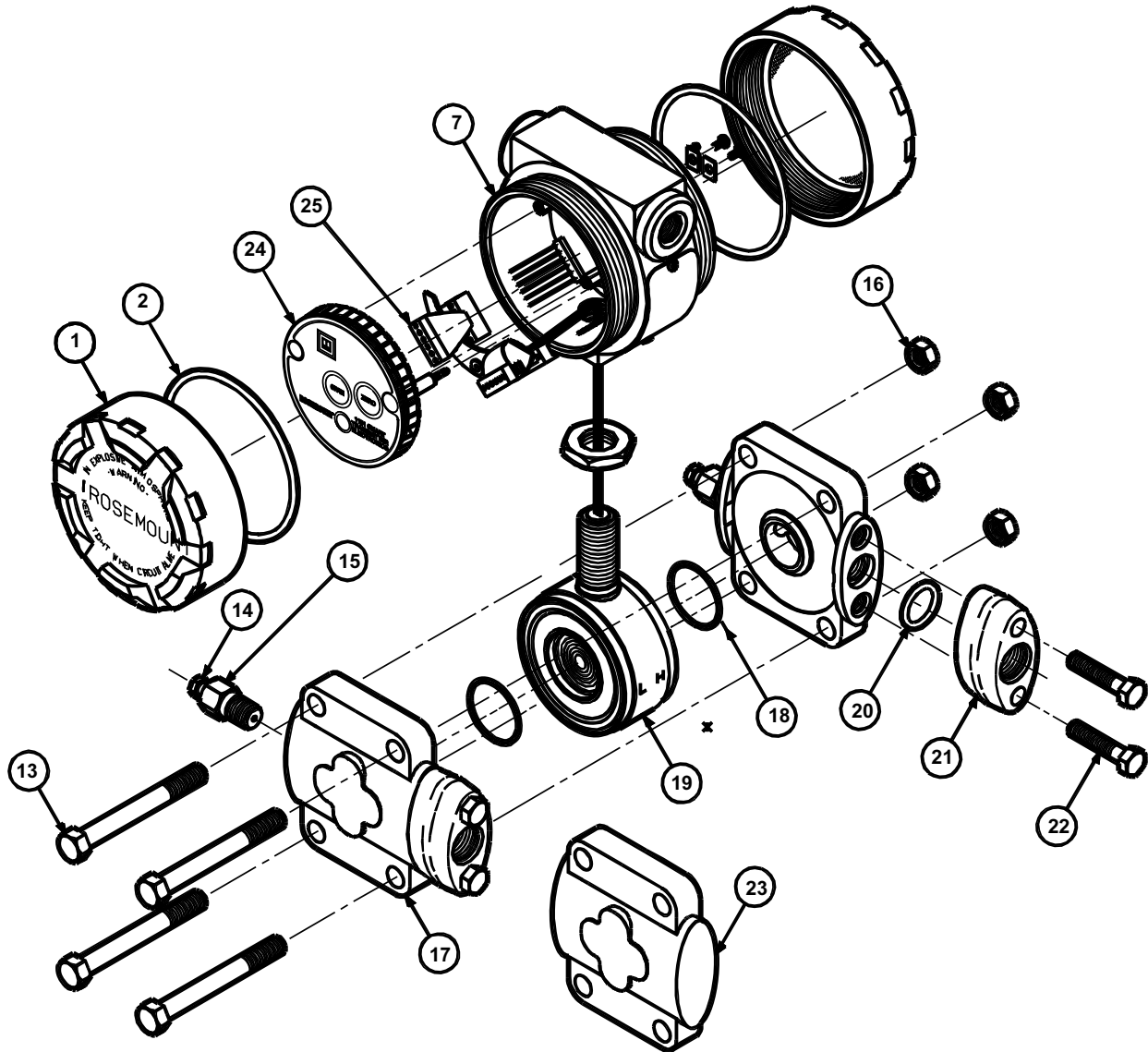

Table A-12. Rosemount 1151LT Flange-Mounted Liquid Level Pressure Transmitter.

Part Description	Item No.	Part Number	Spares Category ⁽¹⁾
Diaphragm and Sensor Module Assembly	13	See Note Below	B
Flange Adapter			
316 SST	21	01151-0211-0002	
Cast C-276		01151-0211-0004	
Valve Stem and Seat, 316 SST	18, 19	01151-0028-0012	
Plug, 316 SST (used with side drain/vent)		C50246-0002	A
Valve Stem and Seat, Alloy C-276	18, 19	01151-0028-0013	
Plug, Alloy C-276 (used with side drain/vent)		C50246-0202	A
Bolt for Flange Adaptor			
316 SST	20	01151-0031-0024	
ANSI 193-B7	20	01151-0031-0013	
O-ring for Flange Adapter			
Viton (pkg of 12)	22	01151-0035-0009	
Buna-N (pkg of 12)	22	01151-0035-0002	
Aflas (pkg of 12)	22	01151-0035-0008	
Ethylene-Prop. (pkg of 12)	22	01151-0035-0004	
PTFE (pkg of 12)	22	01151-0035-0003	
SMART OUTPUT CODE – See next page for details	—	01151-0935-0001	B
Electronics Housing (Aluminum)	7	01151-0060-0007	
Electronics Cover (Aluminum)	1	01151-1045-0001	
Adjustment Screw, Retaining Ring, and O-ring for Adjustment Screw Kit	10, 11, 12	01151-0029-0001	
O-ring for Electronics Cover ⁽¹⁾	2	01151-0033-0003	
Electronics Assembly Hardware			
Standoff			
Standoff	8	01151-0030-0001	
Screw	5		
Screw	9		
Locknut	3		
Output Code, 4-20 mA dc			
Amplifier Circuit Board	4	01151-0137-0007	E
Calibration Circuit Board	6	01151-0139-0001	
Output Code, 10-50 mA dc			
Amplifier Circuit Board	4	01151-0597-0001	G
Calibration Circuit Board	6	01151-0139-0001	

(1) Rosemount recommends one spare part for every 25 transmitters in Category A, and one spare part for every 50 transmitters in Category B.

NOTE

The Diaphragm and Sensor Module Assembly is an oil filled system and must be serviced using the proper equipment. Contact your nearest Emerson Process Management service facility should it become necessary to replace or service this assembly.

S Output Code (Smart) Part/Kit Description	Item No.	Part Number
Smart Retrofit Kit ⁽¹⁾		01151-0935-0001
Smart Transmitter Electronics ⁽²⁾	24	01151-0948-0203
Board Spacer Kit (pkg of 12)	25	01151-0813-0001
Terminal Eyelet Kit (pkg of 12)		01151-0814-0001
Standoff Kit (pkg of 12)		01151-0815-0001
Cover ⁽²⁾		01151-1045-0001
Cover O-ring (pkg of 12)		01151-0033-0003

Indicating Displays Part Description	Part Number
Display Kits (includes LCD display, hardware, and housing cover assembly)	
Analog Display Kit, 4–20 mA dc, Linear Scale	01151-1046-0007
Analog Display Kit, 10–50 mA dc, Linear Scale	01151-1046-0011
Approved Analog Display Kit, 4–20 mA dc, Linear Scale	01151-2615-0007
Approved Analog Display Kit, 10–50 mA dc, Linear Scale	01151-2615-0011
LCD Display Kit, Linear, 0–100%	01151-1046-0019
Displays Only	
Analog Display, 4–20 mA dc, Linear Scale	01151-0687-0004
Analog Display, 10–50 mA dc, Linear Scale	01151-0687-0006
Approved Analog Display, 4–20 mA dc, Linear Scale	01151-2614-0004
Approved Analog Display, 10–50 mA dc, Linear Scale	01151-2614-0006
LCD Display, Linear, 0–100%	01151-1300-1000
LCD Display, Special Configuration ⁽³⁾	See note (3) below
Display Hardware	
LCD Display Engineering Unit Labels	01151-1419-0001
Mounting Hardware and Cover Assembly Kit	01151-1046-0005
Mounting Hardware Kit	01151-1046-0006
Housing Cover Assembly Kit	01151-1047-0001
O-ring for Cover (pkg of 12)	01151-0033-0003

(1) Kit contains enough parts for one transmitter and includes the smart transmitter electronics, board spacers, terminal eyelets, standoffs, cover, and cover O-rings.

(2) Kit contains enough parts for one transmitter.

(3) To order a display with a special configuration, order the appropriate display and indicate configuration required. Since this is not a kit, order the mounting hardware and housing cover assembly separately.

Figure A-4. Rosemount 1151LT Smart Pressure Transmitter Exploded View.

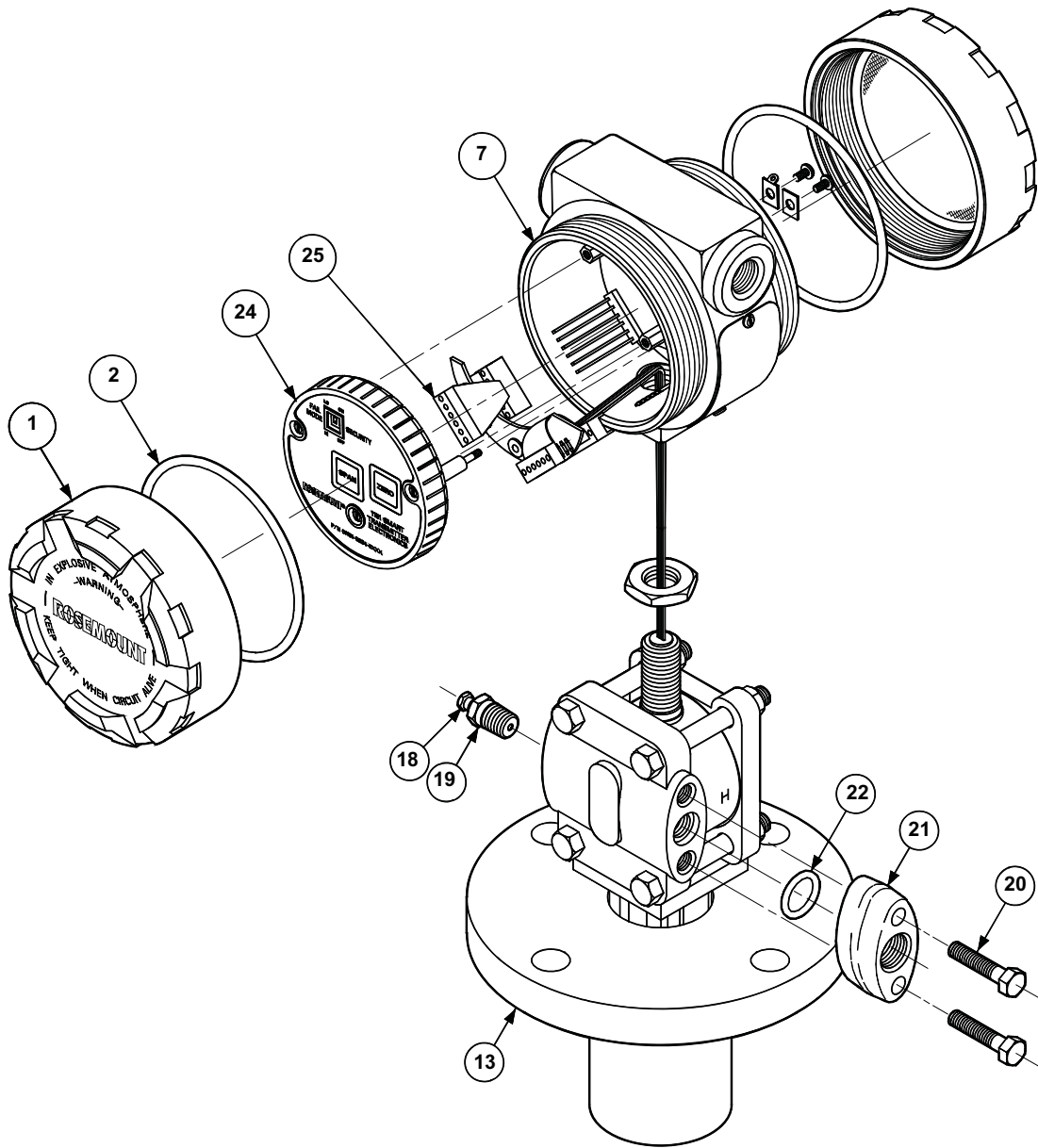
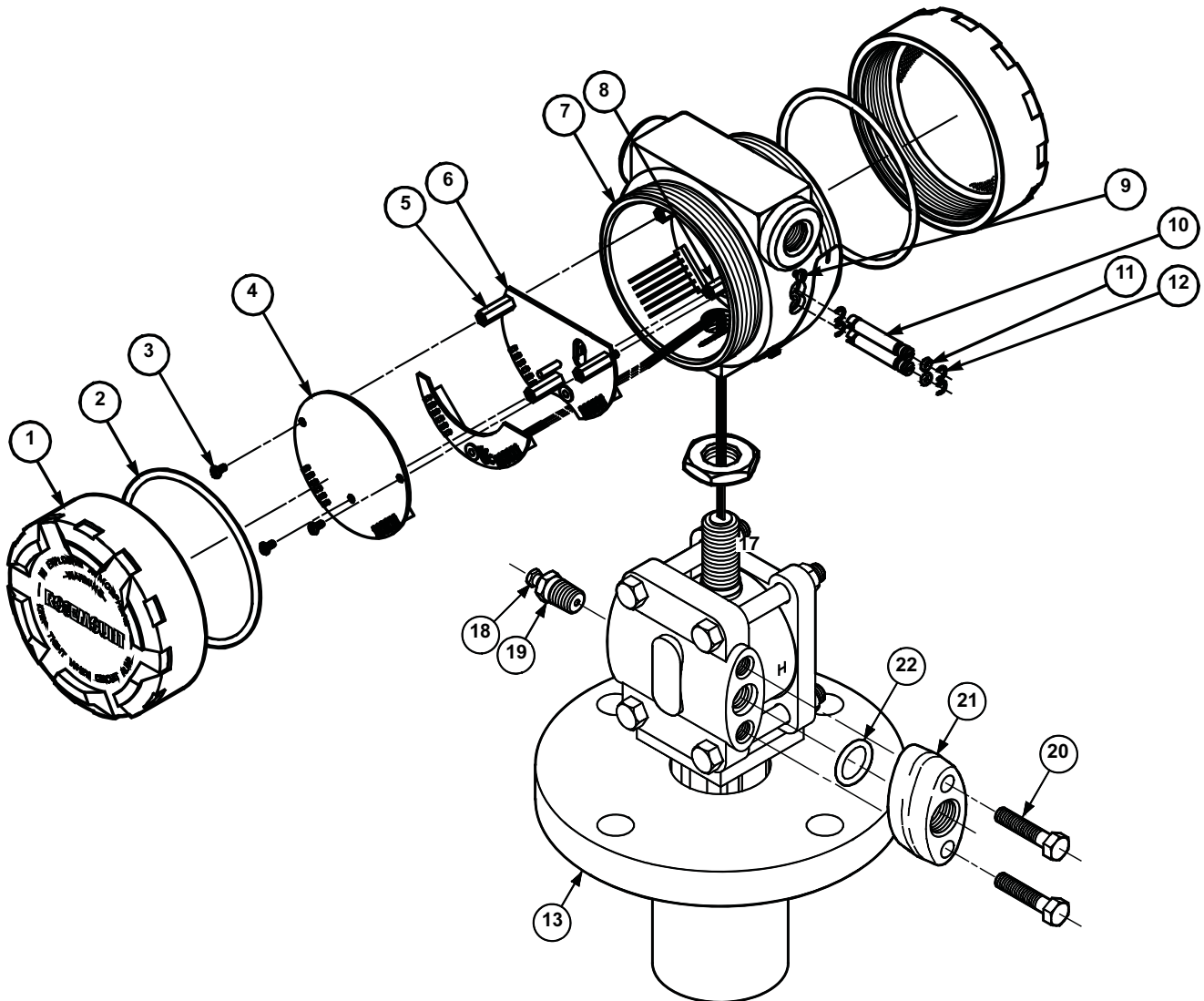

Figure A-5. Rosemount 1151LT Analog Pressure Transmitter Exploded View.



DISPLAY SPECIFICATIONS

Analog

- Meters have 2-in. (50.8 mm) scale
- Plug-in mounting configuration
- Indication accuracy $\pm 2\%$
- Operating temperature limit: -40 to 150 °F (-40 to 65 °C)
- Meters are enclosed in a housing certified by Factory Mutual as Explosion-Proof for Class I, Division 1, Groups B, C, and D; Class II, Division 1, Groups E, F, and G and Class III, Division 1
- For optional CSA explosion-proof approval, see certification Option Code E6
- M1 Linear Analog Meter, 0–100% Scale
- M2 Square Root Analog Meter, 0–100% Flow Scale
- M6 Square Root Analog Meter, 0– $10\sqrt{\quad}$ Scale

LCD

- 4-digit display
- Indication accuracy $\pm 0.25\%$ of calibrated span ± 1 digit
- Display resolution at $\pm 0.5\%$ of calibrated span ± 1 digit
- Operating temperature limit: -4 to 158 °F (-20 to 70 °C)
- Plug-in mounting configuration
- Meters are enclosed in a housing certified by FM as Explosion-Proof for Class I, Division 1, Groups B, C, and D; Class II, Division 1, Groups E, F, and G and Class III, Division 1
- For Optional CSA explosion-proof approval, see certification Option Code E6
- M4 Linear LCD Meter, 0 to 100%
- M7 Special Scale LCD Meter
 - Specify:
 - Range (20 mA value must be greater than 4 mA value)
 - Mode
 - Engineering Units
- M8 Square Root LCD Meter, 0 to 100% Flow
- M9 Square Root LCD Meter, 0– $10\sqrt{\quad}$ Scale

NOTES

Meter Options are not available with Output Codes L or M, or Option Codes V2 or V3. Meter Options M4, M7, M8, and M9 are not available with Output Code G.

Appendix B Product Certifications

Approved Manufacturing Locations	page B-1
European Directive Information	page B-1
Hazardous Locations Certifications	page B-2
Approval Drawings	page B-4

APPROVED MANUFACTURING LOCATIONS

Rosemount Inc. — Chanhassen, Minnesota, USA
Emerson Process Management GmbH & Co. — Wessling, Germany
Emerson Process Management Asia Pacific
Private Limited — Singapore
Beijing Rosemount Far East Instrument Co., Limited – Beijing, China

EUROPEAN DIRECTIVE INFORMATION

The EC declaration of conformity for all applicable European directives for this product can be found on the Rosemount website at www.rosemount.com. A hard copy may be obtained by contacting our local sales office.

ATEX Directive (94/9/EC)

Emerson Process Management complies with the ATEX Directive.

European Pressure Equipment Directive (PED) (2004/108/EC)

1151GP9, 0; 1151HP4, 5, 6, 7, Pressure Transmitters

— QS Certificate of Assessment - EC No. PED-H-100
Module H Conformity Assessment

All other 1151 Pressure Transmitters

— Sound Engineering Practice

Transmitter Attachments: Diaphragm Seal - Process Flange - Manifold

— Sound Engineering Practice

Electro Magnetic Compatibility (EMC) (2004/108/EC)

All models

— EN 61326-1: 1997 with Amendments A1, A2, and A3;

Rosemount 1151

HAZARDOUS LOCATIONS CERTIFICATIONS

North American Certifications

Ordinary Location Certification for Factory Mutual

As standard, the transmitter has been examined and tested to determine that the design meets basic electrical, mechanical, and fire protection requirements by FM, a nationally recognized testing laboratory (NRTL) as accredited by the Federal Occupational Safety and Health Administration (OSHA).

Factory Mutual (FM) Approvals

FM Explosion-Proof tag is standard. Appropriate tag will be substituted if optional certification is selected.

Explosion-Proof: Class I, Division 1, Groups B, C, and D. Dust-Ignition Proof: Class II, Division 1, Groups E, F, and G; Class III, Division 1. Indoor and outdoor use. NEMA 4X. Factory Sealed.

- I5 Intrinsically safe for Class I, II, and III Division 1, Groups A, B, C, D, E, F, and G hazardous locations in accordance with entity requirements and Control drawing 01151-0214 and 00268-0031. Non- incendive for Class I, Division 2, Groups A, B, C and D hazardous locations.

For entity parameters see control drawing 01151-0214.

Canadian Standards Association (CSA) Approvals

- E6 Explosion-Proof for Class I, Division 1, Groups C and D; Class II, Division 1, Groups E, F, and G; Class III, Division 1 Hazardous Locations. Suitable for Class I, Division 2, Groups A, B, C, and D; CSA enclosure type 4X. Factory Sealed.
- I6 Intrinsically safe for Class I, Division 1, Groups A, B, C, and D hazardous locations when connected per Drawing 01151-2575. For entity parameters see control drawing 01151-2575. Temperature Code T2D.

European Certifications

- I1 ATEX Intrinsically Safe and Combustible Dust (1151 Smart only)
Certificate No.: BAS99ATEX1294X
ATEX Marking Ⓜ II 1 GD
EEx ia IIC T5 (-60°C ≤ Ta ≤ 40°C)
EEx ia IIC T4 (-60°C ≤ Ta ≤ 80°C)
cE 1180
IP66

Table B-1. IS Entity Parameters

Ui = 30 V
Ii = 125 mA
Pi = 1.0 W (T4) or 0.67 W (T5)
Ci = 0.034 μF
Li = 20 μH

Special Conditions for Safe Use (x):

The apparatus, is not capable of withstanding the 500V test as required by EN 50020: 1994. This must be taken into account when installing the apparatus.

- N1 ATEX Type n and Combustible Dust
(1151 Smart only)
Certificate No.: BAS 99ATEX3293X
ATEX marking:  II 3 GD
EEx nL IIC T5 (-40°C ≤ Ta ≤ 40°C)
EEx nL IIC T4 (-40°C ≤ Ta ≤ 80°C)
Dust Rating: T90 °C (Ta = -20°C to 40°C)
U_i = 45 Vdc Max
CE
IP66

Special Conditions for Safe Use (x):

The apparatus is not capable of withstanding the 500V insulation test required by EN 50021: 1999. This must be taken into account when installing the apparatus.

- E8 ATEX Flame-Proof
Certification Number CESI03ATEX037
ATEX Marking  II 1/2 G
EEx d IIC T6 (-40 ≤ Ta ≤ 40 °C)
EEx d IIC T4 (-40 ≤ Ta ≤ 80 °C)
CE 1180
V = 60 Vdc maximum

Australian Certifications

Standards Association of Australia (SAA) Certification

- E7 SAA Flame-proof
Certificate Number Ex 494X
Ex d IIB + H₂ T6
DIP T6
IP65

Special Conditions for safe use (x):

For transmitters having NPT, PG or G cable entry threads, an appropriate flame-proof thread adaptor shall be used to facilitate application of certified flame-proof cable glands or conduit system.

- I7 SAA Intrinsically Safe
Certificate Number: Ex 122X
Ex ia IIB T5 (T_{amb} = 40 °C)
Ex ia IIB T4 (T_{amb} = 80 °C)

Special Conditions for Safe Use (x):

The equipment has been assessed to the entity concept and accordingly the following electrical parameters must be taken into account during installation.

Table B-2. Entity Parameters

$U_i = 30V$
$I_i = 125\text{ mA}$
$P_i = 1.0\text{ W (T4) or } 0.67\text{ W (T5)}$
$C_i = 14.8\text{ nF}$
$L_i = 20\text{ }\mu\text{H}$

- N7 SAA Type n
 Certificate Number: Ex 887X
 Ex n IIC T6 ($T_{amb} = 40\text{ }^\circ\text{C}$)
 Ex n IIC T5 ($T_{amb} = 80\text{ }^\circ\text{C}$)
 IP66

Special Conditions for safe use (x):

The equipment must be connected to a supply voltage which does not exceed the rated voltage. The enclosure end caps must be correctly fitted whilst the equipment is energized.

Combination Certifications

Stainless steel certification tag is provided when optional approval is specified. Once a device labeled with multiple approval types is installed, it should not be reinstalled using any other approval types. Permanently mark the approval label to distinguish it from unused approval types.

- C6 Combination of I6 and E6,
- K5 Combination of FM Approvals Explosion-Proof and I5.
- K6 Combination of E6, I6, I1, and E8

APPROVAL DRAWINGS

Index of intrinsically safe barrier systems and entity parameters for Rosemount 1151 transmitters and Rosemount 751 Field Indicators (Drawing Number 01151-0214, Rev. V), pages B-5 through B-10.

Index of intrinsically safe C.S.A. barrier systems for Rosemount 1151 transmitters (Drawing Number 01151-2575, Rev. C), pages B-11 through B-13.

Index of intrinsically safe barrier systems and entity parameters for the HART Communicator SMART FAMILY Interface (Drawing Number 00268-0031, Rev M), pages B-14 through B-20.

Index of intrinsically safe barrier systems and entity parameters for the HART Communicator (Drawing Number 00275-0081, Rev B), pages B-21 through B-26.

Index of intrinsically safe C.S.A. barrier systems for the HART Communicator (Drawing Number 00275-0082, Rev A), page B-27.

Index of intrinsically safe barrier systems and entity parameters for the HART Communicator (Drawing Number 00375-1130, Rev B), page B-27 through page B-31.

Figure B-1.

REVISIONS						
LTR	DESCRIPTION	ECO NO	REV BY	APPR	DATE	
P	Change entity parameters (Fm on re-exam) correct 444 CI	637376	WCR	WCR	9/28/90	
R	Add 1151 Low Power Barrier System, Model 751 LI to 0	638105		WCR	4/27/90	
T	1135, 1144, 1151 LI TO ϕ	639039	SVC	WCR	1/23/91	
U	1151 LI TO 20; CI .01 AND .034	651426	SVC	WCR	12/11/92	
V	751 LI TO ϕ	662242		QSE	1/17/94	

CONTENTS	
ENTITY APPROVALS	SHEETS 2 THRU 4
APPROVED PARAMETERS	SHEETS 2 THRU 3
CONNECTION DIAGRAMS	SHEET 4

MASTER

APPROVED SOURCES OF SUPPLY	
MFG	MFG PART NO

Material purchased to this Rosemount Specification Control Drawing shall be required to meet all the specifications of this drawing. Any mention of manufacturer's part number within this drawing is for reference only. This is necessary to ensure design control of Rosemount's end product. It is Rosemount's intent to purchase your standard material whenever possible.

SPECIFICATION CONTROL DRAWING

UNLESS OTHERWISE SPECIFIED, DIMENSIONS ARE IN INCHES. TOLERANCES: DECIMALS FRACTIONS .X ± .1 ± 1/32 .XX ± .02 ANGLES .XXX ± .010 ± 2°	PREPARED BY: <i>Nancy Nix</i>	DATE: 9/28/90	ROSEMOUNT [®] Measurement Control Analytical Valves	
	CHECKED BY: <i>WCR</i>	APPROVED BY Q.C.		TITLE INDEX OF INTRINSICALLY SAFE BARRIER SYSTEMS & ENTITY PARAMETERS FOR 444, 1135, 1144, 1151, & 2051 TRANSMITTERS AND 751 FIELD INDICATORS
	APPROVED BY ENG. <i>R. C. Karnst</i>	APPROVED BY PURCH.		SIZE CODE IDENT NO DRAWING NO A 04274 01151-0214
	APPROVED BY PURCH.	FINAL APPROVAL ES		SCALE None U/M: Each SHEET 1 OF 5
	APPROVED BY PURCH.	FINAL APPROVAL ES		SCALE None U/M: Each SHEET 1 OF 5

ENTITY CONCEPT APPROVALS

The entity concept allows interconnection of intrinsically safe apparatus to associated apparatus not specifically examined in combination as a system. The approved values of maximum open circuit voltage (V_{OC} or V_T) and maximum short circuit current (I_{SC} or I_T) for the associated apparatus must be less than or equal to the maximum safe input voltage (V_{MAX}) and input current (I_{MAX}) of the intrinsically safe apparatus. In addition, the approved maximum allowable connected capacitance (C_A) and inductance (L_A) of the associated apparatus must be greater than the maximum unprotected internal capacitance (C_I) and inductance (L_I) of the intrinsically safe apparatus. The approved entity concept parameters are as follows:

Model 444

Class I, Div. 1, Groups A and B

$V_{MAX} = 40V$
 $I_{MAX} = 165\text{ mA}$
 $C_I = 0.044\mu F$
 $L_I = 0$

V_{OC} or V_T is less than or equal to 40V
 I_{SC} or I_T is less than or equal to 165 mA
 C_A is greater than 0.044IF
 L_A is greater than 0

Class I, Div. 1, Groups C and D

$V_{MAX} = 40V$
 $I_{MAX} = 225\text{ mA}$
 $C_I = 0.044\mu F$
 $L_I = 0$

V_{OC} or V_T is less than or equal to 40V
 I_{SC} or I_T is less than or equal to 225 mA
 C_A is greater than 0.044IF
 L_A is greater than 0

Model 751

Class I, Div. 1, Groups A and B

$V_{MAX} = 40V$
 $I_{MAX} = 165\text{ mA}$
 $C_I = 0$
 $L_I = 0$

V_{OC} or V_T is less than or equal to 40V
 I_{SC} or I_T is less than or equal to 165 mA
 C_A is greater than 0
 L_A is greater than 0

Class I, Div. 1, Groups C and D

$V_{MAX} = 40V$
 $I_{MAX} = 225\text{ mA}$
 $C_I = 0$
 $L_I = 0$

V_{OC} or V_T is less than or equal to 40V
 I_{SC} or I_T is less than or equal to 225 mA
 C_A is greater than 0
 L_A is greater than 0

REVISION

Rosemount Inc. MINNEAPOLIS, MINNESOTA		SIZE A	FSCM. NO.	DRAWING NO. 01151-0214
DR.		SCALE: NONE	WT.	SHEET 2 OF 6
ISSUE				

MASTER

Model and 1151

Class I, Div. 1, Groups A and B

$V_{MAX} = 40V$
 $I_{MAX} = 165\text{ mA}$
 $C_I(1151\text{ Std}) = 0$
 $C_I(\text{Smart } 1151) = 0.024\mu F$
 $C_I(1151\text{ Std w/R Option}) = 0.010\mu F$
 $C_I(1151\text{ Smart w/R_Option}) = 0.034\mu F$
 $L_I(1151\text{ Std}) = 0$
 $L_I(1151\text{ w/R_Option}) = 20\mu H$

V_{OC} or V_T is less than or equal to 40V
 I_{SC} or I_T is less than or equal to 165 mA
 C_A is greater than 0
 C_A is greater than $0.024\mu F$
 C_A is greater than $0.010\mu F$
 C_A is greater than $0.034\mu F$
 L_A is greater than 0
 L_A is greater than $20\mu H$

Class I, Div. 1, Groups C and D

$V_{MAX} = 40V$
 $I_{MAX} = 225\text{ mA}$
 $C_I(1151\text{ Std}) = 0$
 $C_I(\text{Smart } 1151) = 0.024\mu F$
 $C_I(1151\text{ Std w/R Option}) = 0.010\mu F$
 $C_I(1151\text{ Smart w/R_Option}) = 0.034\mu F$
 $L_I(1151\text{ Std}) = 0$
 $L_I(1151\text{ w/R_Option}) = 20\mu H$

V_{OC} or V_T is less than or equal to 40V
 I_{SC} or I_T is less than or equal to 225 mA
 C_A is greater than 0
 C_A is greater than $0.024\mu F$
 C_A is greater than $0.010\mu F$
 C_A is greater than $0.034\mu F$
 L_A is greater than 0
 L_A is greater than $20\mu H$

Model 2051

Class I, Div. 1, Groups A and B

$V_{MAX} = 40V$
 $I_{MAX} = 165\text{ mA}$
 $C_I = 0.012\mu F$
 $L_I = 480\mu H$

V_{OC} or V_T is less than or equal to 40V
 I_{SC} or I_T is less than or equal to 165 mA
 C_A is greater than $0.012\mu F$
 L_A is greater than $480\mu H$

Class I, Div. 1, Groups C and D

$V_{MAX} = 40V$
 $I_{MAX} = 225\text{ mA}$
 $C_I = 0.012\mu F$
 $L_I = 480\mu H$

V_{OC} or V_T is less than or equal to 40V
 I_{SC} or I_T is less than or equal to 225 mA
 C_A is greater than $0.012\mu F$
 L_A is greater than $480\mu H$

Rosemount Inc. MINNEAPOLIS, MINNESOTA		SIZE	FSCM. NO.	DRAWING NO.
		A		01151-0214
DR.		SCALE: NONE	WT.	SHEET 3 OF 6
ISSUE				

Model 1135

Class I, Div. 1, Groups A and B

$V_{MAX} = 40V$
 $I_{MAX} = 165\text{ mA}$
 $C_I = 0.008\mu F$
 $L_I = 0$

V_{OC} or V_T is less than or equal to 40V
 I_{SC} or I_T is less than or equal to 165 mA
 C_A is greater than 0.0081F
 L_A is greater than 0

Class I, Div. 1, Groups C and D

$V_{MAX} = 40V$
 $I_{MAX} = 225\text{ mA}$
 $C_I = 0.008\mu F$
 $L_I = 0$

V_{OC} or V_T is less than or equal to 40V
 I_{SC} or I_T is less than or equal to 225 mA
 C_A is greater than 0.0081F
 L_A is greater than 0

Model 1144

Class I, Div. 1, Groups A and B

$V_{MAX} = 40V$
 $I_{MAX} = 165\text{ mA}$
 $C_I = 0$
 $L_I = 0$

V_{OC} or V_T is less than or equal to 40V
 I_{SC} or I_T is less than or equal to 165 mA
 C_A is greater than 0
 L_A is greater than 0

Class I, Div. 1, Groups C and D

$V_{MAX} = 40V$
 $I_{MAX} = 225\text{ mA}$
 $C_I = 0$
 $L_I = 0$

V_{OC} or V_T is less than or equal to 40V
 I_{SC} or I_T is less than or equal to 225 mA
 C_A is greater than 0
 L_A is greater than 0

MASTER

Rosemount Inc. MINNEAPOLIS, MINNESOTA		SIZE A	FSCM. NO.	DRAWING NO. 01151-0214
DR.		SCALE: NONE	WT.	SHEET 4 OF 6
ISSUE				

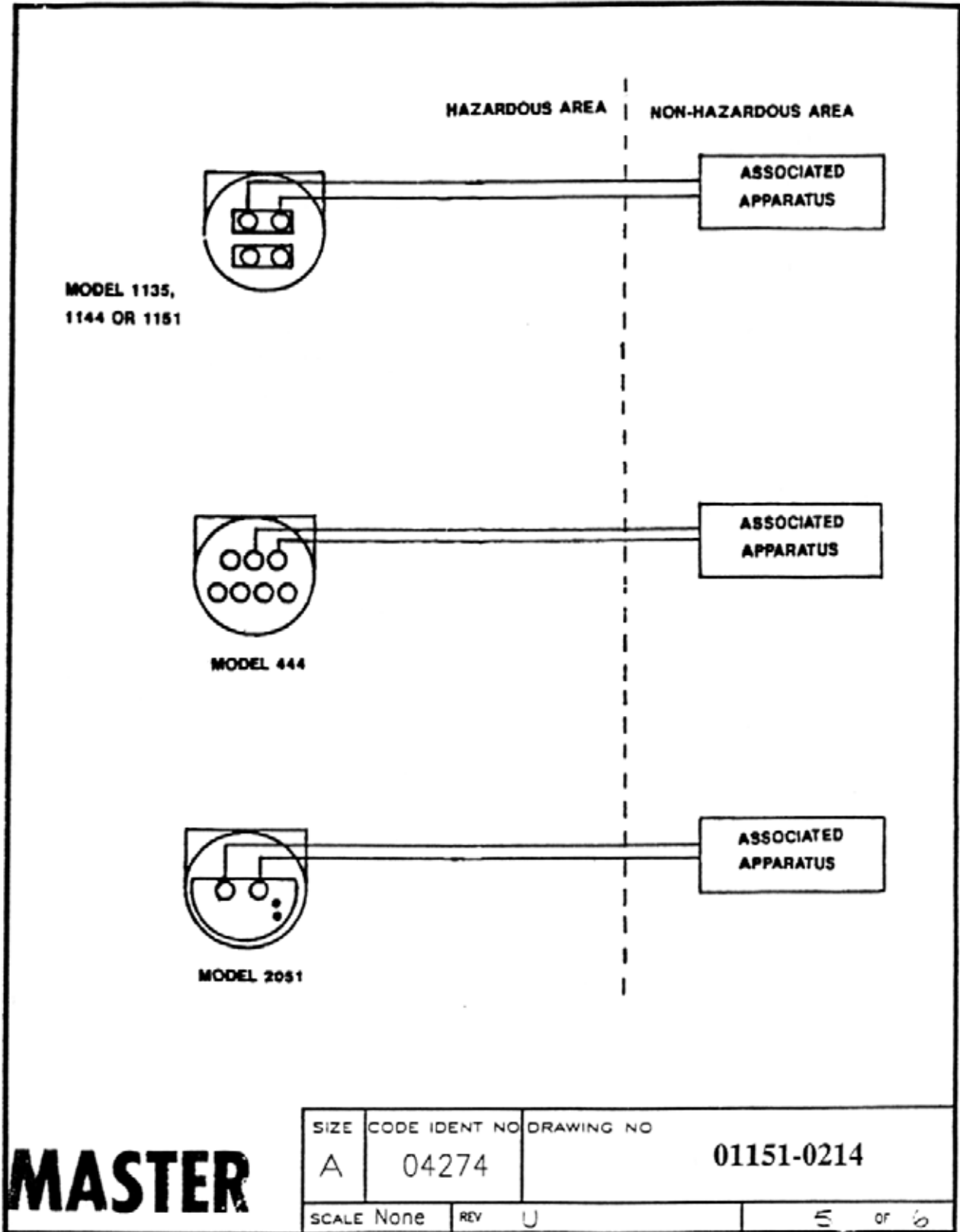

MASTER

SIZE	CODE IDENT NO	DRAWING NO
A	04274	01151-0214
SCALE None	REV U	5 of 6

1151 --- L & M CIRCUIT CONNECTION WITH INTRINSIC SAFETY BARRIERS

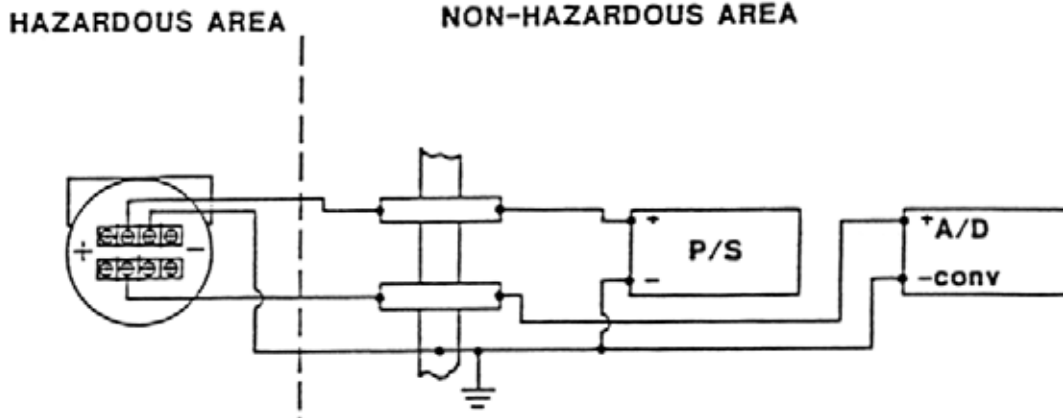

CIRCUIT DIAGRAM 1
 (ONLY FOR USE WITH BARRIERS APPROVED IN THIS CONFIGURATION)

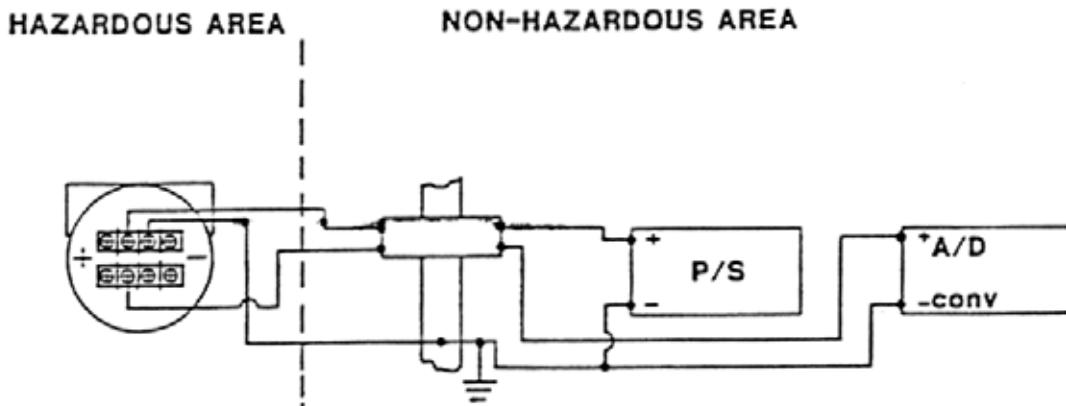

CIRCUIT DIAGRAM 2

MASTER

SIZE	CODE IDENT NO	DRAWING NO
A	04274	01151-0214
SCALE	NONE	REV U
		c OF 6

Figure B-2.

BY _____ PROPRIETARY INFORMATION IS CONTAINED HEREIN AND MUST BE HANDLED ACCORDINGLY DATE _____	REVISIONS				
	REV	DESCRIPTION	CHG. NO.	APP'D	DATE
	A	NEW RELEASE	646666	W.C.R.	04/01/92
	B	150 ohms was 120 ohms	650816	J.J.B.	11/13/92
	C	150 ohms was 120 ohms (SHT 3)	652195	J.J.B.	1/29/93

CSA INTRINSICALLY SAFE APPROVAL

Exia
 Intrinsically Safe /Securite Inrinseque

THE ROSEMOUNT MODEL 1151 PRESSURE TRANSMITTER IS APPROVED BY CSA AS INTRINSICALLY SAFE FOR THE CLASS I, DIVISION 1 GROUPS AS INDICATED WHEN USED WITH THE BARRIERS AND CONVERTERS LISTED BELOW AND CONNECTED AS SHOWN IN THE ACCOMPANYING DIAGRAMS.

DEVICE	PARAMETERS	APPROVED FOR CLASS I, DIV. 1
CSA Approved Safety Barrier	<div style="font-size: 2em;">{</div> 30 V or less 330 ohms or more 28 V or less 300 ohms or more 22 V or less 180 ohms or more <div style="font-size: 2em;">}</div>	Groups A, B, C, D
Foxboro Converter 2AS-131-CGB, 3AD-131A CS-E /CGB-A, 2AI-13V-CGB, 3A2-13D CS-E /CGB-A, 2AI-12V-CGB, 3A2-12D CS-E /CGB-A, 2AS-121-CGB, 3A4-12DA CS-E /CGB-A, 3F4-12DA1 CS-E /CGB-A		Groups B, C, D
CSA Approved Safety Barrier	30 V or less 150 ohms or more	Groups C, D

THIS DRAWING WAS CREATED ON CAD. DRAWING IS ARCHIVED ON MAGNETIC TAPE FOR ECO CHANGES.

UNLESS OTHERWISE SPECIFIED DIMENSIONS IN INCHES. REMOVE ALL BURRS AND SHARP EDGES. MACHINE SURFACE FINISH 125 - TOLERANCES - DECIMALS FRACTIONS .X±.1 ±1/32 .XX±.02 ANGLES .XXX±.010 ±2° DO NOT SCALE PRINT	CONTRACT NO.	ROSEMOUNT ® Measurement Control Analytical Valves Rosemount Inc. 12001 Technology Drive Eden Prairie, MN 55344 USA TITLE INDEX OF CSA INTRINSICALLY SAFE BARRIER SYSTEMS FOR MODEL 1151 TRANSMITTERS SIZE A FSCM NO. DWG NO. 01151-2575 SCALE N/A WT. _____ SHEET 1 OF 3
	DR. S.CAPPAUL 03/18/92	
	CHK'D W.C.RAUTH 04/01/92	
	APP'D. W.C.RAUTH 04/01/92	
	APP'D. GOVT.	

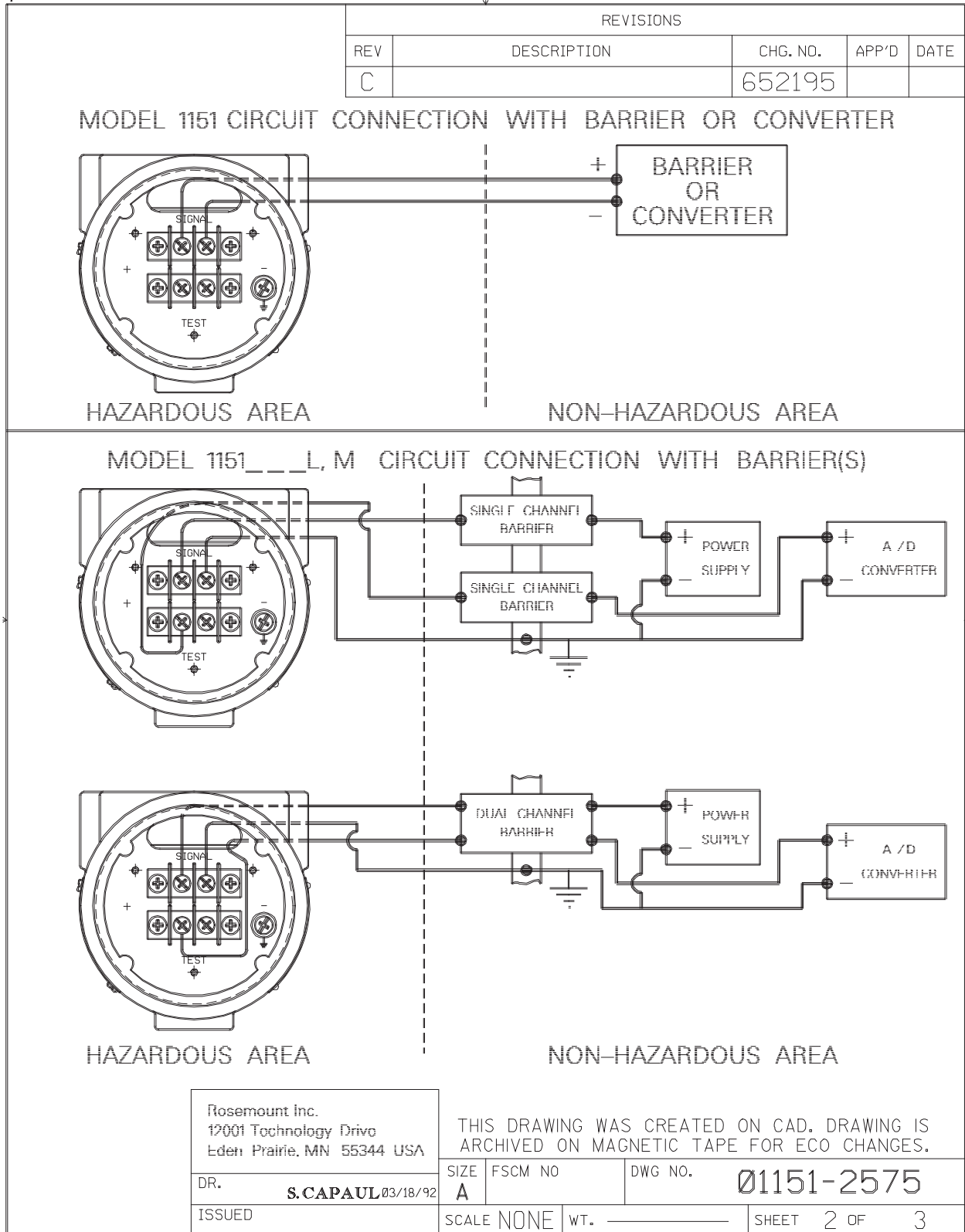

REVISIONS				
REV	DESCRIPTION	CHG. NO.	APP'D	DATE
C		652195		

MODEL 1151__L, M CIRCUIT CONNECTION WITH BARRIER(S)
 (CONTINUED)

APPROVED FOR CLASS I, DIVISION 1, GROUPS A, B, C, D WHEN USED IN CIRCUIT WITH TWO CSA APPROVED SINGLE CHANNEL SAFETY BARRIERS; ONE WITH APPROVED SAFETY PARAMETERS OF 28 VOLTS OR LESS AND 300 OHMS OR MORE IN +POWER LINE, AND THE OTHER WITH APPROVED SAFETY PARAMETERS OF 10 VOLTS OR LESS AND 47 OHMS OR MORE IN +OUTPUT LINE.

-OR-

ONE CSA APPROVED DUAL CHANNEL SAFETY BARRIER WITH IDENTICAL APPROVED SAFETY PARAMETERS CONNECTED IN LIKE MANNER.

APPROVED FOR CLASS I, DIVISION 1, GROUPS C, D WHEN USED IN CIRCUIT WITH TWO CSA APPROVED SINGLE CHANNEL SAFETY BARRIERS; ONE WITH APPROVED SAFETY PARAMETERS OF 30 VOLTS OR LESS AND 150 OHMS OR MORE IN +POWER LINE AND THE OTHER WITH APPROVED SAFETY PARAMETERS OF 10 VOLTS OR LESS AND 47 OHMS OR MORE IN +OUTPUT LINE.

Rosemount Inc.
 12001 Technology Drive
 Eden Prairie, MN 55344 USA

THIS DRAWING WAS CREATED ON CAD. DRAWING IS ARCHIVED ON MAGNETIC TAPE FOR ECO CHANGES.

DR.	S. CAPAUL	03/30/92	SIZE A	FSCM NO	DWG NO. Ø1151-2575
ISSUED			SCALE N/A	WT.	SHEET 3 OF 3

Rosemount 1151

Figure B-3.

PROPRIETARY INFORMATION IS CONTAINED HEREIN AND MUST BE HANDLED ACCORDINGLY		REVISIONS					
BY _____	DATE _____	REV	DESCRIPTION	CHG. NO.	APP'D	DATE	
		G	ADD SHT 4&5, DELETE CLASS II & III.	636328	B.S.J.	08/01/90	
		H	ADD 3051 P/L/H, 3001C CL /CH	636904	K.D.V.	09/06/90	
		J	ADD SHT. 6, FIX TBL. 1.	638723	B.S.J.	01/02/91	
		K	ADD 3044C	641710	W.R.K.	06/13/91	
		L	ADD 3001S & SHT 7 FOR 3051C-LP	642380	G.E.M.	8/13/91	
		M	ADD 3095	653145	K.D.V.	4/8/93	
<p>THE ROSEMOUNT MODEL 268 SMART FAMILY INTERFACE IS APPROVED BY FACTORY MUTUAL AS INTRINSICALLY SAFE FOR THE CLASS I, DIVISION 1 GROUPS INDICATED WHEN USED IN CIRCUIT WITH THE BARRIERS AND CONVERTERS LISTED BELOW AND THE ROSEMOUNT SMART FAMILY TRANSMITTERS DEPICTED IN THE ACCOMPANYING CIRCUIT DIAGRAMS.</p>							
BARRIER MANUFACTURER	MODEL	APPROVED FOR CLASS I DIVISION 1, GROUPS					
FOXBORO	2AI-12V-FGB 2AI-13V-FGB 2AS-13I-FGB 3A2-12D-CS-E/FGB-A 3A2-13D-CS-E/FGB-A	A,B,C,D					
HONEYWELL	38545-000-0110-113-F5B5 38545-000-0110-111/112-F5B5	C,D					
MTL	115 122 322 715 722	A,B,C,D					
R. STAHL	8901/31-199/100/7 8901/30-199/100/7 8901/31-280/165/7 8901/30-280/165/7 [8903/51-200/050/7 8901/31-086/150/7 [8901/31-280/165/7 8901/31-086/150/7 9005/01-245/060 9005/01-252/100	C,D C,D A,B,C,D A,B,C,D C,D C,D A,B,C,D A,B,C,D					
TAYLOR	5850FL81200 5851FL81200 1130FF21000 1130FF22000 1135FF21000 1135FF22000	C,D					
THIS DRAWING WAS CREATED ON CAD. DRAWING IS ARCHIVED ON MAGNETIC TAPE FOR ECO CHANGES.							
<small>UNLESS OTHERWISE SPECIFIED DIMENSIONS IN INCHES. REMOVE ALL BURRS AND SHARP EDGES. MACHINE SURFACE FINISH 125 - TOLERANCES - DECIMALS FRACTIONS .X±.1 ±1/32 .XX±.02 ANGLES .XXX±.010 ±2° DO NOT SCALE PRINT</small>	CONTRACT NO.		ROSEMOUNT ® <small>Measurement Control Analytical Valves</small>				
	DR. MIKE DOBE 2/7/90		TITLE INDEX OF I.S. BARRIER SYSTEMS FOR MOD. 268 SMART FAMILY INTERFACE				
	CHK'D						
	APP'D. K. CARLSON 03/13/90		SIZE A	FSCM NO	DWG NO.	00268-0031	
	APP'D. GOVT.		SCALE	WT.	SHEET 1 OF 7		

FORM NO. 60651A-1 REV. C

REVISIONS				
REV	DESCRIPTION	CHG. NO.	APP'D	DATE
M		653145		
<p>ENTITY CONCEPT APPROVALS</p> <p>THE ENTITY CONCEPT ALLOWS INTERCONNECTION OF INTRINSICALLY SAFE APPARATUS TO ASSOCIATED APPARATUS NOT SPECIFICALLY EXAMINED IN COMBINATION AS A SYSTEM. THE APPROVED VALUES OF MAXIMUM OPEN CIRCUIT VOLTAGE (V_T OR V_{OC}) AND MAXIMUM SHORT CIRCUIT CURRENT (I_T OR I_{SC}) AND MAXIMUM OUTPUT POWER ($\frac{V_{OC} \times I_{SC}}{4}$ OR $\frac{V_T \times I_T}{4}$), FOR THE ASSOCIATED APPARATUS MUST BE LESS THAN OR EQUAL TO THE MAXIMUM SAFE INPUT VOLTAGE (V_{MAX}), MAXIMUM SAFE INPUT CURRENT (I_{MAX}) AND MAXIMUM SAFE INPUT POWER (P_{MAX}) OF THE INTRINSICALLY SAFE APPARATUS. IN ADDITION, THE APPROVED MAXIMUM ALLOWABLE CONNECTED CAPACITANCE (C_A) AND INDUCTANCE (L_A) OF THE ASSOCIATED APPARATUS MUST BE GREATER THAN THE MAXIMUM UNPROTECTED INTERNAL CAPACITANCE (C_1) AND INDUCTANCE (L_1) OF THE INTRINSICALLY SAFE APPARATUS. THE APPROVED ENTITY CONCEPT PARAMETERS ARE AS FOLLOWS:</p> <p style="text-align: center;">NOTE: ENTITY PARAMETERS LISTED APPLY ONLY TO ASSOCIATED APPARATUS WITH LINEAR OUTPUT.</p>				
INPUT PARAMETERS (CLASS I, DIV. 1, GROUPS A, B, C, D)				
$V_{max} = 32 \text{ Vdc}$		V_T or V_{oc} of barrier must be $\leq 32 \text{ Vdc}$		
$I_{max} = 186 \text{ mA}$		I_T or I_{sc} of barrier must be $\leq 186 \text{ mA}$		
$C_1 = 0.01 \mu\text{F}$		C_A of barrier must be $\geq 0.01 \mu\text{F}$		
$L_1 = 1.1 \text{ mH}$		L_A of barrier must be $\geq 1.1 \text{ mH}$		
P_{max} :	1.1W	0.8W	0.6W	$\frac{V_{oc} \times I_{sc}}{4}$ of barrier must be \leq specified value.
Temp code	T4A	T5	T6	
OUTPUT PARAMETERS				
$V_{oc} = 1.5 \text{ Vd.c.}$				
$I_{sc} = 27 \text{ mA}$				
$C_A = 10,000 \mu\text{F}$				
$L_A = 46 \text{ mH}$				
Rosemount Inc. 12001 Technology Drive Eden Prairie, MN 55344 USA		THIS DRAWING WAS CREATED ON CAD. DRAWING IS ARCHIVED ON MAGNETIC TAPE FOR ECO CHANGES.		
DR.	D.PEARSON	SIZE A	FSCM NO.	DWG NO. 00268-0031
ISSUED		SCALE N/A	WT. _____	SHEET 2 OF 7

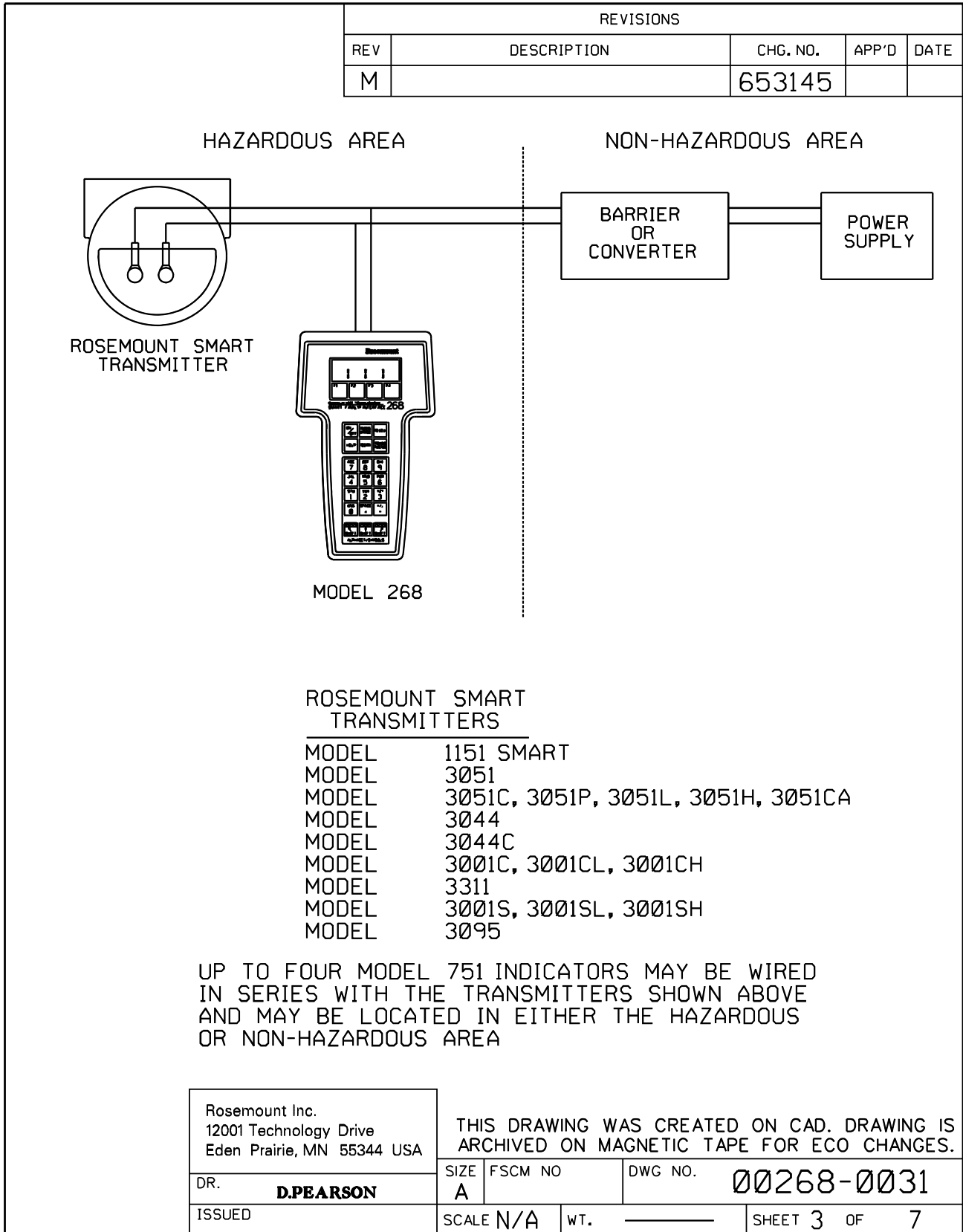

REVISIONS				
REV	DESCRIPTION	CHG. NO.	APP'D	DATE
M		653145		

THE MAXIMUM ALLOWABLE CONNECTED INDUCTANCE (L_a) OF THE ASSOCIATED APPARATUS IS DETERMINED BY ADDING 27 mA TO THE I_{sc} OF THE BARRIER ($I_m = I_{sc} + 27\text{mA}$) AND ENTERING TABLE 1 (SHT 5) AT THE RESULTING VALUE, I_m , OR THE NEXT HIGHER VALUE OF I_m , TO DETERMINE THE L_a , (THE L_a MUST INCLUDE THE L_1 OF THE MODEL 268, WHICH IS 1.1mH).

EXAMPLE #1: I_{sc} OF BARRIER = 100mA.
 $I_m = 100\text{mA} + 27\text{mA} = 127\text{mA}$
 ENTER TABLE AT $I_m = 130\text{mA}$; $L_a = 2.0\text{mH}$

--WARNING-- BEFORE CONNECTING THE MODEL 268 INTO THE LOOP, DETERMINE THE CONNECTED INDUCTANCE OF THE SYSTEM BY ADDING THE L_1 OF THE TRANSMITTER, CABLE, AND MODEL 268. THE SUM MUST BE LESS THAN THE L_a DETERMINED FROM THE TABLE IN ORDER FOR THE MODEL 268 TO BE CONNECTED INTO THE LOOP. IF THE CONNECTED INDUCTANCE IS GREATER THAN THE VALUE DETERMINED FROM THE TABLE, A BARRIER WITH A LOWER I_{sc} MUST BE CHOSEN.

EXAMPLE #2: BARRIER I_{sc} = 41.8mA; BARRIER L_a = 20.0mH
 $I_m = 41.8\text{mA} + 27\text{mA} = 68.8\text{mA}$;
 ENTER TABLE AT 70mA AND READ $L_a = 7.5\text{mH}$
 ADD CONNECTED INDUCTANCE OF SYSTEM:

MODEL 268	$L_1 = 1.1\text{mH}$
MODEL 3051 TRANSMITTER	$L_1 = 0.48\text{mH}$
INDUCTANCE OF LOOP WIRING	1.0mH

TOTAL CONNECTED INDUCTANCE	= 2.58mH

TOTAL CONNECTED INDUCTANCE IS LESS THAN $L_a = 7.5$ mH AS DETERMINED ABOVE AND IS ALSO LESS THAN THE BARRIER L_a . THE MODEL 268 MAY SAFELY BE CONNECTED INTO THE LOOP. IF THE MODEL 751 INDICATORS ARE USED, THEIR TOTAL INDUCTANCE (LABEL VALUE * NUMBER OF INDICATORS) MUST ALSO BE INCLUDED.

S.BARDUSON	30JUL90	SIZE	FSCM NO	DWG NO.	00268-0031
		A			
		SCALE	N/A	WT.	SHEET 4 OF 7

REVISIONS				
REV	DESCRIPTION	CHG. NO.	APP'D	DATE
M		653145		

I _m (mA)	L _o (mH)
150	1.3
145	1.5
140	1.6
130	2.0
120	2.5
110	3.0
100	4.0
90	5.0
85	5.5
80	6.0
75	6.7
70	7.5
65	8.8
62	9.5
60	10.0
57	11.0
55	12.0
50	15.0
45	19.0
40	23.0
35	31.0

TABLE 1

Rosemount Inc. 12001 Technology Drive Eden Prairie, MN 55344 USA	THIS DRAWING WAS CREATED ON CAD. DRAWING IS ARCHIVED ON MAGNETIC TAPE FOR ECO CHANGES.		
DR. S.BARDUSON 30JUL90	SIZE A	FSCM NO	DWG NO. 00268-0031
ISSUED	SCALE N/A	WT. _____	SHEET 5 OF 7

FORM NO. 60651A-1 REV. C

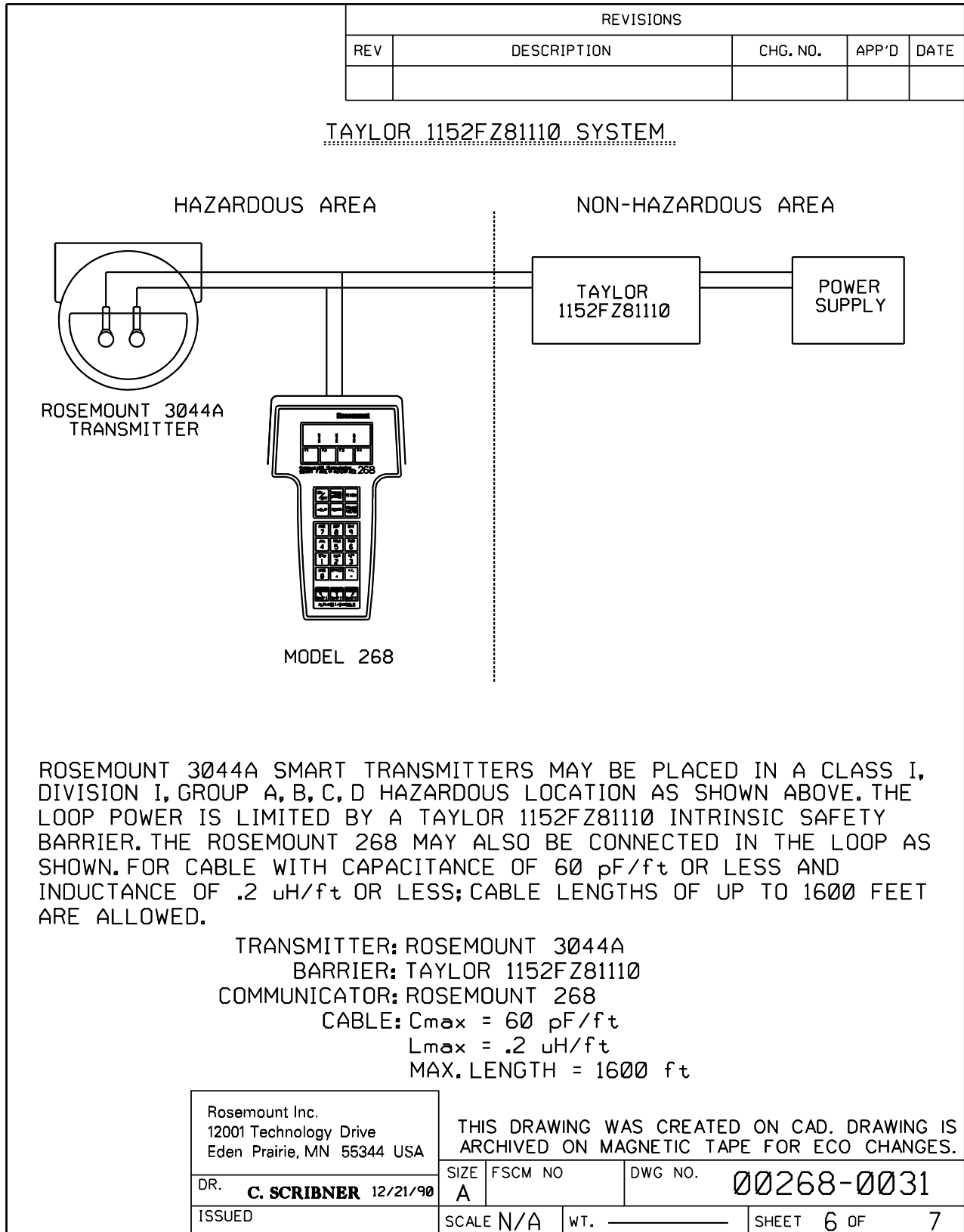

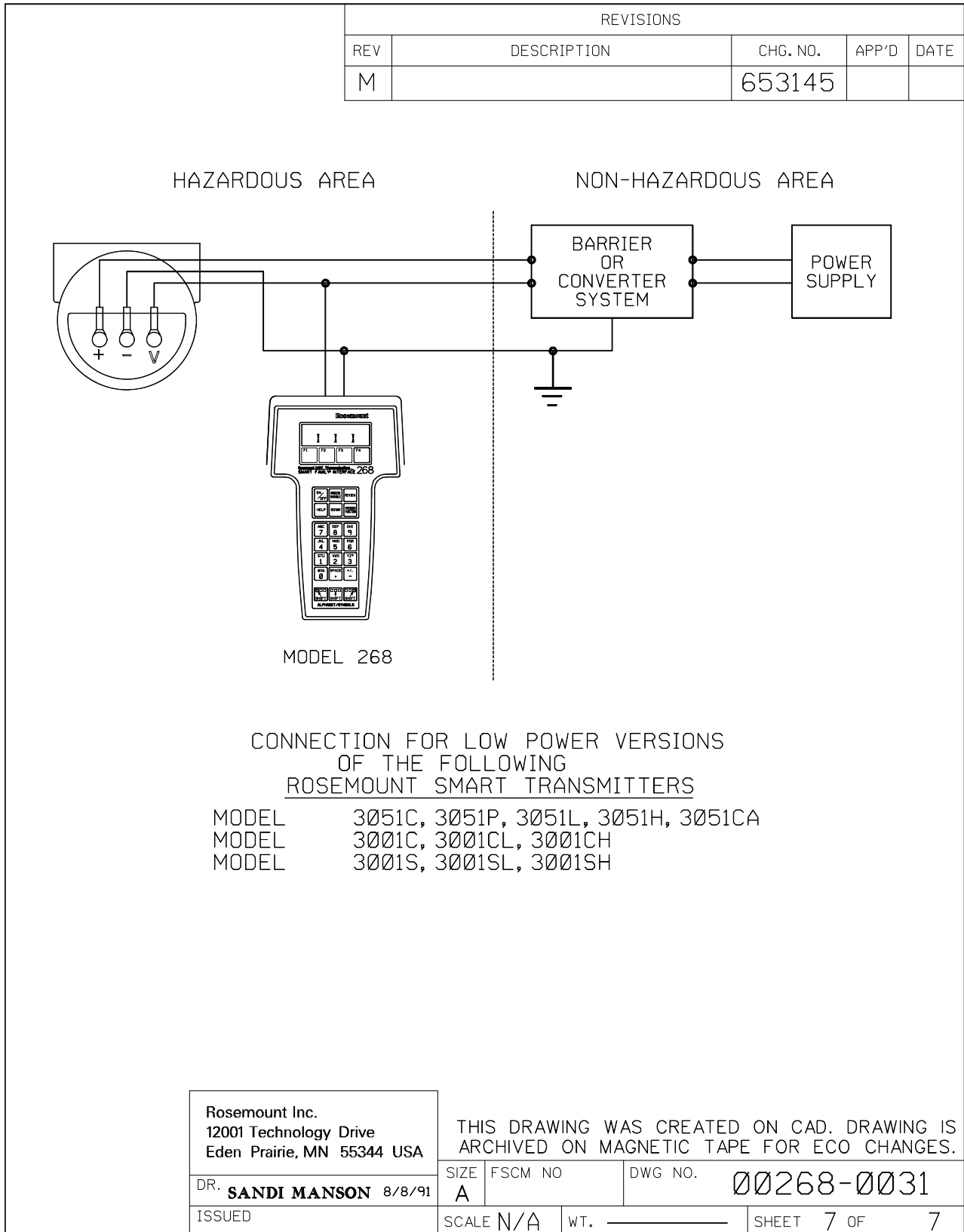

FORM NO. 60651A-1 REV. C

Figure B-4.

PROPRIETARY INFORMATION IS CONTAINED HEREIN AND MUST BE HANDLED ACCORDINGLY BY _____ DATE _____		REVISIONS				
		REV	DESCRIPTION	CHG. NO.	APP'D	DATE
		A	NEW RELEASE	654533	B.S.J.	8/30/93
		B	CHG V _{max} & C ₁	657178	B.S.J.	12/13/93
THIS DRAWING WAS CREATED ON CAD. DRAWING IS ARCHIVED ON MAGNETIC TAPE FOR ECO CHANGES.						
UNLESS OTHERWISE SPECIFIED DIMENSIONS IN INCHES. REMOVE ALL BURRS AND SHARP EDGES. MACHINE SURFACE FINISH 125 - TOLERANCES - DECIMALS FRACTIONS .X±.1 ±1/32 .XX±.02 ANGLES .XXX±.010 ±2° DO NOT SCALE PRINT	CONTRACT NO.		ROSEMOUNT ® Measurement Control Analytical Valves Rosemount Inc. 12001 Technology Drive Eden Prairie, MN 55344 USA			
	DR.	C. SCRIBNER 6/2/93				
	CHK'D					
	APP'D.	B.S. JUNK 8/30/93				
	APP'D. GOVT.					
		SIZE	FSCM NO	DWG NO.		
		A		00275-0081		
		SCALE	WT.	SHEET	1 OF 6	

REVISIONS																
REV	DESCRIPTION	CHG. NO.	APP'D	DATE												
B		657178														
<p>FM ENTITY CONCEPT APPROVALS</p> <p>THE ENTITY CONCEPT ALLOWS INTERCONNECTION OF INTRINSICALLY SAFE APPARATUS TO ASSOCIATED APPRATUS NOT SPECIFICALLY EXAMINED IN COMBINATION AS A SYSTEM. THE APPROVED VALUES OF MAXIMUM OPEN CIRCUIT VOLTAGE (V_T OR V_{OC}) AND MAXIMUM SHORT CIRCUIT CURRENT (I_T OR I_{SC}) FOR THE ASSOCIATED APPARATUS MUST BE LESS THAN OR EQUAL TO THE MAXIMUM SAFE INPUT VOLTAGE (V_{MAX}) AND MAXIMUM SAFE INPUT CURRENT (I_{MAX}) OF THE INTRINSICALLY SAFE APPARATUS, IN ADDITION, THE APPROVED MAXIMUM ALLOWABLE CONNECTED CAPACITANCE (C_A) AND INDUCTANCE (L_A) OF THE ASSOCIATED APPARATUS MUST BE GREATER THAN THE MAXIMUM UNPROTECTED INTERNAL CAPACITANCE (C_I) AND INDUCTANCE (L_I) OF THE INTRINSICALLY SAFE APPARATUS. THE APPROVED ENTITY CONCEPT PARAMETERS ARE AS FOLLOWS:</p> <p style="text-align: center;">NOTE: ENTITY PARAMETERS LISTED APPLY ONLY TO ASSOCIATED APPARATUS WITH LINEAR OUTPUT.</p>																
INPUT PARAMETERS (CLASS I, DIV. 1, GROUPS A, B, C, D)																
$V_{max} = 30 \text{ Vdc}$		V_T or V_{oc} of barrier must be $\leq 30 \text{ Vdc}$														
$I_{max} = 300 \text{ mA}$		I_T or I_{sc} of barrier must be $\leq 300 \text{ mA}$														
$C_1 = 0.07 \mu F$		C_A of barrier must be $\geq 0.07 \mu F$														
$L_1 = 0 \text{ mH}$		L_A of barrier must be $\geq 0 \text{ mH}$														
OUTPUT PARAMETERS																
$V_{oc} = 1.7 \text{ Vd.c.}$																
$I_{sc} = 32 \text{ mA}$																
<table border="1" style="width: 100%; border-collapse: collapse;"> <tr> <td style="width: 40%; padding: 5px;"> Rosemount Inc. 12001 Technology Drive Eden Prairie, MN 55344 USA </td> <td style="padding: 5px;"> THIS DRAWING WAS CREATED ON CAD. DRAWING IS ARCHIVED ON MAGNETIC TAPE FOR ECO CHANGES. </td> </tr> <tr> <td style="padding: 5px;"> DR. C.SCRIBNER </td> <td style="padding: 5px;"> <table border="1" style="width: 100%; border-collapse: collapse;"> <tr> <td style="width: 15%;">SIZE A</td> <td style="width: 25%;">FSCM NO</td> <td style="width: 60%;">DWG NO. 00275-0081</td> </tr> </table> </td> </tr> <tr> <td style="padding: 5px;">ISSUED</td> <td style="padding: 5px;"> <table border="1" style="width: 100%; border-collapse: collapse;"> <tr> <td style="width: 20%;">SCALE N/A</td> <td style="width: 20%;">WT. _____</td> <td style="width: 60%;">SHEET 2 OF 6</td> </tr> </table> </td> </tr> </table>					Rosemount Inc. 12001 Technology Drive Eden Prairie, MN 55344 USA	THIS DRAWING WAS CREATED ON CAD. DRAWING IS ARCHIVED ON MAGNETIC TAPE FOR ECO CHANGES.	DR. C.SCRIBNER	<table border="1" style="width: 100%; border-collapse: collapse;"> <tr> <td style="width: 15%;">SIZE A</td> <td style="width: 25%;">FSCM NO</td> <td style="width: 60%;">DWG NO. 00275-0081</td> </tr> </table>	SIZE A	FSCM NO	DWG NO. 00275-0081	ISSUED	<table border="1" style="width: 100%; border-collapse: collapse;"> <tr> <td style="width: 20%;">SCALE N/A</td> <td style="width: 20%;">WT. _____</td> <td style="width: 60%;">SHEET 2 OF 6</td> </tr> </table>	SCALE N/A	WT. _____	SHEET 2 OF 6
Rosemount Inc. 12001 Technology Drive Eden Prairie, MN 55344 USA	THIS DRAWING WAS CREATED ON CAD. DRAWING IS ARCHIVED ON MAGNETIC TAPE FOR ECO CHANGES.															
DR. C.SCRIBNER	<table border="1" style="width: 100%; border-collapse: collapse;"> <tr> <td style="width: 15%;">SIZE A</td> <td style="width: 25%;">FSCM NO</td> <td style="width: 60%;">DWG NO. 00275-0081</td> </tr> </table>	SIZE A	FSCM NO	DWG NO. 00275-0081												
SIZE A	FSCM NO	DWG NO. 00275-0081														
ISSUED	<table border="1" style="width: 100%; border-collapse: collapse;"> <tr> <td style="width: 20%;">SCALE N/A</td> <td style="width: 20%;">WT. _____</td> <td style="width: 60%;">SHEET 2 OF 6</td> </tr> </table>	SCALE N/A	WT. _____	SHEET 2 OF 6												
SCALE N/A	WT. _____	SHEET 2 OF 6														

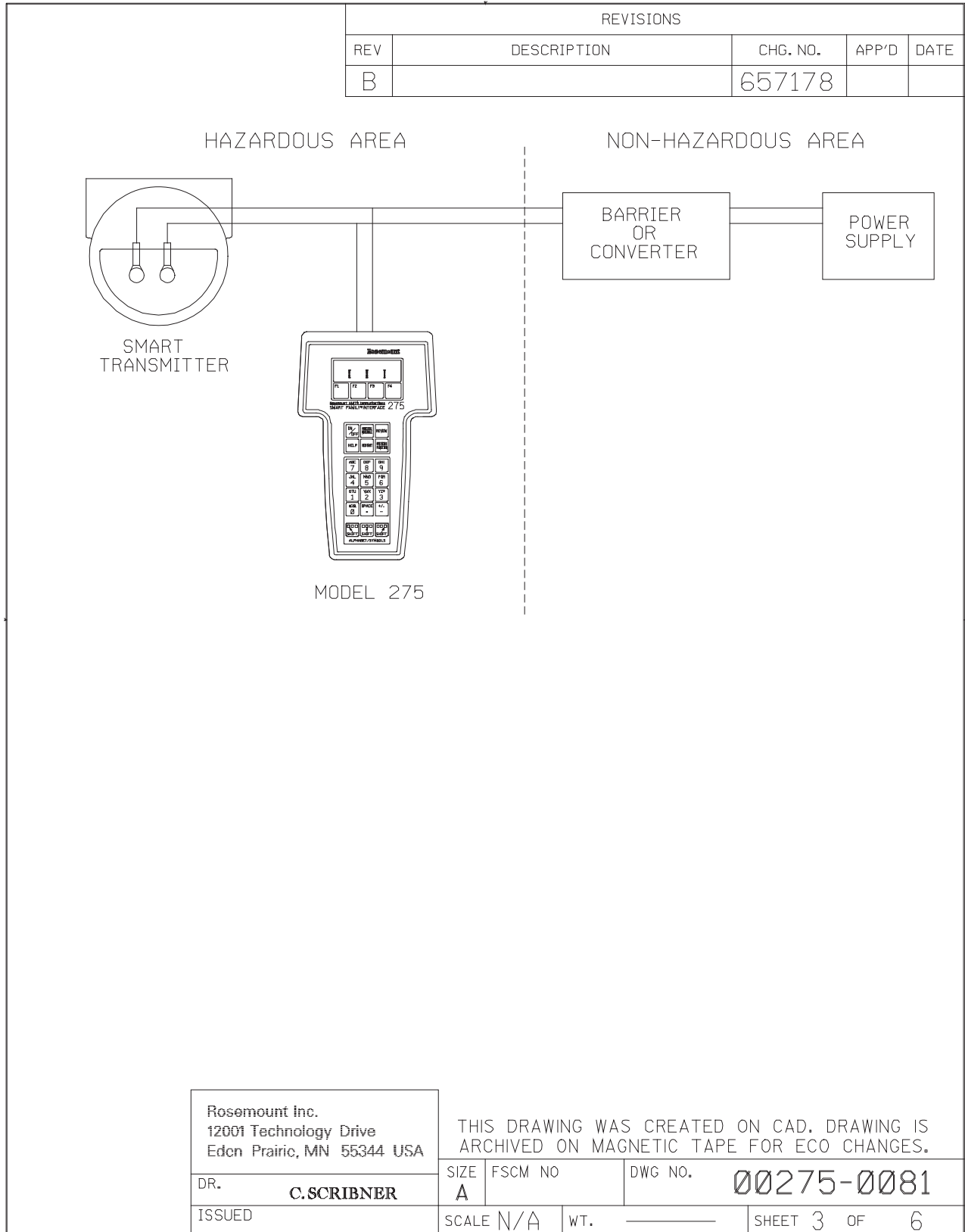

Rosemount Inc.
 12001 Technology Drive
 Eden Prairie, MN 55344 USA

DR. **C. SCRIBNER**

ISSUED

THIS DRAWING WAS CREATED ON CAD. DRAWING IS ARCHIVED ON MAGNETIC TAPE FOR ECO CHANGES.

SIZE A	FSCM NO	DWG NO. 00275-0081
SCALE N/A	WT. _____	SHEET 3 OF 6

REVISIONS				
REV	DESCRIPTION	CHG. NO.	APP'D	DATE
B		657178		

THE MAXIMUM ALLOWABLE CONNECTED INDUCTANCE (L_a) OF THE ASSOCIATED APPARATUS IS DETERMINED BY ADDING 32 mA TO THE I_{sc} OF THE BARRIER ($I_m = I_{sc} + 32mA$) AND ENTERING TABLE 1 (SHT 5) AT THE RESULTING VALUE, I_m , OR THE NEXT HIGHER VALUE OF I_m , TO DETERMINE THE L_a .

EXAMPLE #1: I_{sc} OF BARRIER = 100mA. (GROUP A)
 $I_m = 100mA + 32mA = 132mA$
 ENTER TABLE AT $I_m = 140mA$; $L_a = 1.60mH$

--WARNING-- BEFORE CONNECTING THE MODEL 275 INTO THE LOOP, DETERMINE THE CONNECTED INDUCTANCE OF THE SYSTEM BY ADDING THE L_1 OF THE TRANSMITTER AND CABLE. THE SUM MUST BE LESS THAN THE L_a DETERMINED FROM THE TABLE IN ORDER FOR THE MODEL 275 TO BE CONNECTED INTO THE LOOP. IF THE CONNECTED INDUCTANCE IS GREATER THAN THE VALUE DETERMINED FROM THE TABLE, A BARRIER WITH A LOWER I_{sc} MUST BE CHOSEN.

EXAMPLE #2: BARRIER I_{sc} = 41.8mA; BARRIER L_a = 20.0mH
 $I_m = 41.8mA + 32mA = 73.8mA$;
 ENTER TABLE AT 80mA AND READ $L_a = 6.0mH$
 ADD CONNECTED INDUCTANCE OF SYSTEM:

MODEL 3051 TRANSMITTER	$L_1 = 0.48mH$
INDUCTANCE OF LOOP WIRING	1.0mH

TOTAL CONNECTED INDUCTANCE	= 1.48mH

TOTAL CONNECTED INDUCTANCE IS LESS THAN $L_a = 6.0$ mH AS DETERMINED ABOVE AND IS ALSO LESS THAN THE BARRIER L_a . THE MODEL 275 MAY SAFELY BE CONNECTED INTO THE LOOP. IF THE MODEL 751 INDICATORS ARE USED, THEIR TOTAL INDUCTANCE (LABEL VALUE * NUMBER OF INDICATORS) MUST ALSO BE INCLUDED.

Rosemount Inc. 12001 Technology Drive Eden Prairie, MN 55344 USA	THIS DRAWING WAS CREATED ON CAD. DRAWING IS ARCHIVED ON MAGNETIC TAPE FOR ECO CHANGES.		
DR. C.SCRIBNER 6/2/93	SIZE A	FSCM NO	DWG NO. 00275-0081
ISSUED	SCALE N/A	WT. _____	SHEET 4 OF 6

REVISIONS				
REV	DESCRIPTION	CHG. NO.	APP'D	DATE
B		657178		

Im (mA)	La (mH)		
	GROUPS A & B	GROUP C	GROUP D
300	0.20	1.80	3.20
280	0.21	2.00	3.70
270	0.23	2.20	3.90
260	0.25	2.50	4.30
250	0.27	2.70	4.60
240	0.30	3.00	5.00
220	0.40	3.20	5.90
200	0.50	4.00	7.20
180	0.60	5.00	8.80
170	0.80	5.50	9.90
160	1.00	6.20	11.20
150	1.30	7.00	12.70
140	1.60	8.00	14.60
130	2.00	9.00	16.90
120	2.50	10.00	19.80
110	3.00	12.00	23.60
100	4.00	15.00	28.50
90	5.00	18.00	35.10
85	5.50	20.00	39.30
80	6.00	22.00	44.40
75	6.70	25.00	50.50
70	7.50	28.00	57.90
65	8.80	34.00	67.10
62	9.50	37.00	73.70
60	10.00	40.00	78.70
57	11.00	43.00	87.10
55	12.00	48.00	93.50
50	15.00	56.00	113.10
45	19.00	70.00	139.40
40	23.00	87.00	176.30
35	31.00	110.00	229.90
32	36.00	135.00	274.80
30	40.00	150.00	312.40
28	46.00	170.00	358.40
25	58.00	210.00	449.00
23	68.00	250.00	530.10
21	82.00	300.00	635.30
20	90.00	330.00	700.00

TABLE 1

Rosemount Inc. 12001 Technology Drive Eden Prairie, MN 55344 USA		THIS DRAWING WAS CREATED ON CAD. DRAWING IS ARCHIVED ON MAGNETIC TAPE FOR ECO CHANGES.			
DR. C. SCRIBNER	6/2/93	SIZE A	FSCM NO	DWG NO.	00275-0081
ISSUED		SCALE N/A	WT. _____	SHEET	5 OF 6

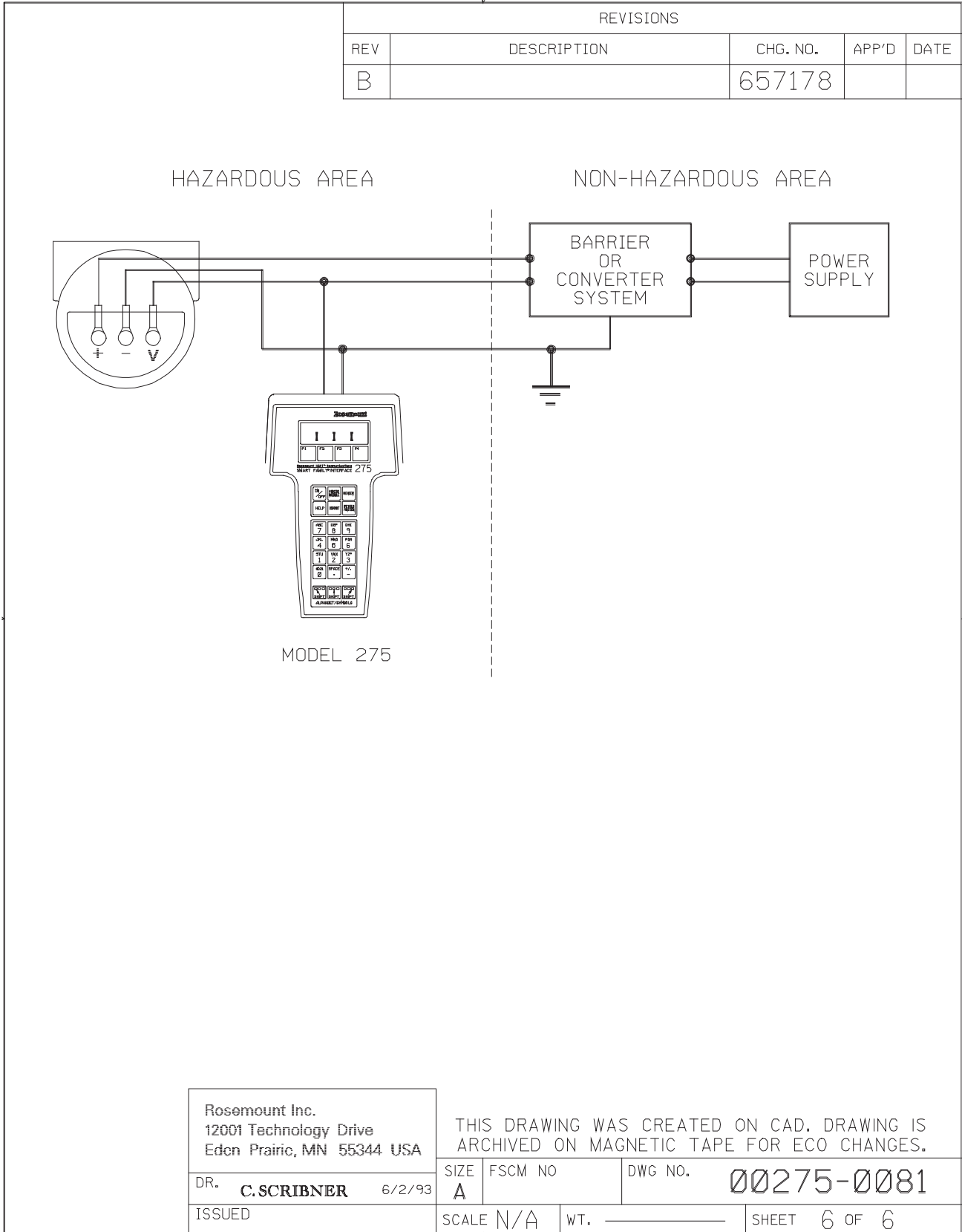
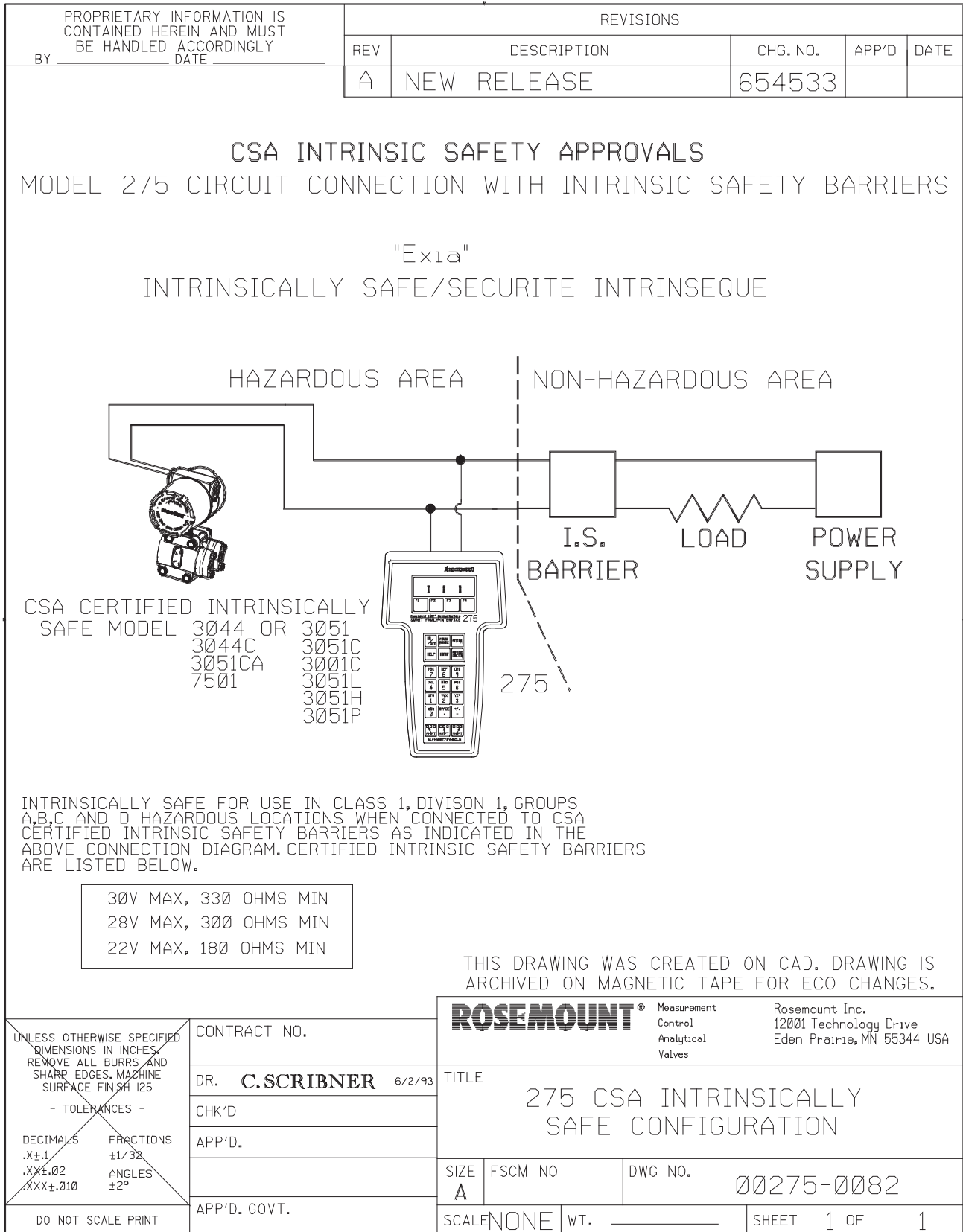
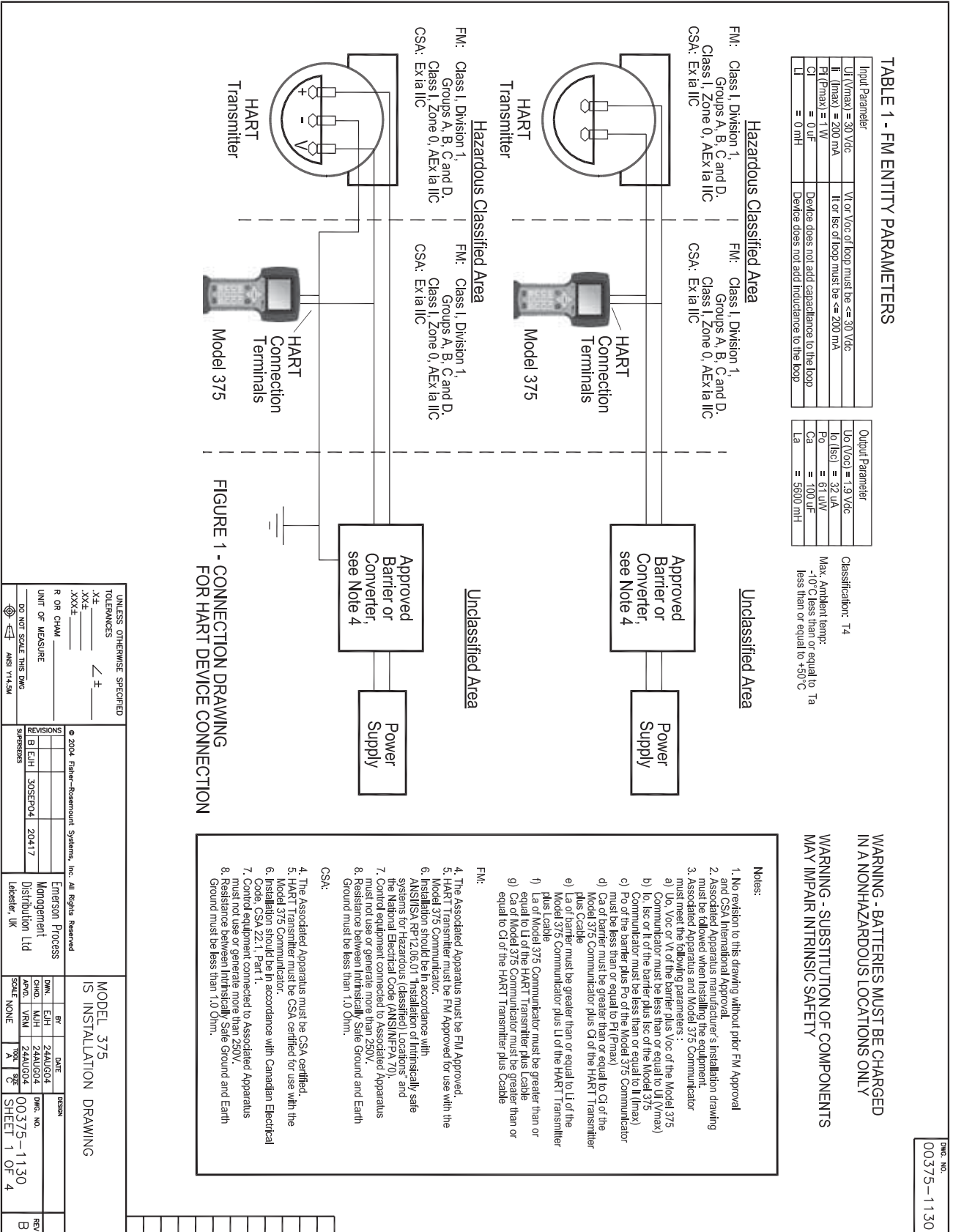

Figure B-5.



Rosemount 1151

Figure B-6.



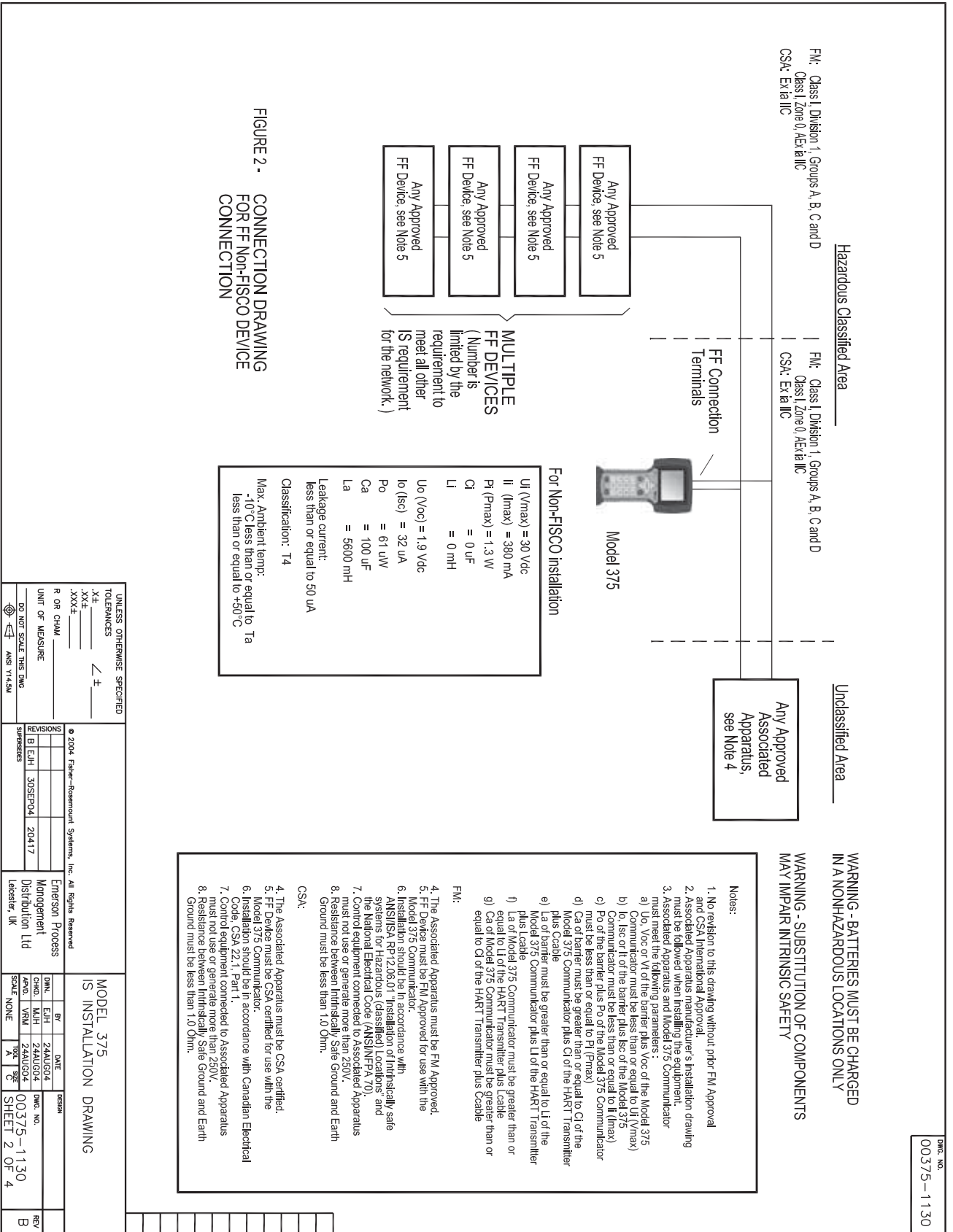

FISCO CONCEPT

THE FISCO CONCEPT ALLOWS INTERCONNECTION OF INTRINSICALLY SAFE APPARATUS TO ASSOCIATED APPARATUS NOT SPECIALLY EXAMINED IN SUCH COMBINATION. THE CRITERIA FOR INTERCONNECTION IS THAT THE VOLTAGE (U_0 OR V_{max}), THE CURRENT (I_0 OR I_{max}) AND THE POWER (P_0 OR P_{max}) WHICH AN INTRINSICALLY SAFE APPARATUS CAN RECEIVE AND REMAIN INTRINSICALLY SAFE CONSIDERING FAULTS, MUST BE EQUAL OR GREATER THAN VOLTAGE (U_0 , V_{oc} OR V_f), THE CURRENT (I_0 , I_{sc} OR I_f) AND THE POWER (P_0 OR P_{max}) LEVELS WHICH CAN BE DELIVERED BY THE ASSOCIATED APPARATUS, CONSIDERING FAULTS AND APPLICABLE FACTORS. IN ADDITION, THE MAXIMUM UNPROTECTED CAPACITANCE (C) AND THE INDUCTANCE (L) OF EACH APPARATUS (OTHER THAN THE TERMINATION) CONNECTED TO THE FIELDBUS MUST BE LESS THAN OR EQUAL TO 5 nF and 10 uH RESPECTIVELY.

IN EACH SEGMENT ONLY ONE ACTIVE DEVICE, NORMALLY THE ASSOCIATED APPARATUS, IS ALLOWED TO PROVIDE THE NECESSARY ENERGY FOR THE FIELDBUS SYSTEM. THE VOLTAGE U_0 (OR V_{oc} OR V_f) OF THE ASSOCIATED APPARATUS IS LIMITED TO A RANGE OF 14 V TO 24 Vdc. ALL OTHER EQUIPMENT CONNECTED TO THE BUS CABLE HAS TO BE PASSIVE. MEANING THAT THEY ARE NOT ALLOWED TO PROVIDE ENERGY TO THE SYSTEM, EXCEPT A LEAKAGE CURRENT OF 50uA FOR EACH CONNECTED DEVICE. SEPARATELY POWERED EQUIPMENT NEEDS GALVANIC ISOLATION TO ASSURE THAT THE INTRINSICALLY SAFE FIELDBUS CIRCUIT REMAINS PASSIVE.

THE CABLE USED TO INTERCONNECT DEVICES NEEDS TO HAVE THE PARAMETERS IN THE FOLLOWING RANGE:

- Loop Resistance R: 15.....150 Ohm/km
- Inductance per unit length L: 0.4.....1 mH/km
- Capacitance per unit length C: 80.....200 nF
- C = C line/line + 0.5C line/screen, if both lines are floating, or
- C = C line/line + C line/screen, if the screen is connected to one line
- Length of trunk cable: less than or equal to 1000m
- Length of spur cable: less than or equal to 30m
- Length of spur splice: less than or equal to 1m

AT EACH END OF THE TRUNK CABLE AN APPROVED INFALLIBLE LINE TERMINATION WITH THE FOLLOWING PARAMETERS IS SUITABLE:

- R = 90.....100 Ohm
- C = 0.....2.2 uF

ONE OF THE ALLOWED TERMINATIONS MIGHT ALREADY BE INTEGRATED IN THE ASSOCIATED APPARATUS. THE NUMBER OF PASSIVE APPARATUS CONNECTED TO THE BUS SEGMENT IS NOT LIMITED DUE TO I.S. REASONS. IF THE ABOVE RULES ARE RESPECTED, UP TO A TOTAL LENGTH OF 1000 m (SUM OF TRUNK AND ALL SPUR CABLES) OF CABLE IS PERMITTED. THE INDUCTANCE AND THE CAPACITANCE OF THE CABLE WILL NOT IMPAIR THE INTRINSIC SAFETY OF THE INSTALLATION.

DRG. NO.
00375-1130

UNLESS OTHERWISE SPECIFIED TOLERANCES		X ±		XXX ±		R OR CHAIN		UNIT OF MEASURE		DO NOT SCALE THIS DWG		ANSI 11.4/ASME	
EMERSON PROCESS MANAGEMENT DISTRIBUTION LTD		LEICESTER, UK		© 2004 Fisher-Rosemount Systems, Inc. All Rights Reserved		REVISIONS		DATE		BY		DESIGN	
MODEL 375 IS INSTALLATION DRAWING		DWN. E.J.H		24AUG04		CHKD. M.J.H		24AUG04		DWC. NO.		00375-1130	
REV B		APPR. V.R.M		NONE		SCALE NONE		NONE		SHEET 4 OF 4		REV B	

Appendix C Glossary

Some of the terms used in this manual relate specifically to the operation of Rosemount transmitters, hand-held communicators, and other Rosemount products. The following list provides brief definitions. See the sections listed for additional information.

Analog Output Trim	Digital trim operation that allows adjustment of the output electronics to conform to the plant standard of current. Three types of analog output trim are available: 4–20 mA output trim, 4–20 mA other scale, and low power.
Cloning	Off-line operation that uses a HART-based communicator to copy configuration data from one transmitter to one or more other transmitters that require the same data.
Commissioning	Functions performed with the HART-based communicator and the transmitter that test the transmitter and test the loop, and verify transmitter configuration data.
Configuration	Process of setting parameters that determine how the transmitter operates.
Damping	Output function that increases the response time of the transmitter to smooth the output when there are rapid input variations.
Descriptor	Sixteen-character field for additional identification of the transmitter, its use, or location. The descriptor is stored in the transmitter and can be changed using the HART-based communicator.
Digital Trim	Format function that allows you to adjust the transmitter characterization for purposes of digital calibration to plant standards. Digital trim includes two separate operations: sensor trim and analog output trim.
Failure Mode Alarm	Transmitter function that drives the analog output to a jumper-selectable high or low value in the event of an electronics failure.
Factory Characterization	Factory process during which each sensor module is subjected to pressures and temperatures covering the full operating range. The sensor module memory stores data generated from this process for use by the microprocessor in correcting the transmitter output during operation.
HART (Highway Addressable Remote Transducer) Protocol	Communications standard that provides simultaneous analog and digital signal transmission between control rooms and field devices such as transmitters. All Rosemount SMART FAMILY products communicate using the HART protocol.

Rosemount 1151

Lower Range Limit (LRL)	Lowest value of the measured variable that the transmitter can be configured to measure.
Lower Range Value (LRV)	Lowest value of the measured variable that the analog output of the transmitter is currently configured to measure.
Multidropping	The connection of several transmitters to a single communications transmission line. Communication between the host and the transmitters takes place digitally with the analog output of the transmitters deactivated.
Reranging	Configuration function that changes the transmitter 4 and 20 mA settings.
Send Data	HART-based communicator command that transfers configuration data from the hand-held communicator's memory to the transmitter memory.
Sensor Trim	Sensor trim function in which two accurate, end-point pressures are applied and all output is linearized between them. The selected end points should always be equal to or outside the LRV and URV. This is also known as a Full Trim.
Smart	Term used to describe instruments that are microprocessor-based and feature advanced communications capabilities.
SMART FAMILY	Rosemount pressure, temperature, level, and flow instruments with microprocessor-based digital electronics.
Span	Algebraic difference between the upper and lower range values.
Tag	Eight-character field for identifying the transmitter. The tag is stored in the transmitter and can be changed using the HART Communicator and the transmitter information function.
Transmitter Address	Unique number (1-15) used to identify a multidropped transmitter. Transmitters that are not multidropped have 0 as an address.
Transmitter Security	Jumper-selectable feature that prevents accidental or deliberate changes to configuration data.
Upper Range Limit (URL)	Highest value of the measured variable that the transmitter can be configured to measure.
Upper Range Value (URV)	Highest value of the measured variable that the analog output of the transmitter is currently configured to measure.
Zero Trim	A zero-based, one-point adjustment used in differential pressure applications to compensate for mounting position effects or zero shifts caused by static pressure.

Index

A

- Access Requirements
 - Circuit Side of Electronics Housing 2-5
 - Exterior of Electronics Housing 2-5
 - Process Flange Orientation 2-4
 - Terminal Side of Electronics Housing 2-4
- Adjustment
 - Damping Adjustment . . . 4-15
 - Linearity Adjustment . . . 4-15
- Amplifier Board Standoffs 6-5
- Analog Electronics (Figure 12-1) 6-3
- Analog Electronics Assembly . 6-2

B

- Backup Ring Installation 5-16
- Board Spacers 6-10
- Brackets
 - Mounting Options 2-11
- Bubbler Liquid Level Measurement 2-20
- Bubbler System in Open Vessel 2-20
 - Liquid Level Measurement 2-20

C

- Calibrate the Sensor 3-12
- Calibration
 - Damping Adjustment . . . 4-15
 - Data Flow 4-11
 - Elevated or Suppressed Zeros 4-14
 - Linearity Adjustment . . . 4-15
 - Span Adjustment Range 4-11
 - Static Pressure Span Correction Factor 4-16
 - Zero Adjustment Range . 4-11
 - Zero and Span Adjustment 4-13
- Characterization
 - Before Characterizing the Transmitter . . . 6-13
 - Characterizing with a Model 275 Communicator . 6-14
- Circuit Side of Electronics Housing 2-5
- Closed Vessels
 - Dry Leg Condition 2-18
 - Liquid Level Measurement 2-17
 - Wet Leg Condition 2-18
- Commissioning the 1151 with a HART-Based Communicator . . 3-3
- Commissioning the Transmitter on the Bench 3-1
- Configuration
 - LCD Meter 2-21

- Connecting the Electrical Housing to the Sensor 5-16
- Connections
 - Electrical Housing to the Sensor 5-7
 - Header Board (Figure 9-4) 5-9

D

- Damping Adjustment 4-15
- Data Flow with Calibration Options 4-11
- Digital Trim (Analog Output Trim and Sensor Trim) 4-4
- Disassembly
 - Transmitter Disassembly 5-12
- Drain/Vent Valves 2-8
- Dry Leg Condition
 - Liquid Level Measurement 2-18

E

- Electrical Housing 5-6, 5-7
- Electrical Installation Considerations 2-13
 - Grounding 2-14
 - Power Supply 2-13
 - Signal and Test Terminals 2-14
 - Wiring 2-14
- Elevated or Suppressed Zeros 4-14
- Elevation and Suppression Jumper Settings 4-13
- Environmental Considerations 2-17
- Environmental Requirements
 - Mounting Requirements . . 2-8
- Exterior of Electronics Housing 2-5

F

- Filter Terminal Blocks
 - Installation 2-25

G

- Gas
 - Mounting Requirements . . 2-8
- Grounding 2-14
 - Effects on Accuracy for Fast Sample Computers 2-16
- Transmitter Case 2-15

H

- Hazardous Locations 2-17
- Header Board Connections (Figure 9-4)

Housing

- Electrical 5-6, 5-7
 - Connecting Sensor . . 5-7
 - Sensor Removal . . . 5-6
- Electronic
 - Circuit Side 2-5
 - Exterior 2-5
 - Terminal Side 2-4
- Rotation 2-4

I

- Impulse Piping 2-9
- Installation Diagrams . . . 2-9
- Installation 2-25
 - Board Spacers 6-10
 - Electrical Considerations . 2-13
 - Environmental Considerations . 2-17
 - General Considerations . . 2-4
 - Hazardous Locations . . . 2-17
 - Mounting Bracket Options 2-11
 - Mounting Considerations 2-11
 - Power Supply Load Limitations . . . 2-13
 - Process Considerations . 2-10
 - Signal Wiring Grounding . 2-15
 - Smart Retrofit Kit 6-10
- Installation Diagrams
 - Impulse Piping 2-9
- Integral Span and Zero Buttons 3-9, 3-10
- Introduction 1-1

L

- LCD Meter 2-21
 - Assembly 2-23
 - Configuration 2-21
- Linearity Adjustment 4-15
- Liquid
 - Mounting Requirements . . 2-8
- Liquid Level Measurement
 - Bubbler System in Open Vessel . . . 2-20
 - Closed Vessels 2-17
 - Dry Leg Condition 2-18
 - Open Vessels 2-17
 - Wet Leg Condition 2-18

M

- Maintenance
 - Reassembly Procedure . . 5-7
 - Sensor Module Checkout . 5-9
 - Troubleshooting Symptoms and Corrective Action (Table 9-2) 5-3

<p>Maintenance and Troubleshooting</p> <ul style="list-style-type: none"> Reassembly Procedure . . . 5-15 Return of Material 5-18 Transmitter Disassembly 5-12 <p>Manual</p> <ul style="list-style-type: none"> Use of 1-1 <p>Menu Tree 3-5</p> <p>Meters</p> <ul style="list-style-type: none"> Optional Plug-in Meters . . 5-18 <p>Model 1151 Analog Electronics (Figure 12-1) 6-3</p> <p>Mounting Bracket Options (Figure 4-2) 2-11</p> <p>Mounting Considerations . . . 2-11</p> <p>Mounting Requirements 2-8</p> <ul style="list-style-type: none"> Drain/Vent Valves 2-8 Impulse Piping 2-9 Taps 2-8 <p>O</p> <p>On-line Configuration</p> <ul style="list-style-type: none"> Transmitter Security 3-2 <p>Open Vessels</p> <ul style="list-style-type: none"> Liquid Level Measurement 2-17 <p>Optional Plug-in Meter 5-9</p> <p>Optional Plug-in Meters 5-18</p> <p>Options</p> <ul style="list-style-type: none"> LCD Meter 2-21 <p>O-ring Installation 5-16</p> <p>P</p> <p>Piping</p> <ul style="list-style-type: none"> Impulse Piping 2-9 <p>Power Supply 2-13</p> <ul style="list-style-type: none"> Load Limitations 2-13 <p>Preliminary Precaution 5-15</p> <p>Process Considerations 2-10</p> <p>Process Flange Orientation . . . 2-4</p> <p>Process Sensor Body 5-6, 5-7</p> <p>Process Sensor Body Removal 5-13</p> <ul style="list-style-type: none"> Sensor Module Checkout 5-14 <p>Q</p> <p>Quick Calibration</p> <ul style="list-style-type: none"> Transmitter Data Flow . . . 4-11 <p>R</p> <p>Rangeability A-3</p> <p>Reassembly Procedure 5-7, 5-15</p> <ul style="list-style-type: none"> Backup Ring and O-ring <ul style="list-style-type: none"> Installation 5-16 Connecting the Electrical Housing to the Sensor 5-7, 5-16 Electrical Housing 5-7 Optional Plug-in Meter . . . 5-9 Optional Plug-in Meters . . 5-18 Preliminary Precaution . . 5-15 Process Sensor Body 5-7 	<ul style="list-style-type: none"> Removing Power 6-3 <ul style="list-style-type: none"> Removing the Amplifier Board Standoffs 6-5 Removing the Analog Electronics Assembly 6-2 Removing the Sensor from the Electrical Housing 5-6, 5-14 Reranging the Transmitter <ul style="list-style-type: none"> Using the Integral Span and Zero Buttons 3-9, 3-10 Retrofit Kit 6-10 Retrofitting the Model 1151 Transmitter <ul style="list-style-type: none"> Installing the Board Spacers 6-10 Installing the Smart Retrofit Kit 6-10 Model 1151 Analog Electronics (Figure 12-1) 6-3 Removing Power 6-3 Removing the Analog Electronics Assembly 6-2 <p>Return of Material 5-18</p> <p>Rotating Housing 2-4</p> <p>S</p> <p>Sensor</p> <ul style="list-style-type: none"> Connecting to the Electrical Housing 5-7 Removal from Electrical Housing 5-6 Sensor Body Removal . . . 5-13 Sensor Module Checkout 5-14 Sensor Removal 5-14 <p>Sensor Module Checkout 5-9</p> <ul style="list-style-type: none"> Header Board Connections (Figure 9-4) 5-9 <p>Sensor Trim 4-4</p> <p>Setting Output Units 4-2</p> <p>Setting the Loop to Manual . . . 3-7</p> <p>Signal Terminals 2-14</p> <p>Signal Wiring Grounding . . . 2-15</p> <p>Smart Retrofit Kit 6-10</p> <p>Span Adjustment Range 4-11</p> <p>Specifications and Reference Data</p> <ul style="list-style-type: none"> Model 1151 Transmitter Range Availability A-3 Rangeability (Table 10-1) . . A-3 <p>Startup</p> <ul style="list-style-type: none"> Testing Equipment and Loop 3-6 <p>Static Pressure Span Correction Factor 4-16</p> <p>Steam</p> <ul style="list-style-type: none"> Mounting Requirements . . . 2-8 <p>Suppressed Zeros</p> <ul style="list-style-type: none"> Elevated Zeros 4-14 <p>Systematic Error Correction . . 5-10</p> <p>T</p> <p>Taps 2-8</p>	<p>Terminal Side of Electronics</p> <p>Housing 2-4</p> <p>Terminals 2-14</p> <ul style="list-style-type: none"> Signal 2-14 <p>Test 2-14</p> <p>Test Terminals 2-14</p> <p>Transient Protection</p> <ul style="list-style-type: none"> Installation 2-25 <p>Transmitter</p> <ul style="list-style-type: none"> Data Flow 4-11 Disassembly 5-12 <ul style="list-style-type: none"> Electrical Housing . . . 5-6 Process Sensor Body . . 5-6 Removing the Sensor from the Electrical Housing 5-6 Exploded View 5-13 Range Availability (1151) A-3 Security 3-2 <p>Transmitter Case 2-15</p> <p>Transmitter Disassembly</p> <ul style="list-style-type: none"> Process Sensor <ul style="list-style-type: none"> Body Removal 5-13 Removing the Sensor from the Electrical Housing 5-14 Sensor Module Checkout 5-14 <p>Transmitter Reassembly 5-15</p> <ul style="list-style-type: none"> Backup Ring and O-ring <ul style="list-style-type: none"> Installation 5-16 Connecting the Electrical Housing to the Sensor . . . 5-16 Optional Plug-in Meters . . 5-18 Preliminary Precaution . . 5-15 <p>Troubleshooting Symptoms and Corrective Action (Table 9-2) . . 5-3</p> <p>V</p> <p>Vent/Drain Valves 2-8</p> <p>Vessels</p> <ul style="list-style-type: none"> Open/Closed 2-17 <p>W</p> <p>Wet Leg Condition</p> <ul style="list-style-type: none"> Example (Figure 4-6) . . . 2-19 Liquid Level Measurement 2-18 <p>Wiring 2-14</p> <ul style="list-style-type: none"> Signal Terminals 2-14 Test Terminals 2-14 <p>Z</p> <p>Zero Adjustment Range 4-11</p> <ul style="list-style-type: none"> Elevation and Suppression Jumper Settings 4-13 <p>Zero and Integral Span</p> <ul style="list-style-type: none"> Buttons 3-9, 3-10 Zero and Span Adjustment . . 4-13
--	---	--

Reference Manual

00809-0100-4360, Rev BA
August 2008

Rosemount 1151

Standard Terms and Conditions of Sale can be found at www.rosemount.com/terms_of_sale
The Emerson logo is a trademark and service mark of Emerson Electric Co.
Rosemount, Annubar, ProPlate, and the Rosemount logotype are registered trademarks of Rosemount Inc.
HART is a registered trademark of the HART Communication Foundation. δ -Cell is a trademark of Rosemount Inc.
Fluorolube is a registered trademark of Hooker Chemical Co.
Viton is a registered trademark of E.I. du Pont de Nemours & Co.
Neobee M-20 is a registered trademark of Stepan Chemical Co.
Syltherm and D.C. are registered trademarks of Dow Corning Corp.
Aflas is a registered trademark of Asahi Glass Co., Ltd.
Kynar is a trademark of Pennwalt Inc.
Loctite is a registered trademark of Loctite Corporation.

All other marks are the property of their respective owners.

Emerson Process Management

Rosemount Inc.

8200 Market Boulevard
Chanhassen, MN 55317 USA
T (U.S.) 1 800 999 9307
T (International) (952) 906 8888
F (952) 949 7001
www.rosemount.com

**Emerson Process Management
GmbH & Co.**

Argelsrieder Feld 3
82234 Wessling
Germany
Tel 49 (8153) 9390
Fax 49 (8153) 939172

**Emerson Process Management Asia
Pacific Private Limited**

1 Pandan Crescent
Singapore 128461
T (65) 6777 8211
F (65) 6777 0947
Enquiries@AP.EmersonProcess.com

**Beijing Rosemount Far East
Instrument Co., Limited**

No. 6 North Street,
Hepingli, Dong Cheng District
Beijing 100013, China
T (86) (10) 6428 2233
F (86) (10) 6422 8586

